

PREHISTORIC ORIGAMI

Dinosaurs and Other Creatures

John Montroll

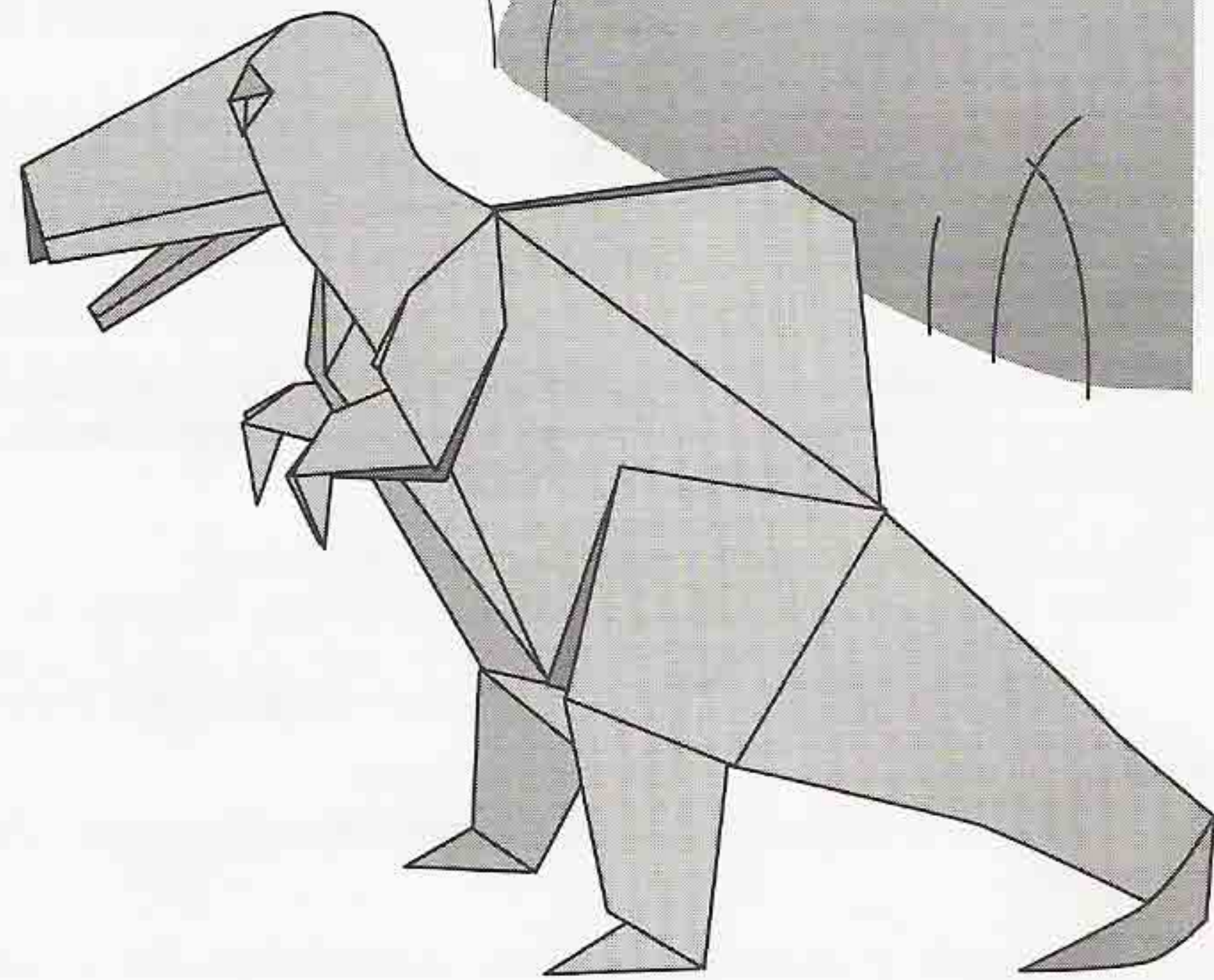
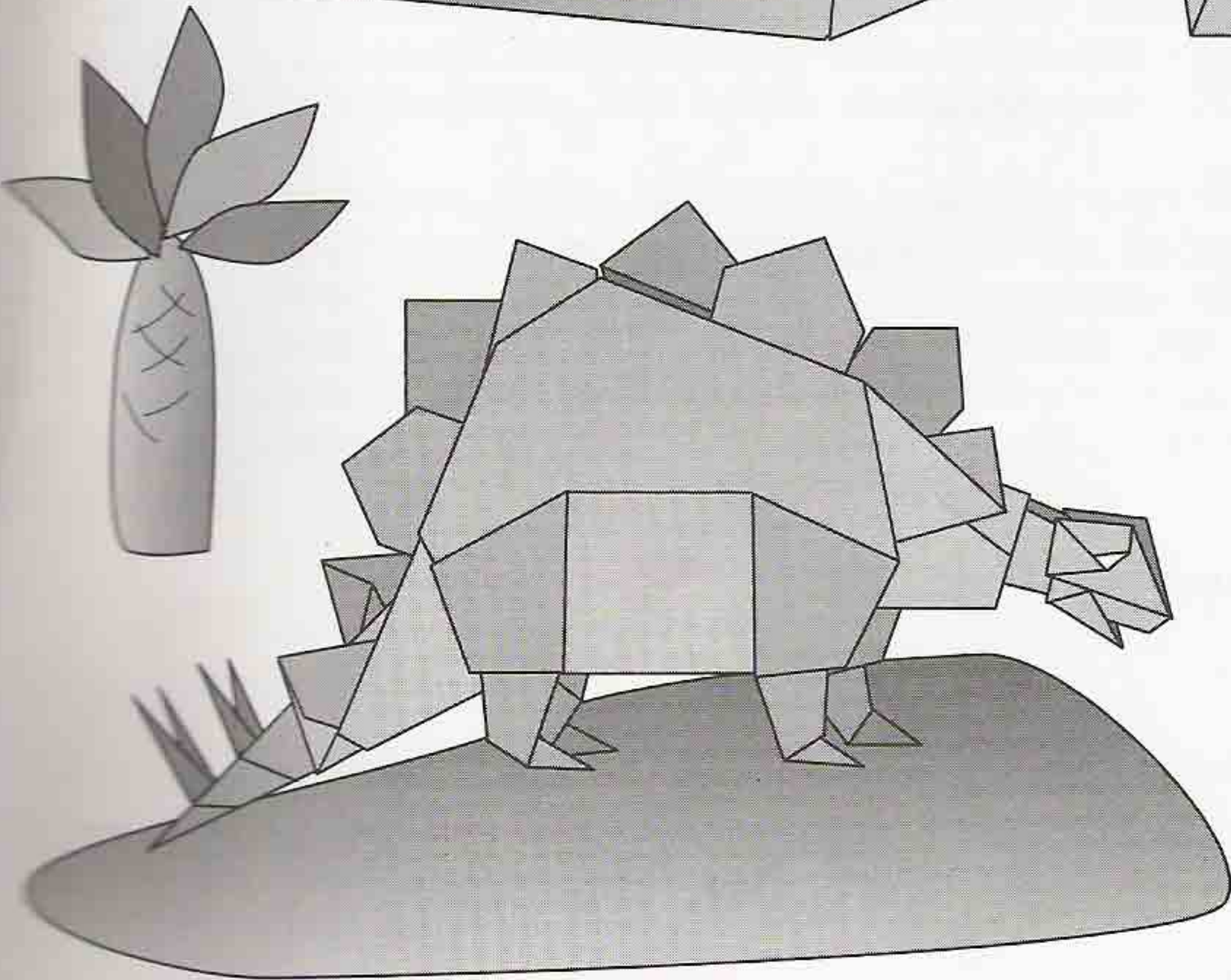
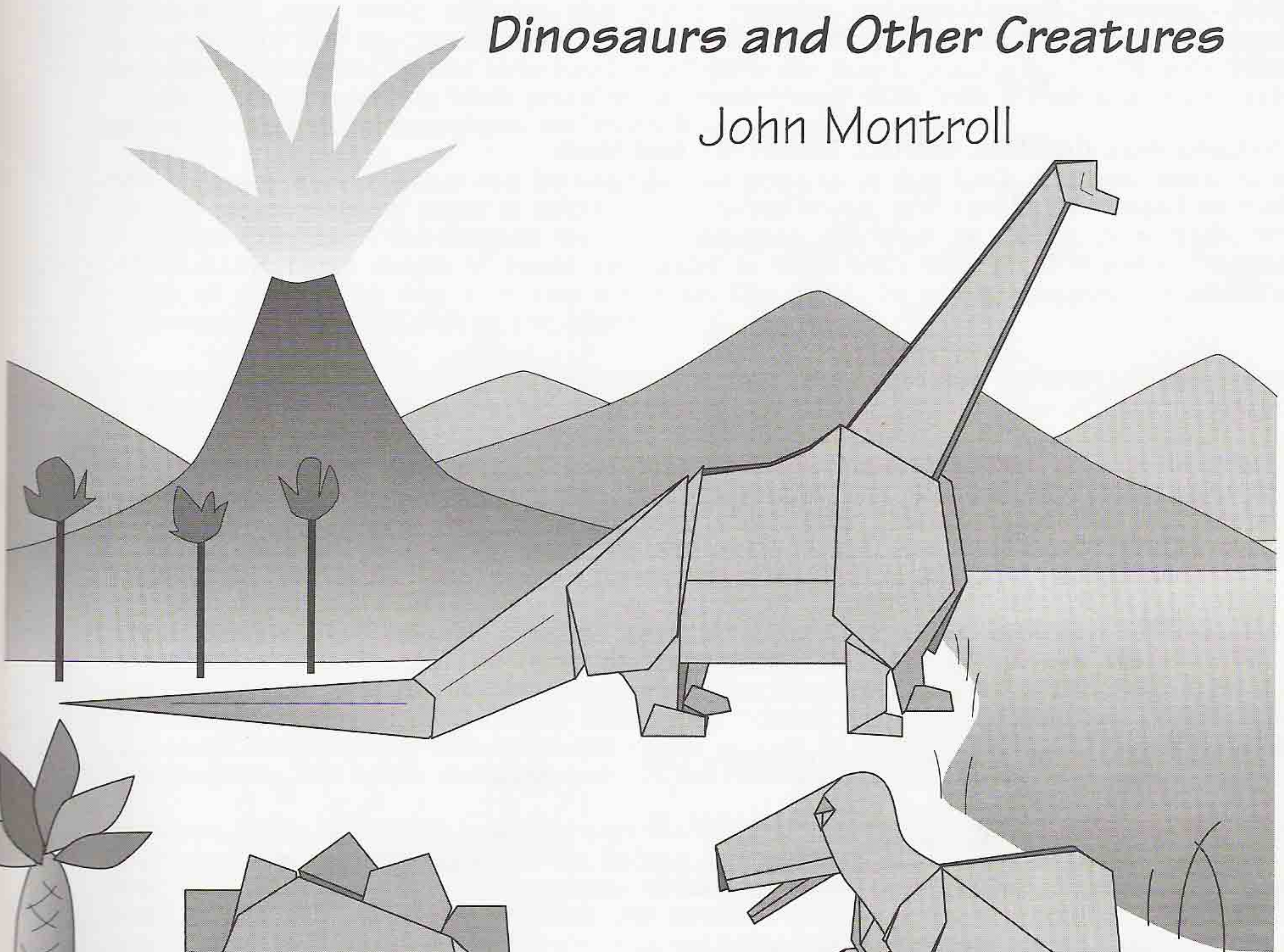

736.982

Paso Robles
Public Library
Paso Robles, California

e.1

Dover Publications, Inc.
New York

Introduction

My goal with this collection of original projects has been to use origami to create an accurate and aesthetically pleasing collection of prehistoric animals. The presentation of animals in this book reflects the most current paleontological theories, from nomenclature (the Apatosaurus has replaced the recently decanonized Brontosaurus from my paper menagerie) to fine structural detail (note the dorsal plating on the Stegosaurus). I hope that the resulting work provides the reader/user with both a technically accurate survey of these extinct creatures and many hours of artistic pleasure.

Although any square paper can be used for the projects in this book, the best material is origami paper. Origami paper is sold in many hobby shops, and can be purchased by mail from The Friends of the Origami Center of America, 15 West 77 Street, New York, NY 10024-5192. Large sheets of paper are easier to work with than smaller ones. Origami paper is colored on one side and white on the other. In my diagrams, the shading represents the colored side of the paper.

Origami paper, and a catalog of other available craft books, can also be ordered from Dover Publications, Inc., 31 East 2nd St., Mineola, NY 11501.

This book is a combination of the old and modern. The ancient art here is illustrated step-by-step with graphics produced on a computer. The illustrations conform to the internationally accepted Randlett-Yoshizawa conventions. The directions for each project have been submitted to experienced origami artists, and I thank the many friends whose suggestions have helped me improve the clarity of my illustrations and explanations.

Other friends have helped in other ways. Martha Landy has provided an excellent introduction and background notes on the animals. Ms. Landy teaches students with special needs in New Brunswick, New Jersey. Her class has produced "Dinosaur Day" for the past eight years at John Adams Elementary School. Her students research and explain dinosaurs and celebrate them with the entire school. In addition to her personal passion for dinosaurs, Ms. Landy finds them one of the most motivating educational tools.

Rosalind Joyce has made valuable contributions to this book through her research and suggestions on the techniques of wet folding. Her methods enable origami artists to infuse their work with more three-dimensional detail than most of us had thought possible. Don Shall helped with computer graphics. My brother Andy helped throughout this project. I give thanks to these talented people, without whose help this book could not have been completed.

John Montroll

Contents

- * Simple
- ** Intermediate
- *** Complex
- **** Very Complex

To Define a Dinosaur	8
Wet Folding	9
Symbols	10
Bird Base	18
Frog Base	47
Basic Folds	118

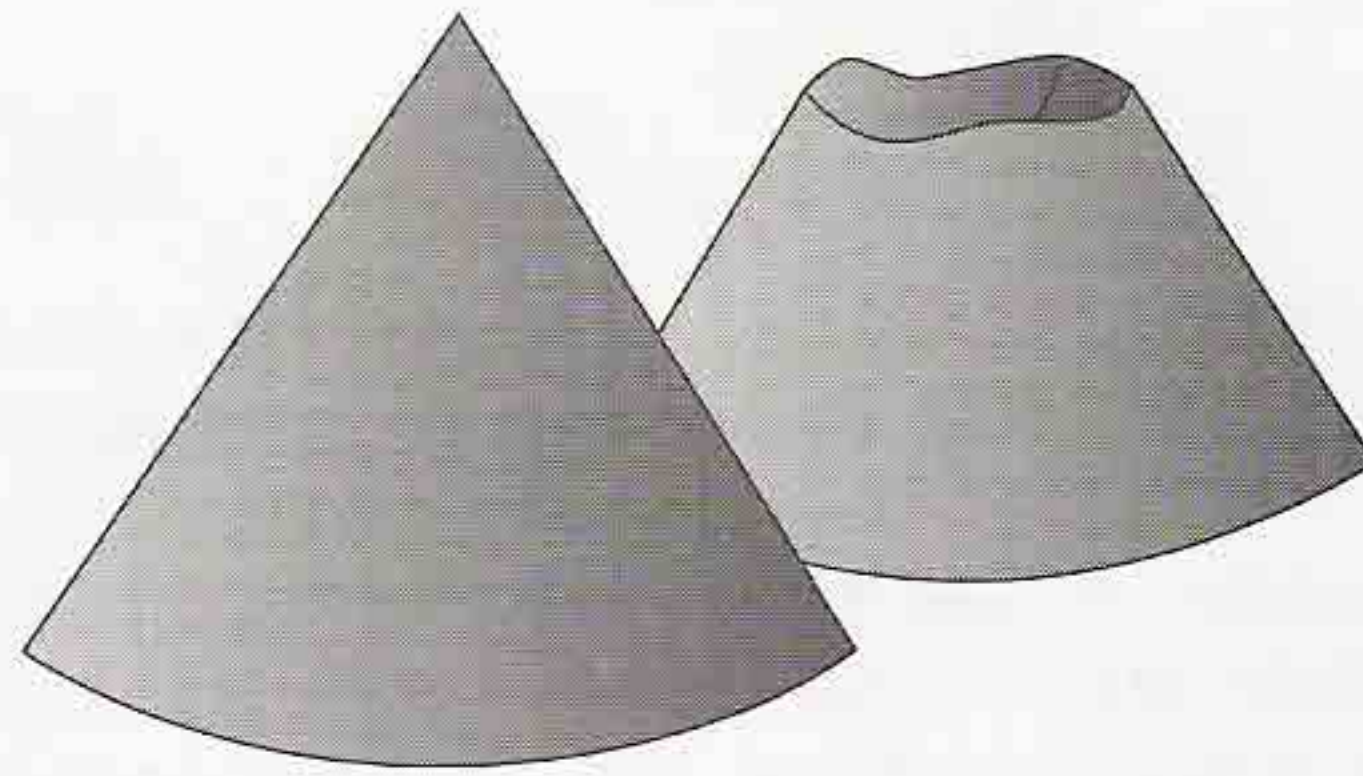

Mountain & Volcano
*
Page 12

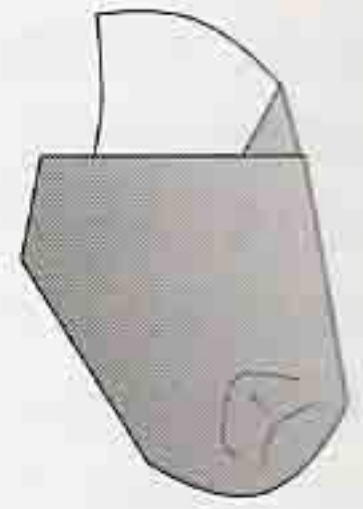

Cracked Dinosaur Egg
*
Page 14

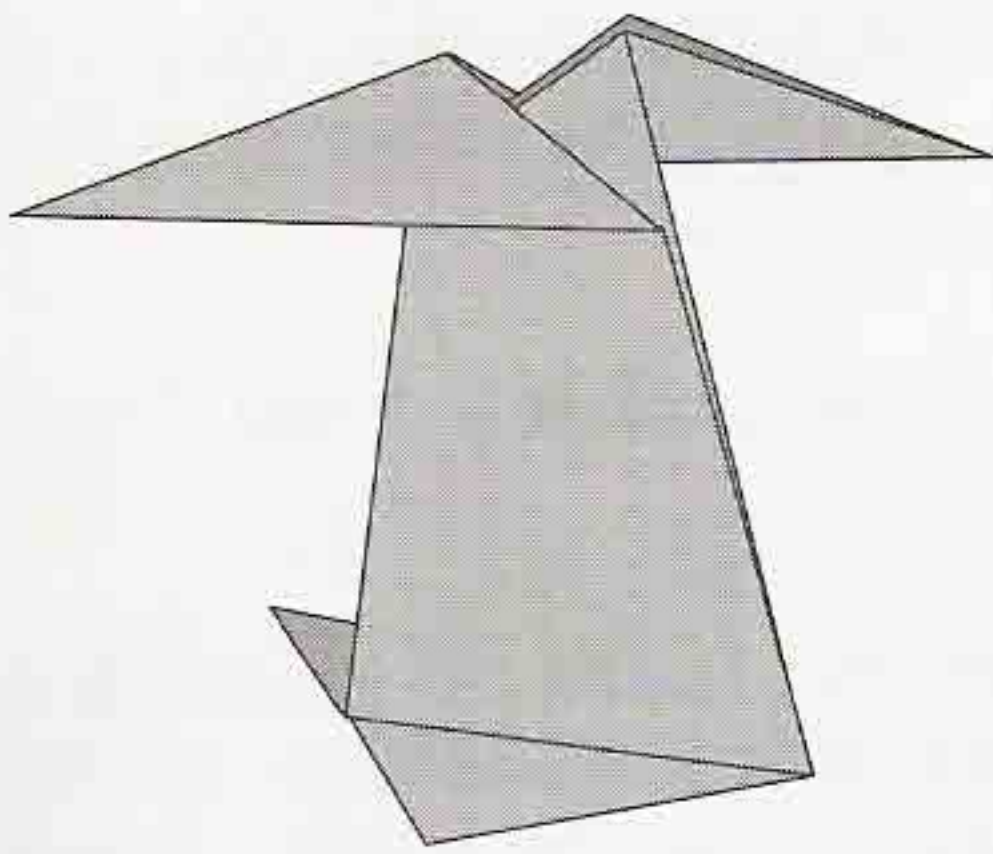

Prehistoric Tree
*
Page 16

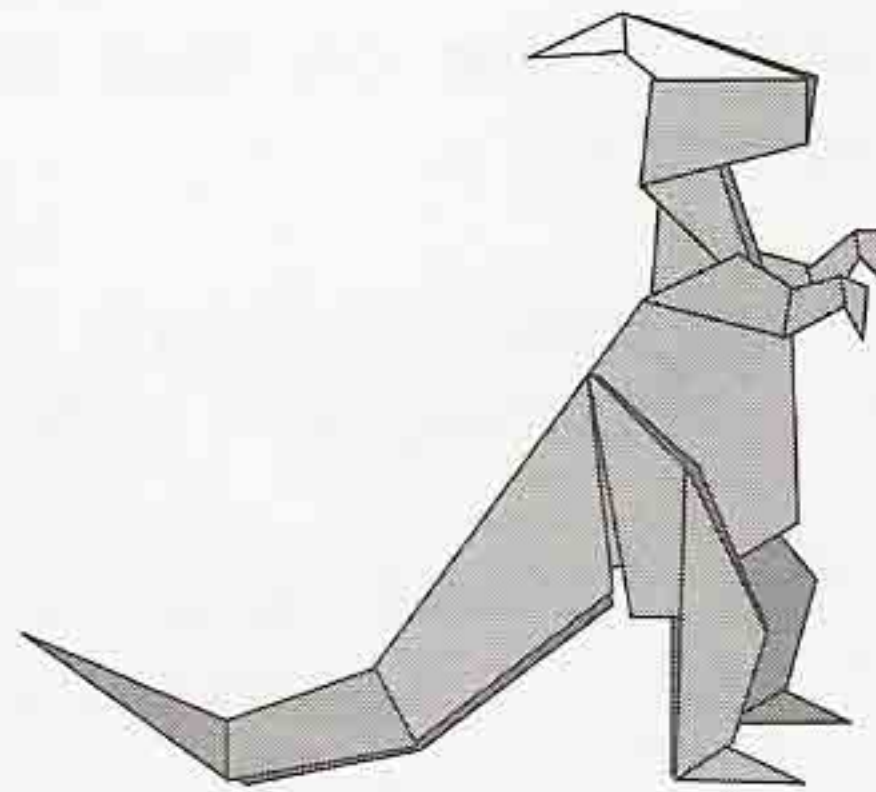

Parasaurolophus
**
Page 20

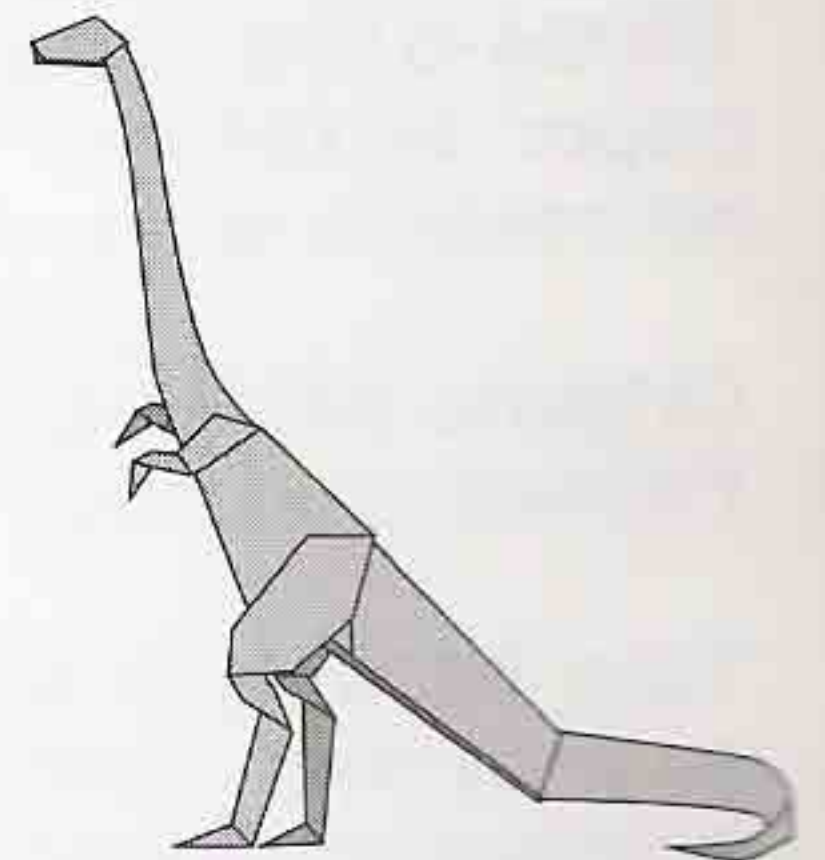

Struthiomimus
**
Page 25

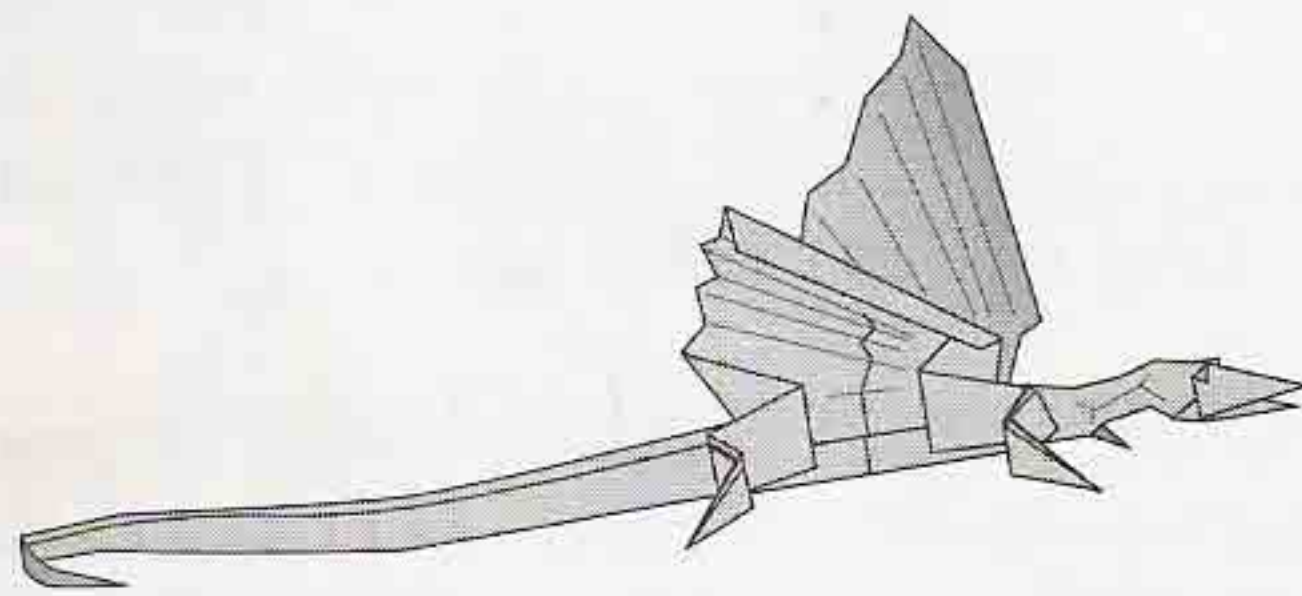

Kuehneosaurus
**
Page 29

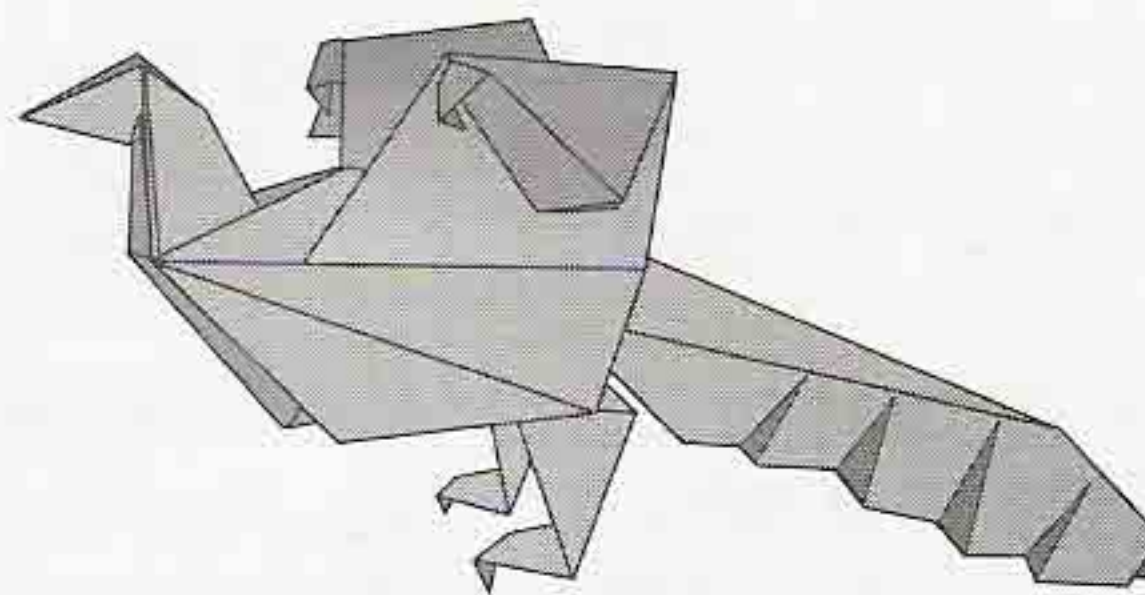

Archaeopteryx
**
Page 33

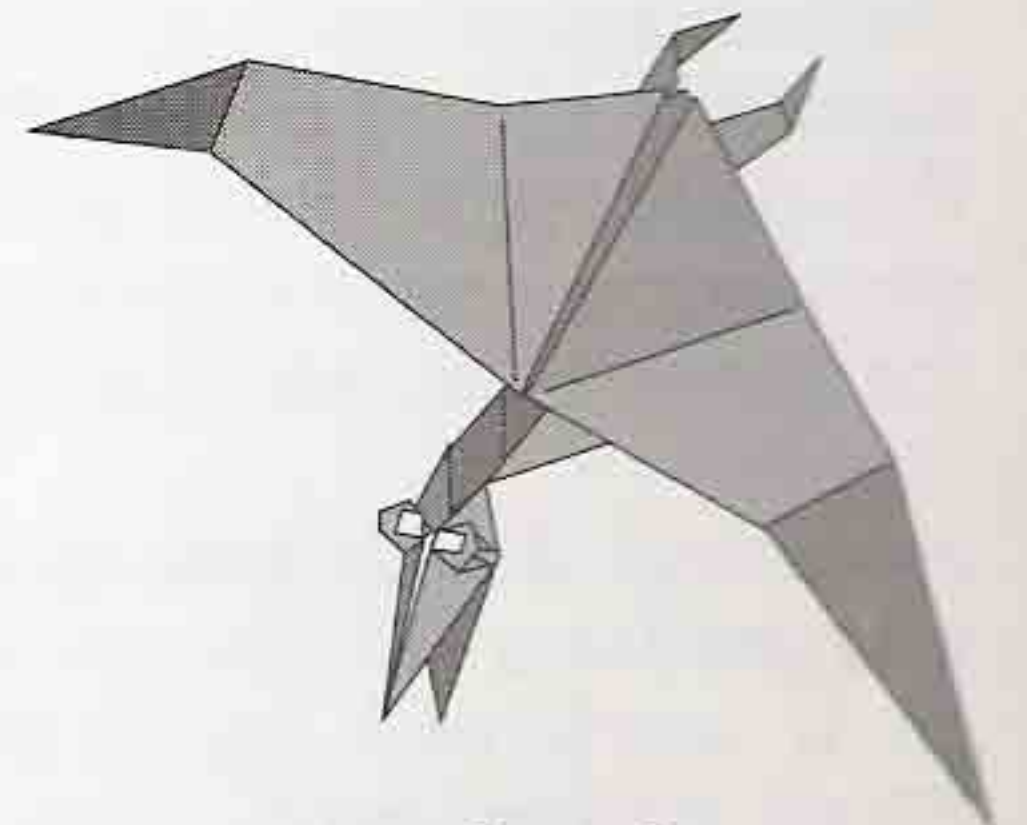

Pterodactylus
**
Page 38

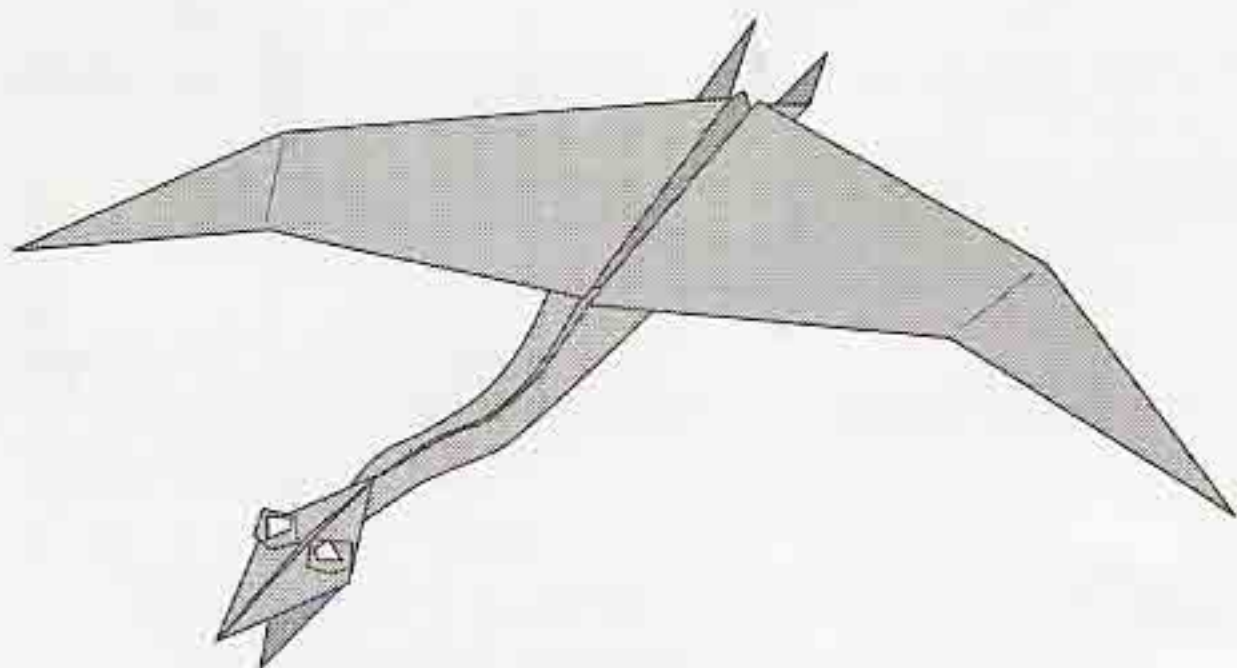

Quetzalcoatlus
**
Page 43

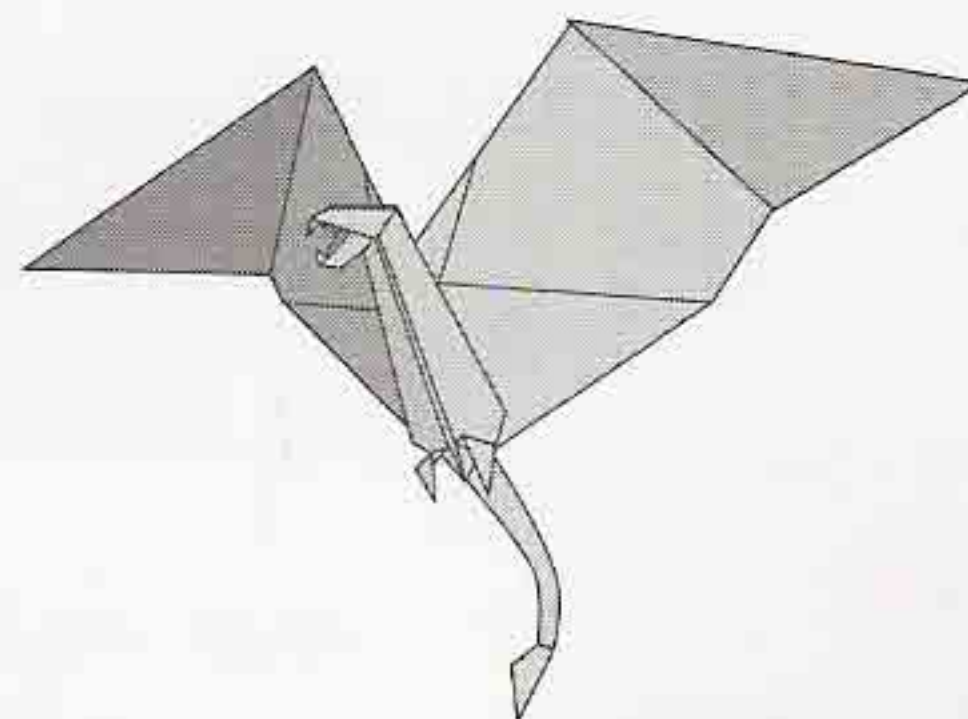

Rhamphorhynchus
**
Page 49

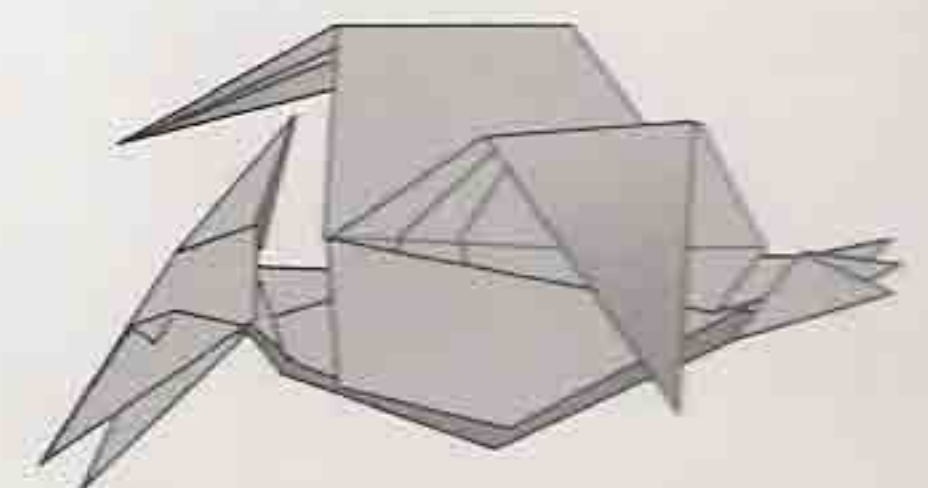

Pteranodon

Page 54

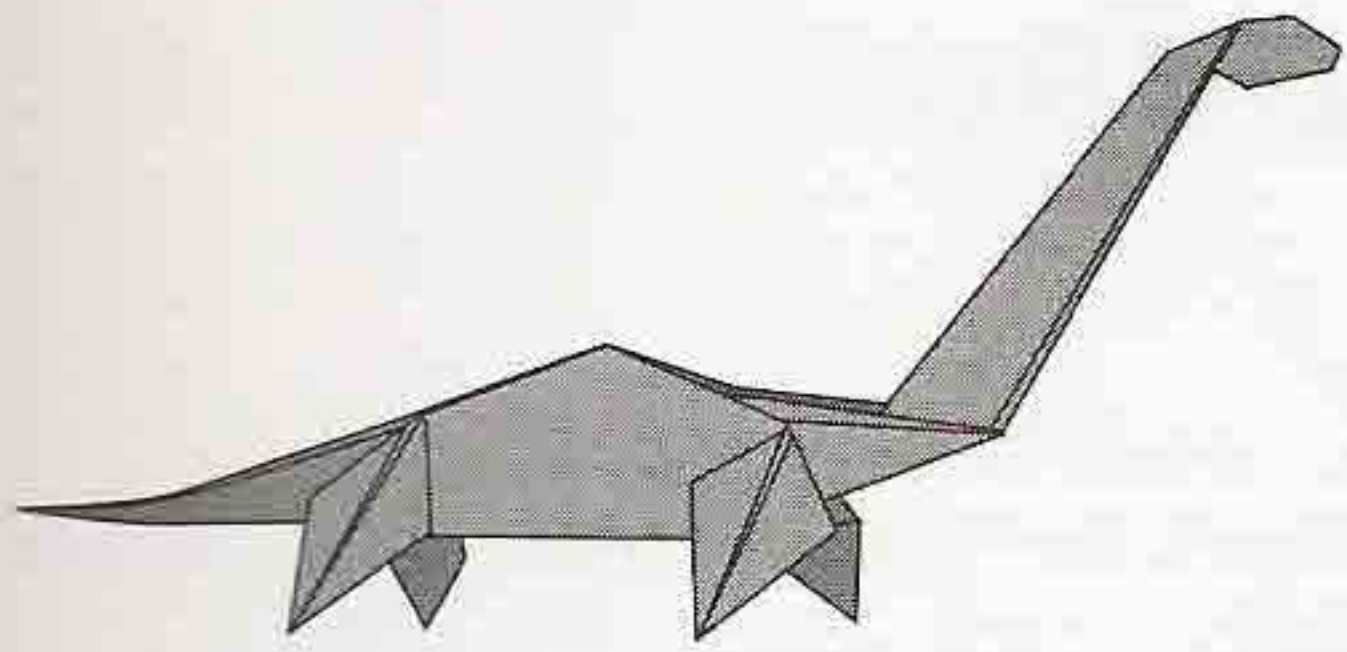

Elasmosaurus
**
Page 58

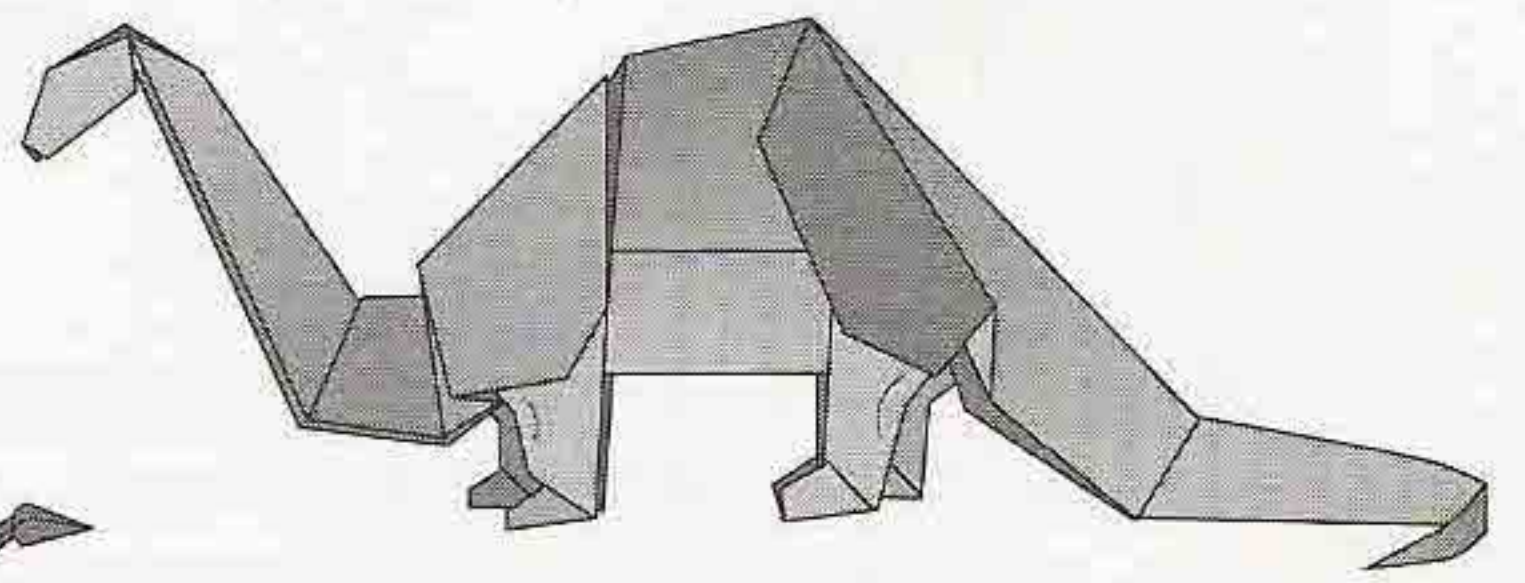

Apatosaurus

Page 64

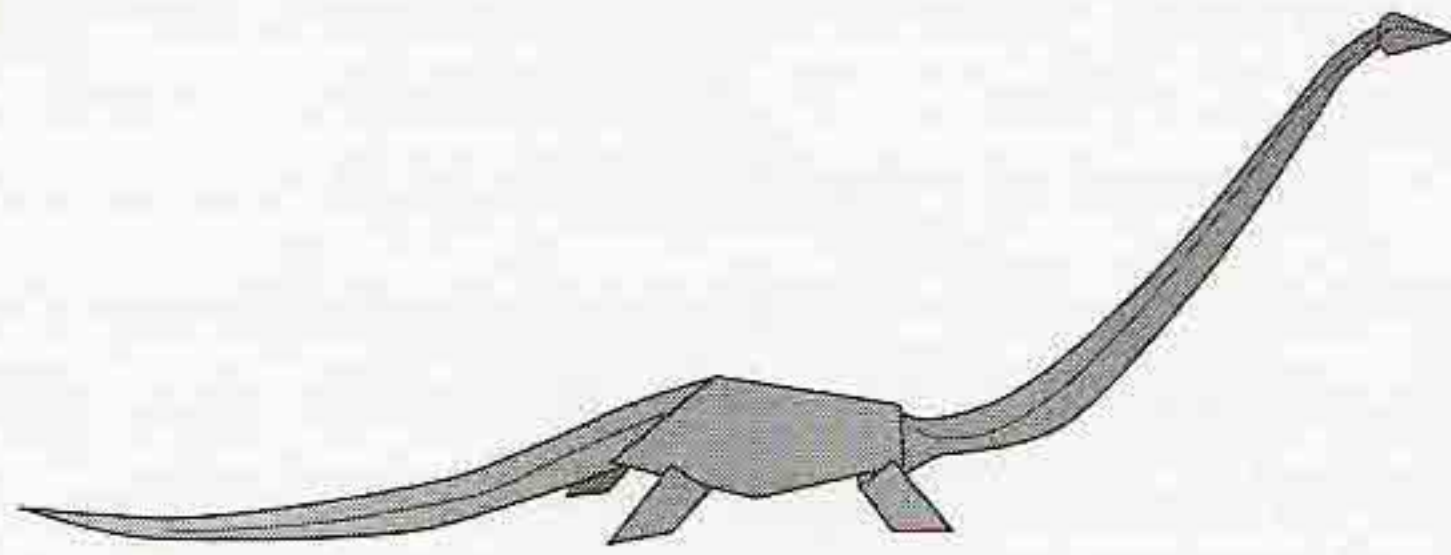

Tanystropheus
**
Page 61

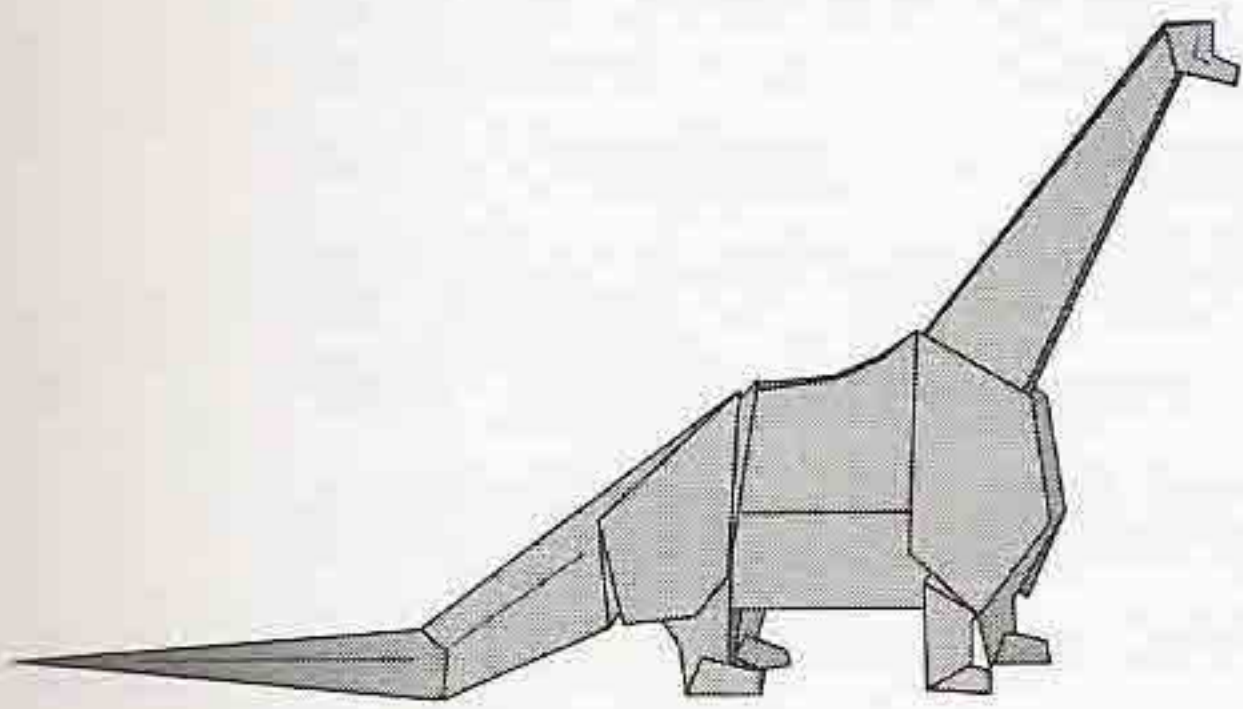

Brachiosaurus

Page 68

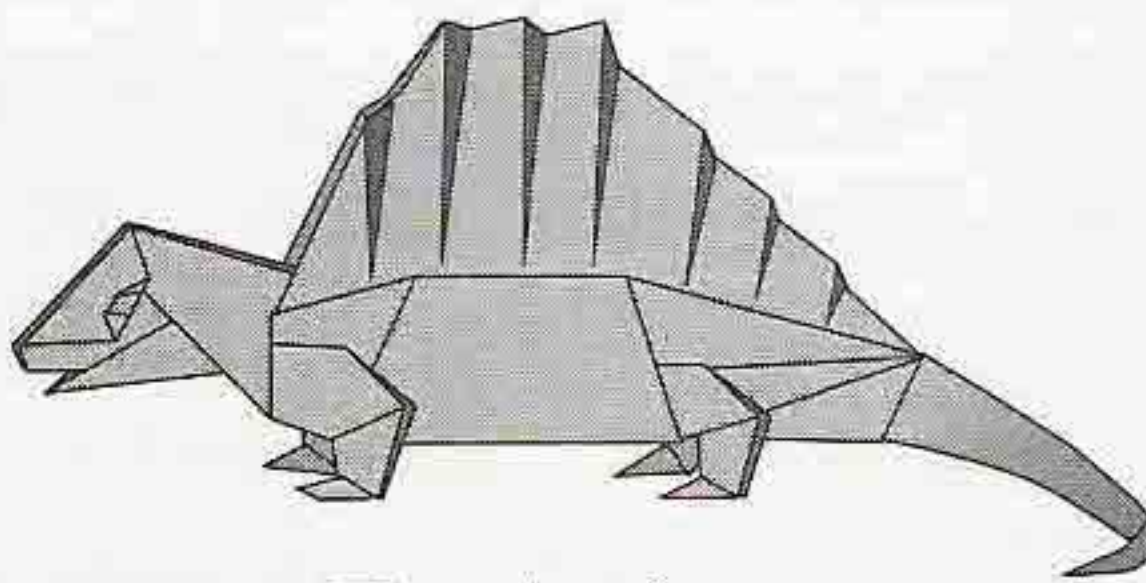

Dimetrodon

Page 71

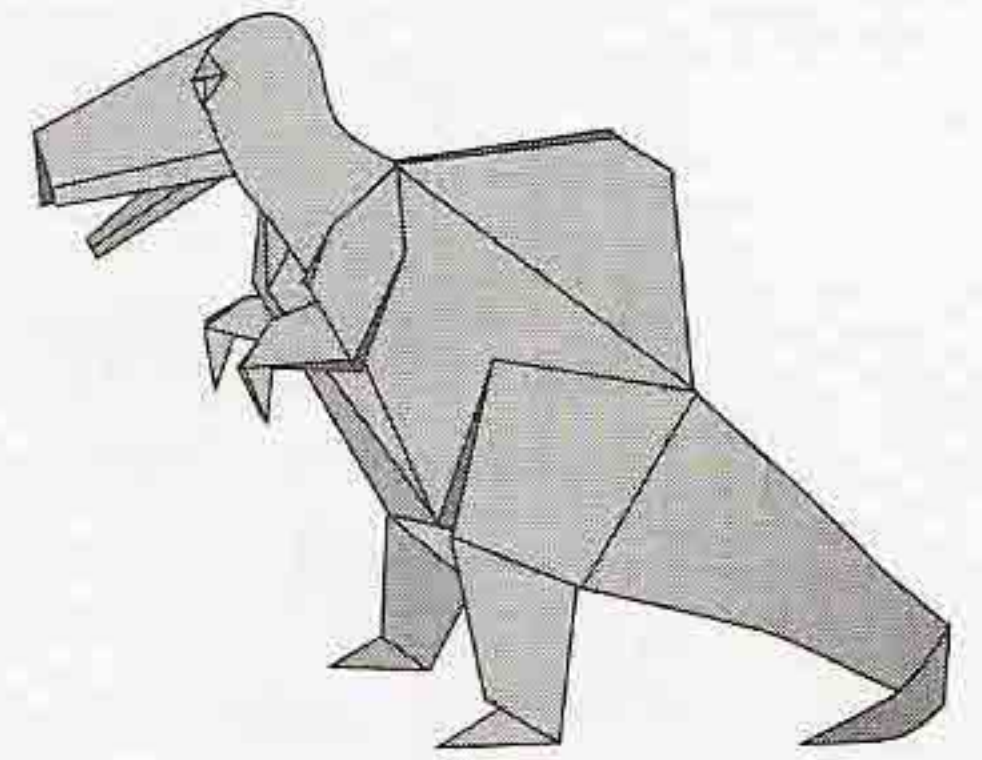

Spinosaurus

Page 74

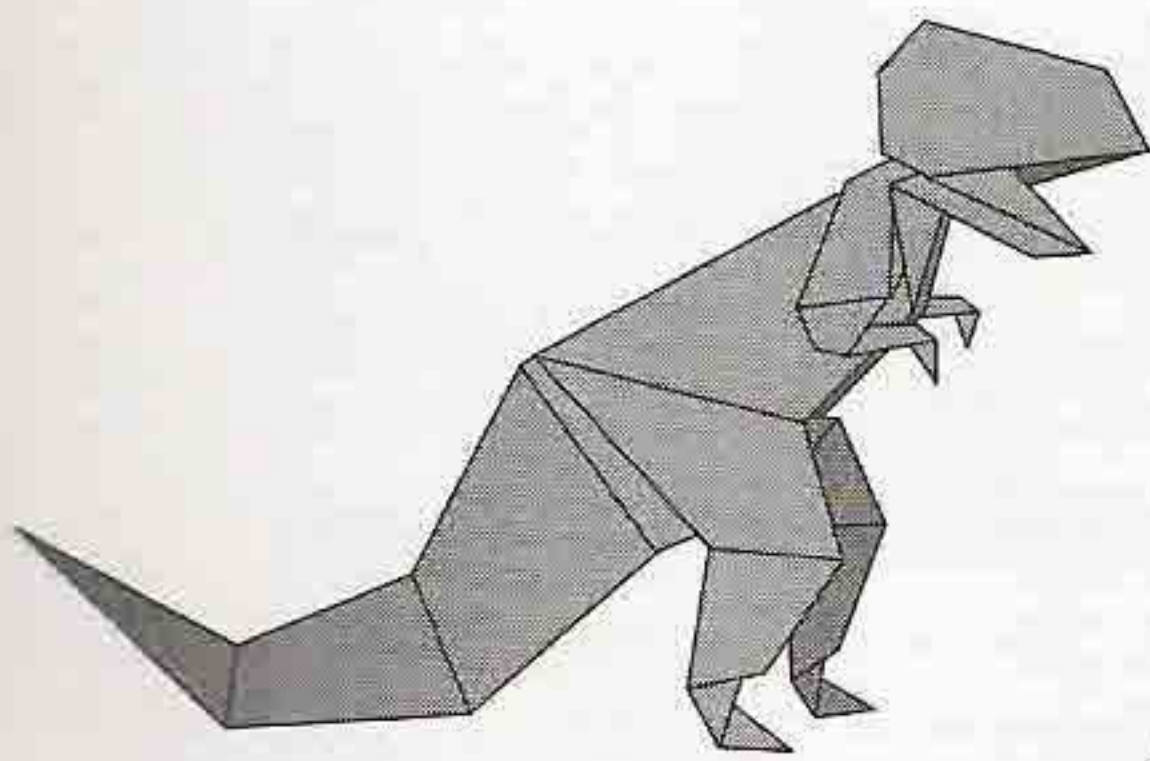

Tyrannosaurus

Page 79

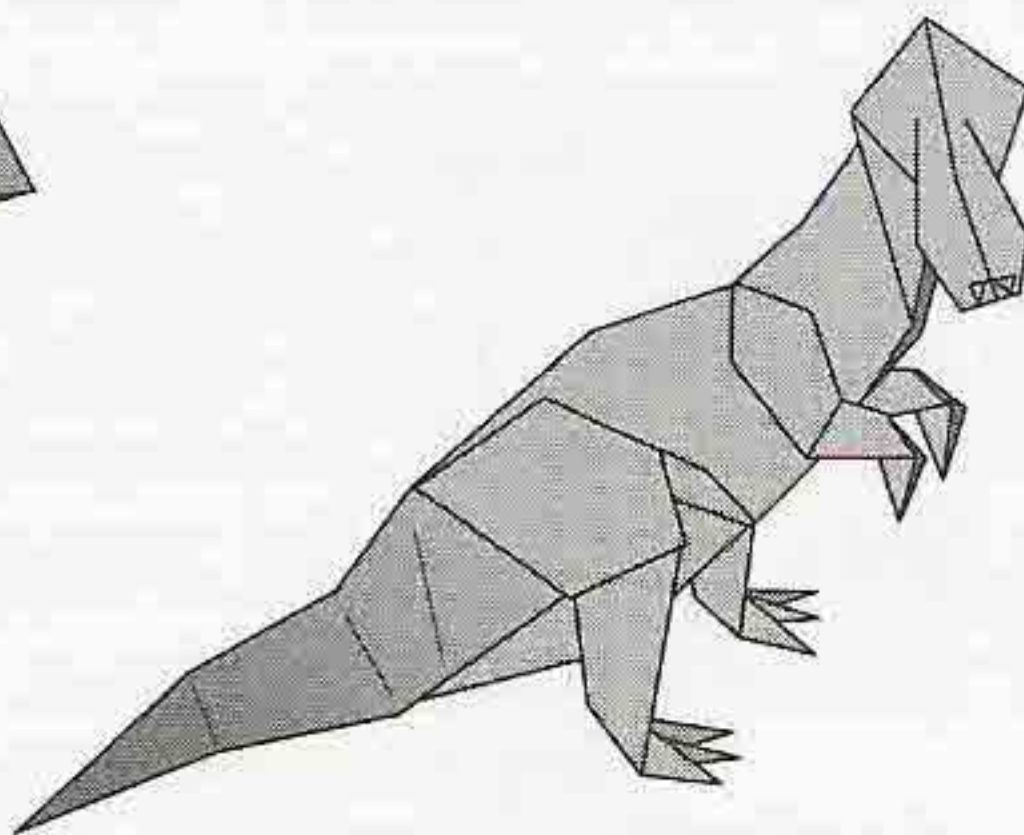

Hadrosaurus

Page 85

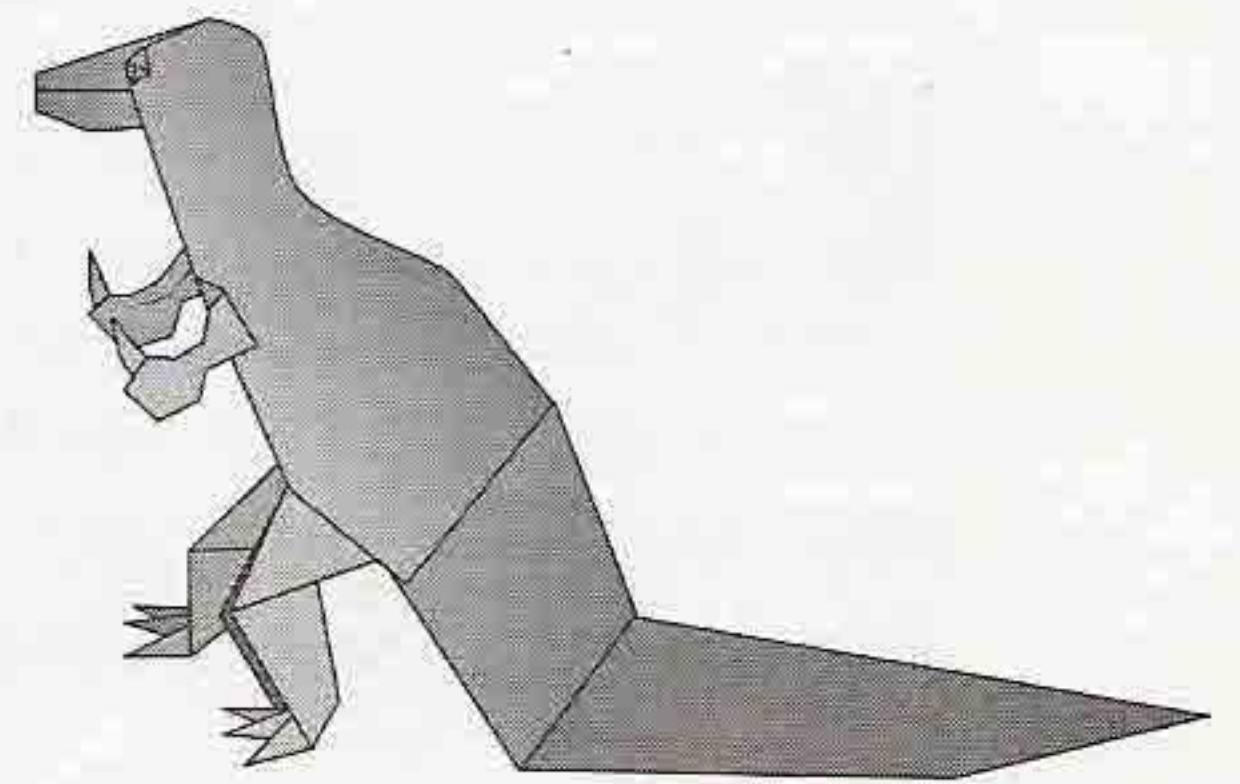

Iguanodon

Page 90

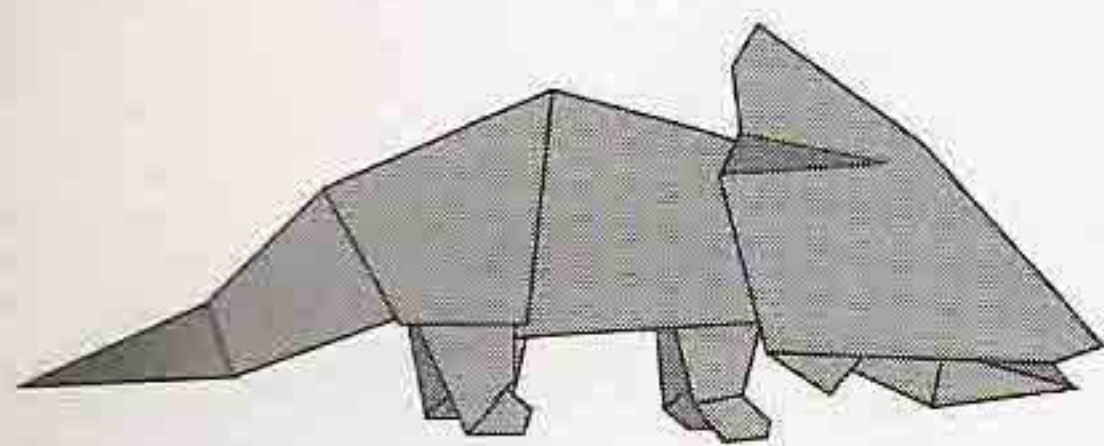

Protoceratops

Page 97

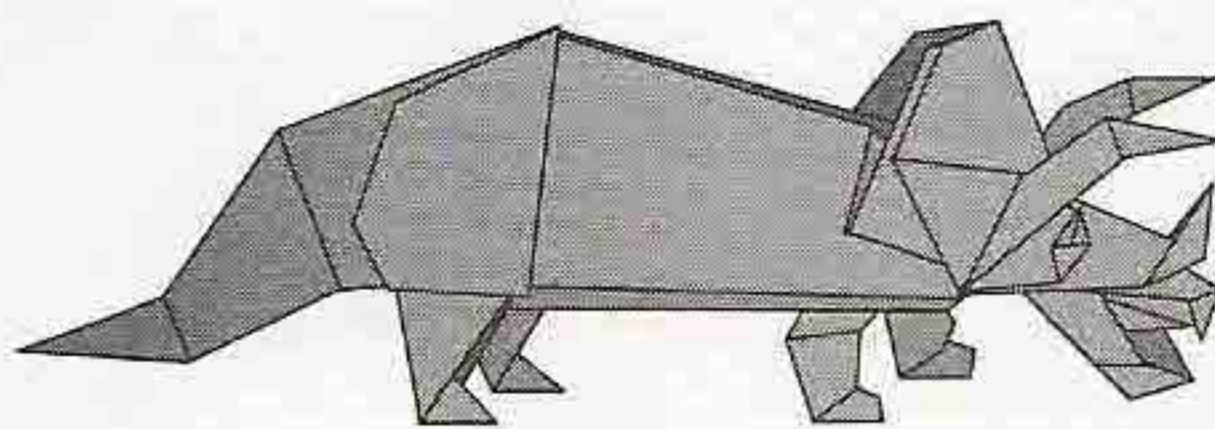

Triceratops

Page 101

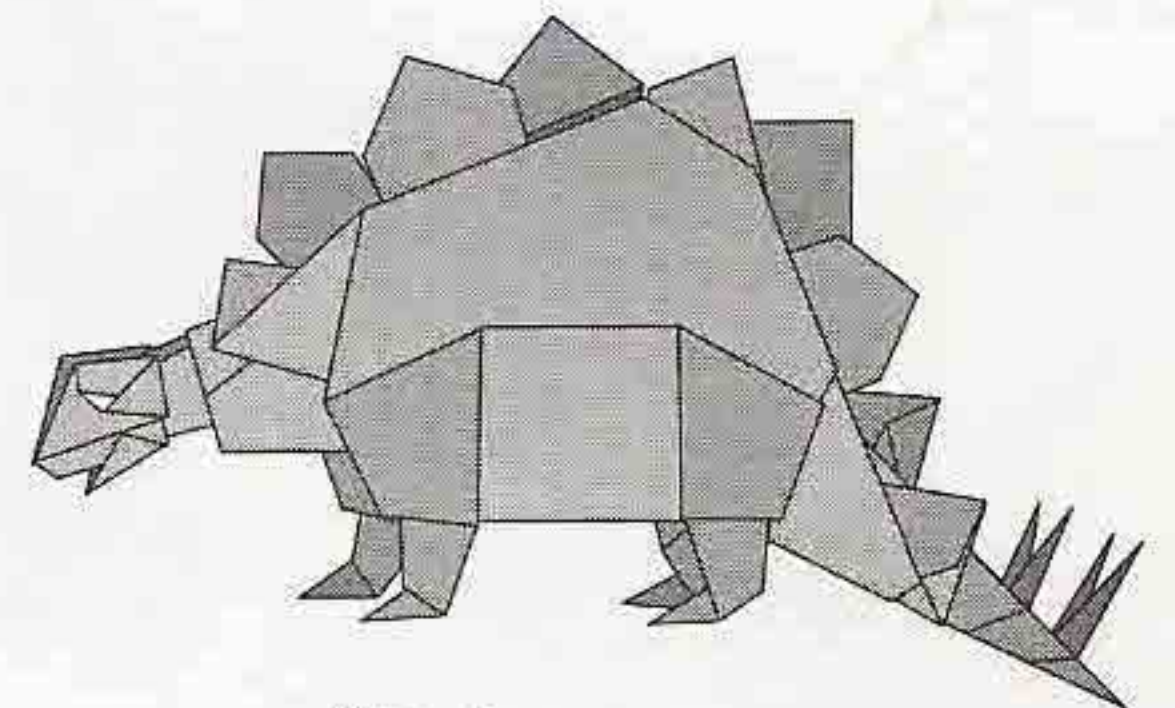

Stegosaurus

Page 110

To Define a Dinosaur

Dinosaurs lived in the Mesozoic (mezz-oh-ZOE-ik) Era which began 225 million years ago and lasted for 155 million years. Mesozoic means “middle life”. The era is divided into three periods.

Dinosaurs appeared on earth during the Triassic (try-ASS-ik) Period. It lasted for 45 million years. All the continents were connected in one giant land mass. There were only a few kinds of dinosaur. These were mostly small, quick, meat eaters.

The Jurassic (joo-RASS-ik) Period began 180 million years ago and lasted for 45 million years. The continents began to move apart and shallow seas and swamps formed. The climate was tropical. The largest dinosaurs lived at this time.

The Cretaceous (kre-TAY-shus) Period is the time the most varieties of dinosaurs lived. It was 65 million years long. The continents were well separated. The climate was seasonal and flowers appeared on earth for the first time.

To be a dinosaur an animal must have a specific skull and hip structure. One way scientists classify reptiles is by the number of holes in the back of the skull. These holes may be to accommodate jaw muscles. They lighten the weight of the skull. All dinosaurs are diapsids (di-AP-sids), having two holes in their skulls.

The Ornithischian (orn-ith-ISK-ee-an) dinosaurs have the two lower bones of the hip pointing towards the back. They have a beak-like addition to the jaw bone. Some were plant eaters and some were meat eaters. Ornithischian mean “bird-hipped”. The Saurischian (sawr-ISK-ee-an) dinosaurs have each hip bone pointing in a different direction. They have a solid jaw and are meat eaters. Saurischian means “lizard-hipped”.

All true dinosaurs were land dwellers. However, some dinosaurs, like many other land dwelling animals, would sometimes wade or swim.

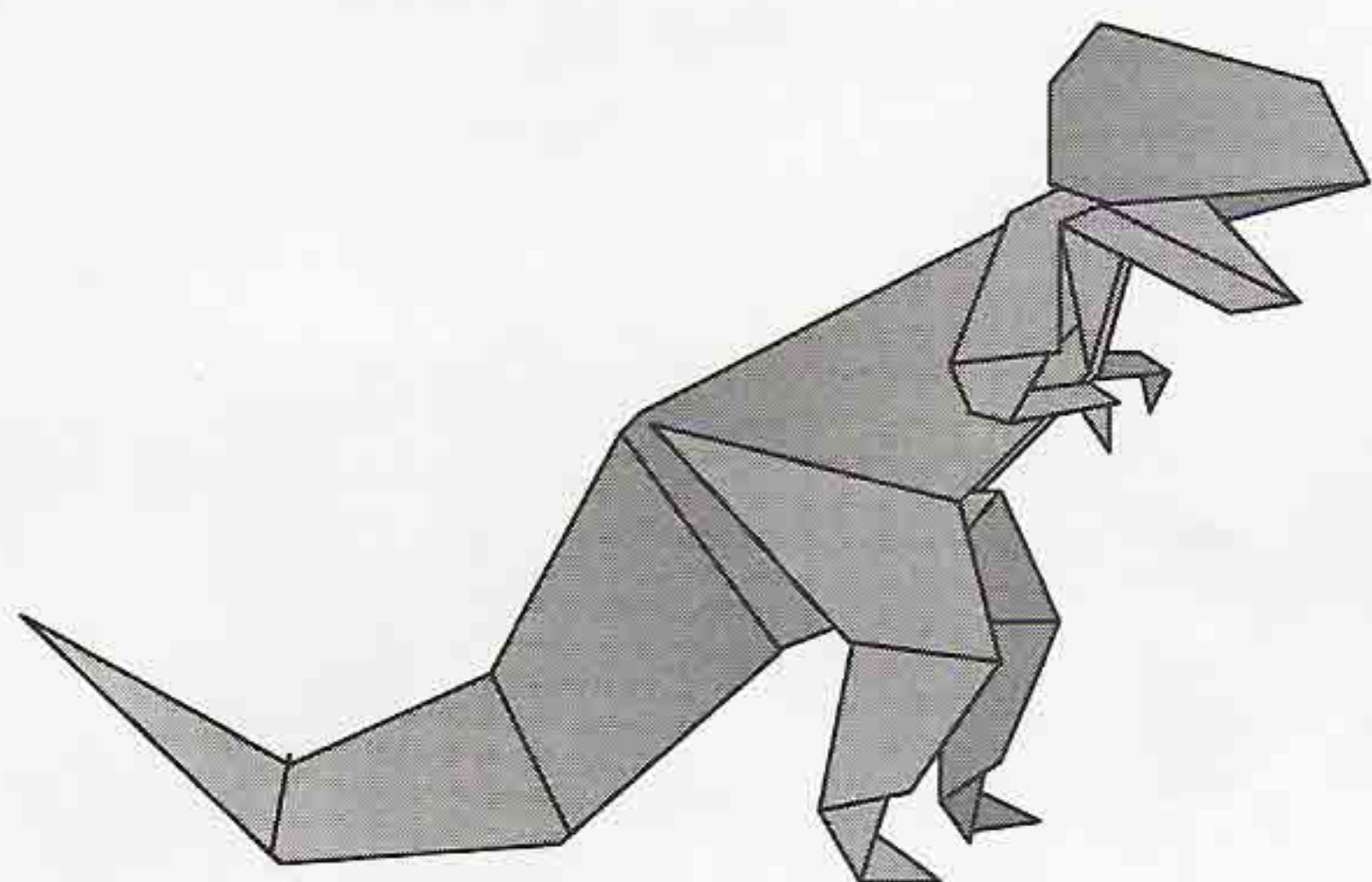

The Tyrannosaurus is an Ornithischian dinosaur which lived during the Cretaceous Period.

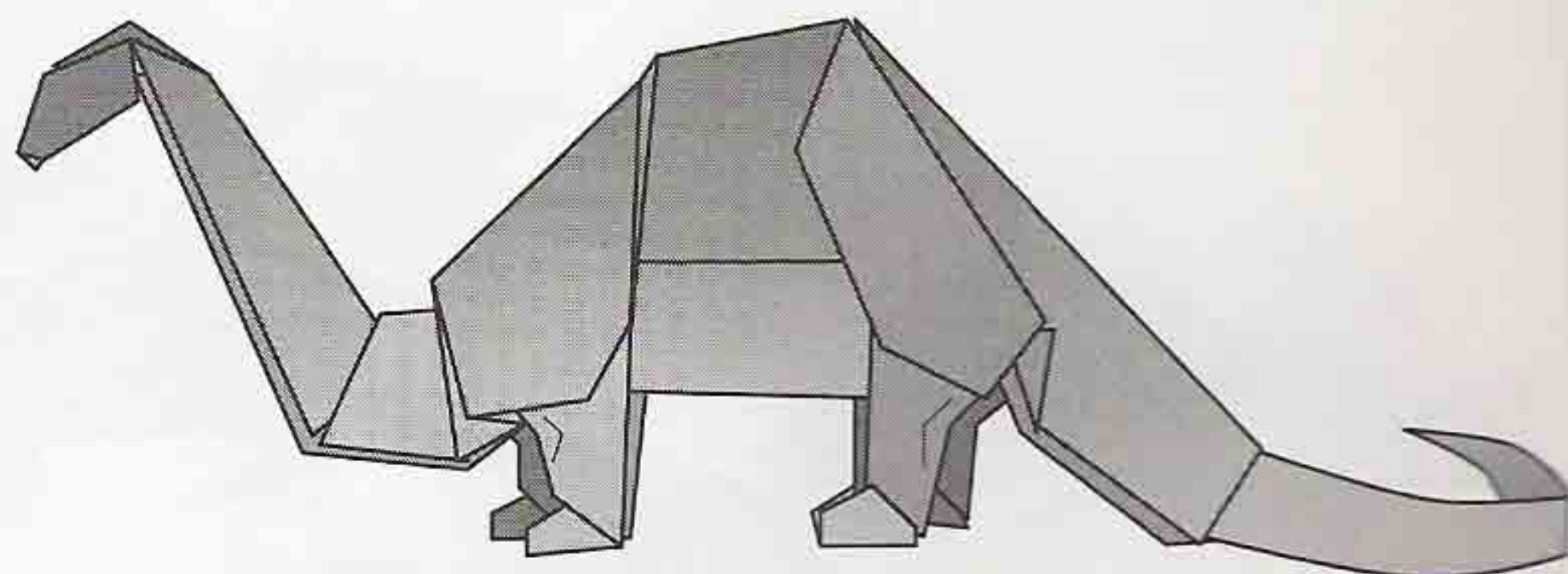

The Apatosaurus is a Saurischian dinosaur which lived during the Jurassic Period.

Martha Landy

Wet Folding

Sometimes, you find that thick, textured, or leathery papers in your collection look like they would make wonderful origami, until you work with them. After very few folds, they become torn and ugly. If a favorite sheet has become old and brittle, it does not fold well, either; it breaks!

Before you give up on uncooperative paper, try wet folding. The results are greater flexibility and solid, long-lasting models. As the paper dries, its own adhesives hold your folds stiffly and permanently. (Purists ignore this: A drop or two of white GLUE to a cup of water adds body to soft paper.)

How much water should be used? The amount varies with the kind of paper you choose. Start by dampening the underside of your paper with a squeezed out washcloth or sponge. A spray bottle or wet hands work just as well. Soaking the paper makes it fall apart. If it gets too wet, wait until some water evaporates. Wet folding can be messy. Some papers flop apart when you least appreciate it.

Fold your models slowly and carefully, with fingertips, not nails. Sharp creases can tear. While you fold, notice how moisture evaporates from different papers at different rates. Re-wet parts of the model as you work, so that your paper stays flexible.

An added attraction is to make the model three dimensional. While it is still wet, the head, tail, legs, and body can be rolled or pinched to look like hollow, 3-D tubes. Many models will dry as you handle them and mold them into place. If others do not stay in position while you shape them, use paper clips or thin wire to keep them where you want them. The wire can pose each part, like a sculpture, creating the exact personality you prefer for the model. Remove wire and clips after the paper is dry.

Unlike foil that remembers every mistake you made, you can re-wet and re-fold small parts of your model without ruining it. This is helpful when making adjustments for free standing subjects.

Depending on the type of paper, your model will dry within a few minutes to overnight. If you discover that your masterpiece was made from waterproof, vinyl coated paper, just be more patient! From simple folds to the ridiculously complex, wet folding adds another dimension to your origami.

Rosalind Joyce

Apatosaurus

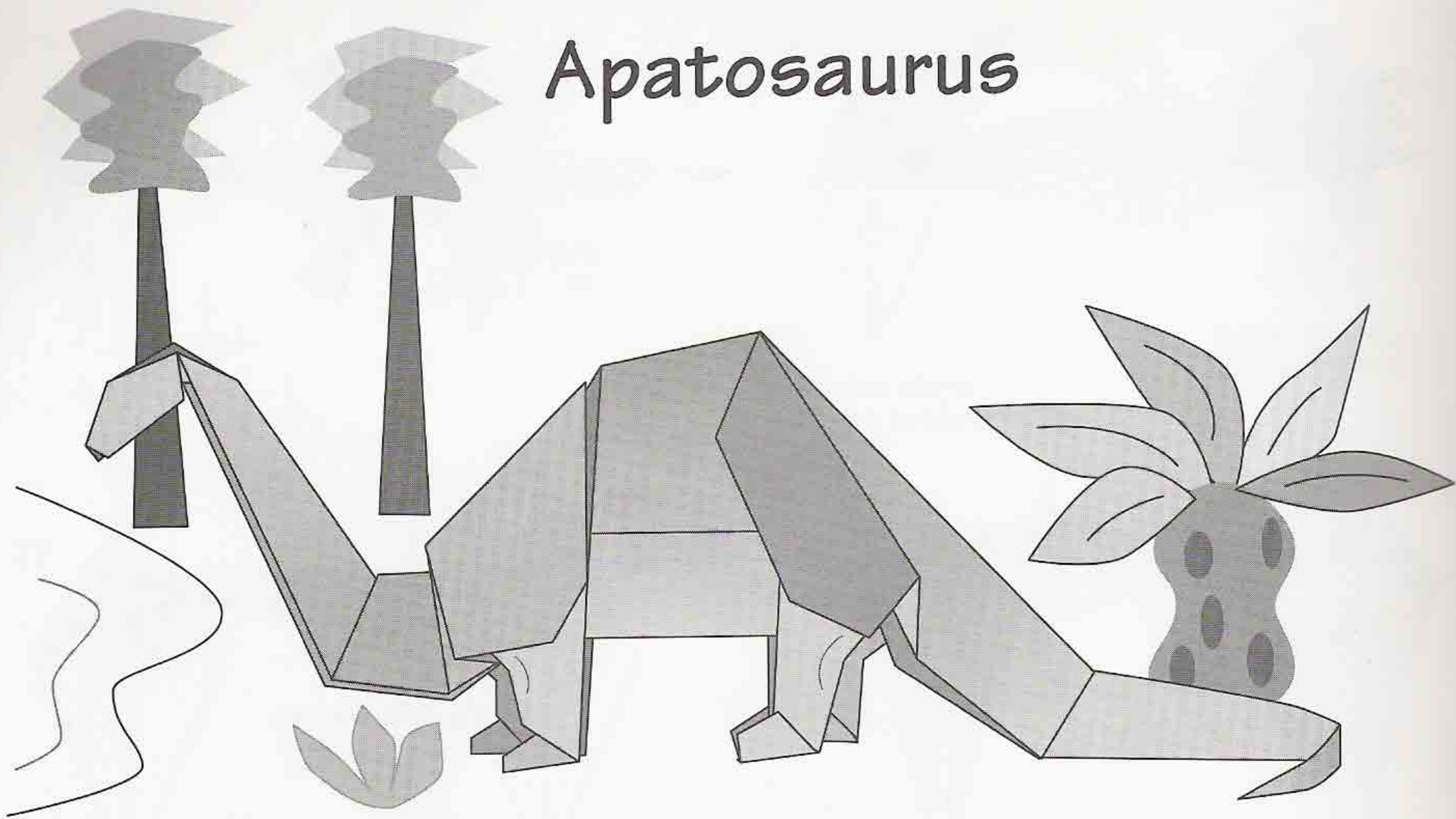

a-PAT-oh-saw-rus

This dinosaur is better known as Brontosaurus, the “thunder lizard” but more correctly named Apatosaurus, the “headless lizard”. It was 70 feet long and very heavy. The front legs were shorter than the back legs. Its fossils were found in the western U.S. with other Jurassic dinosaurs. Its small flat teeth could not have ground up all the food required to fuel this animal so it relied on “gizzard stones” to aid in digestion.

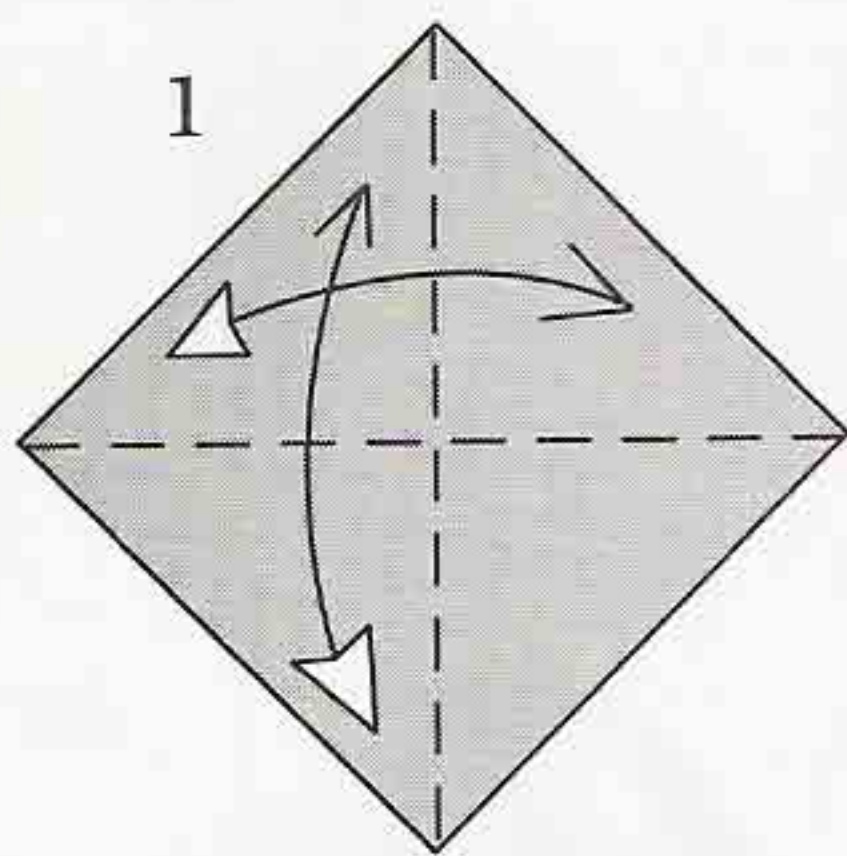

Fold and unfold.

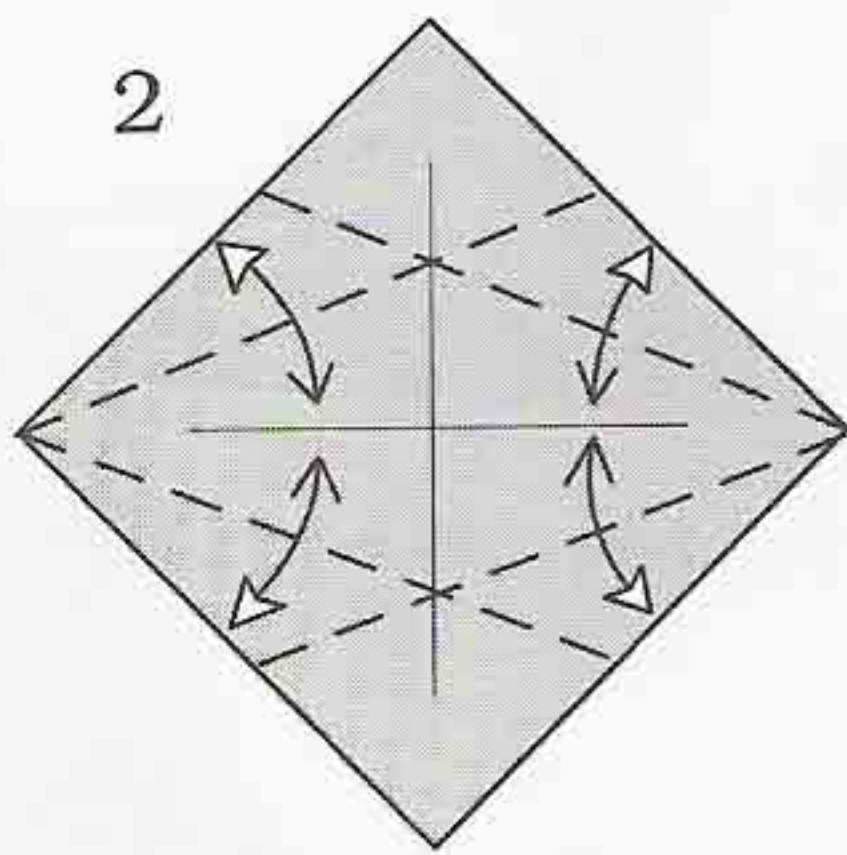

Kite fold and unfold.

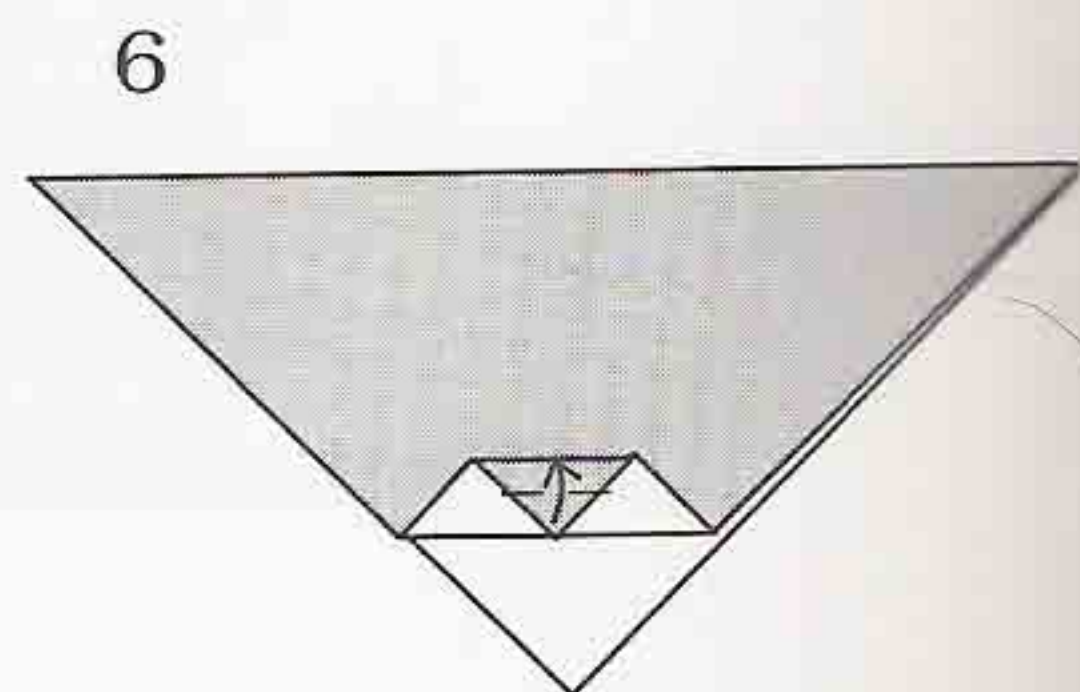
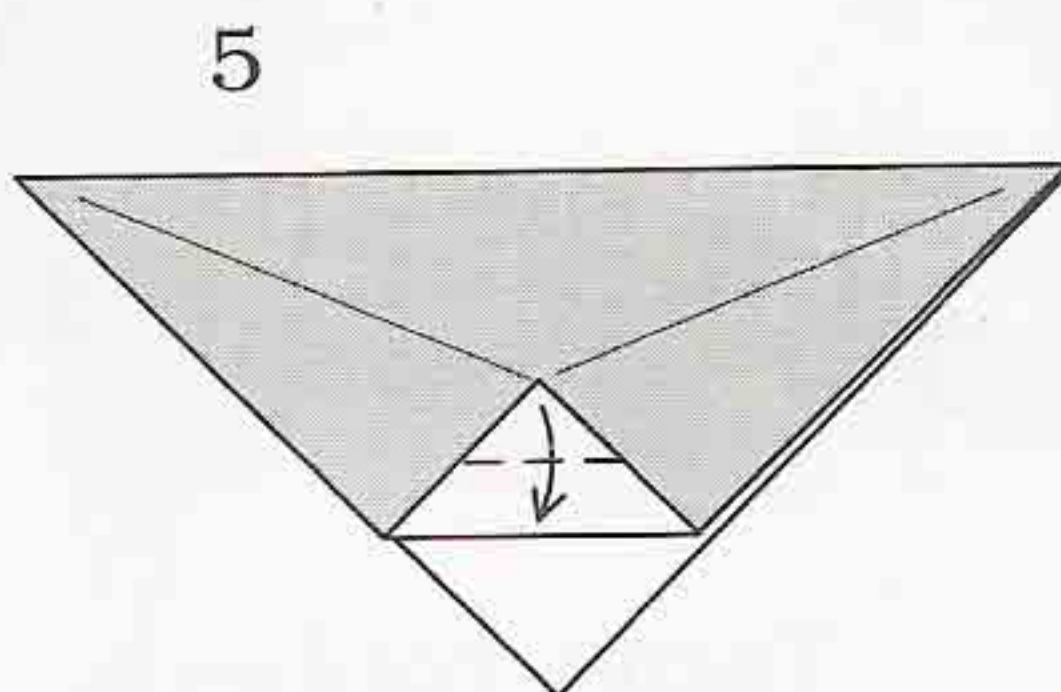
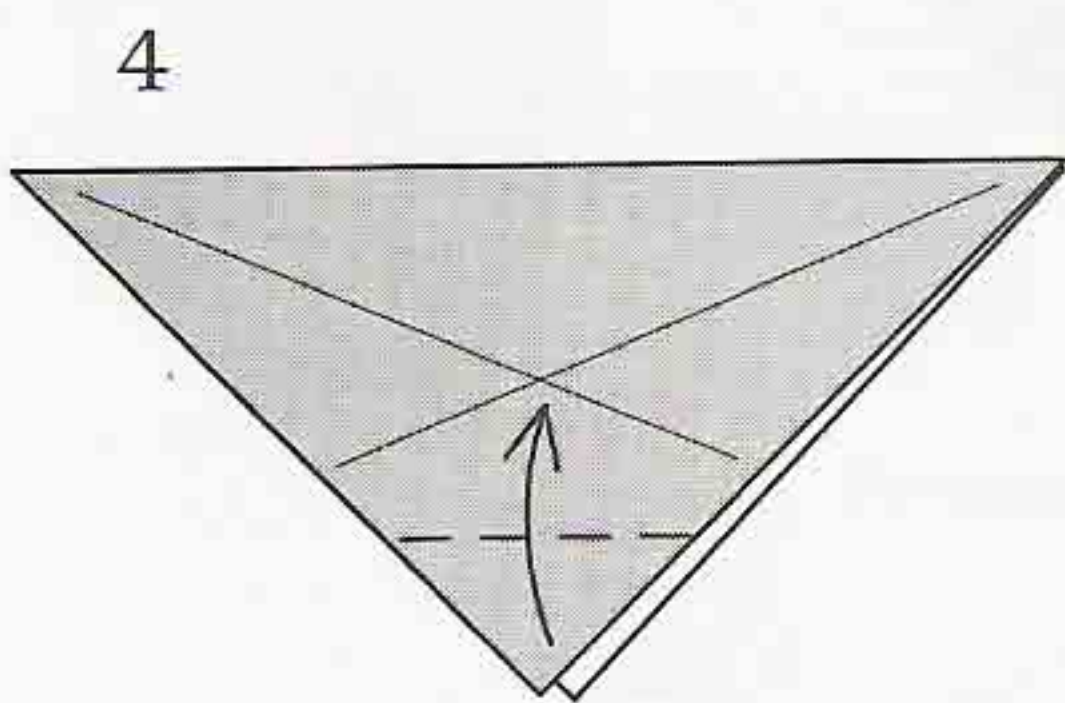
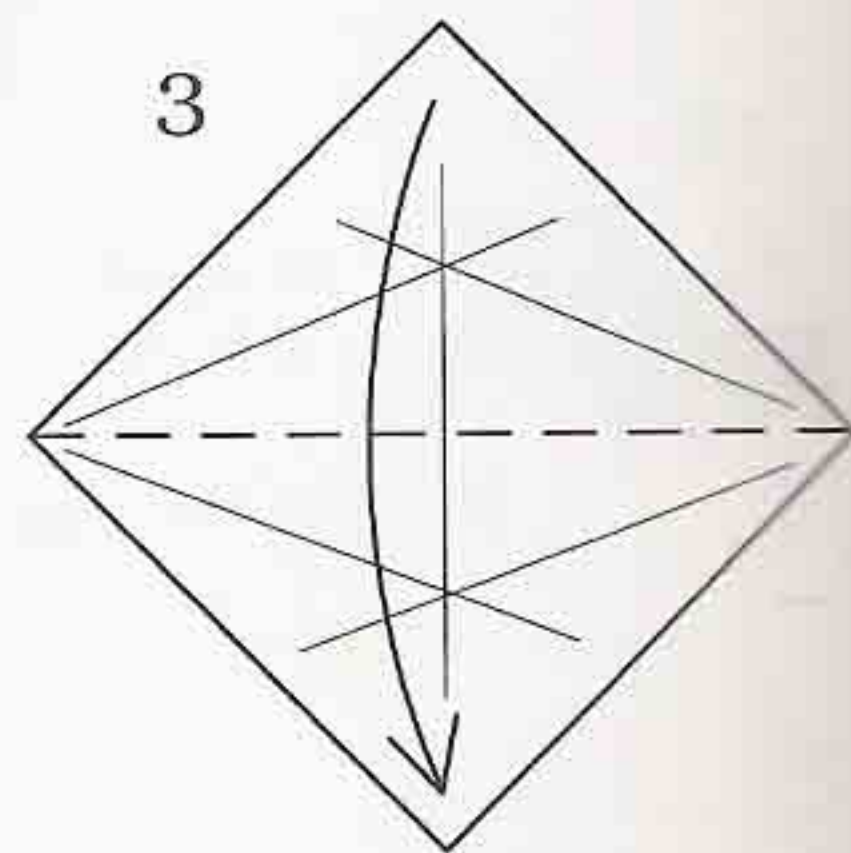
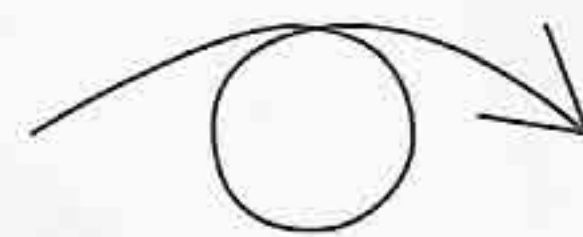

7

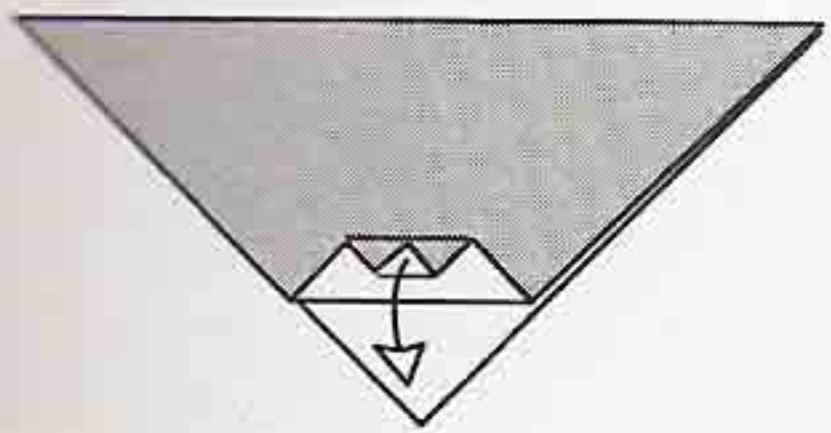

Unfold.

8

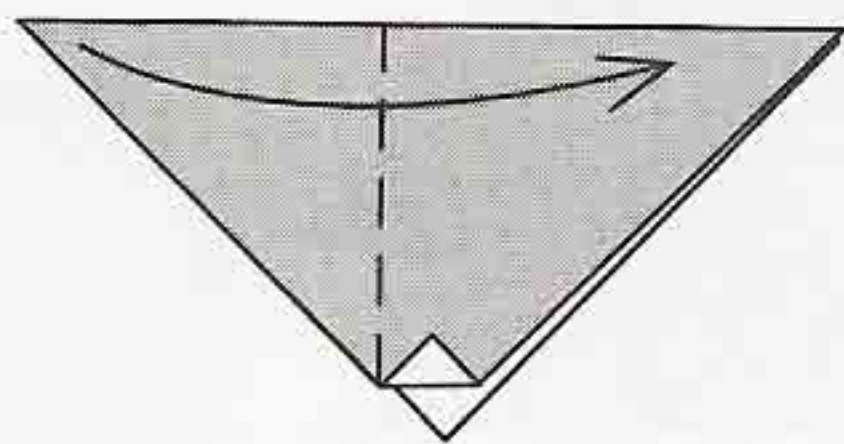

9

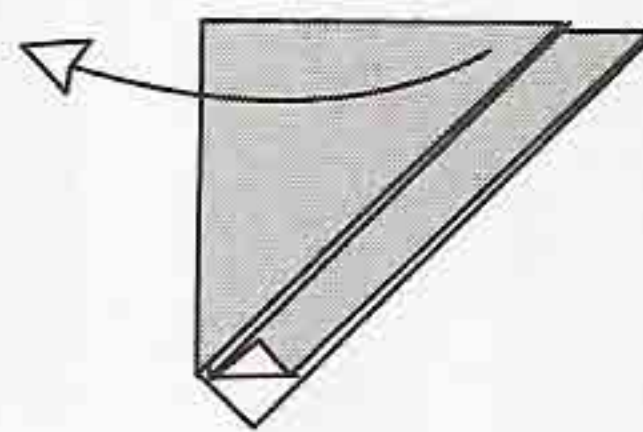

Unfold.

10

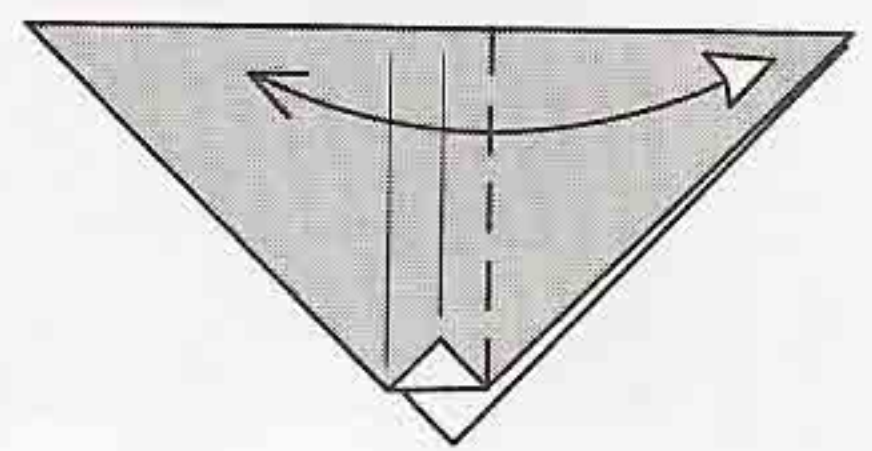

Fold to the left and unfold.

11

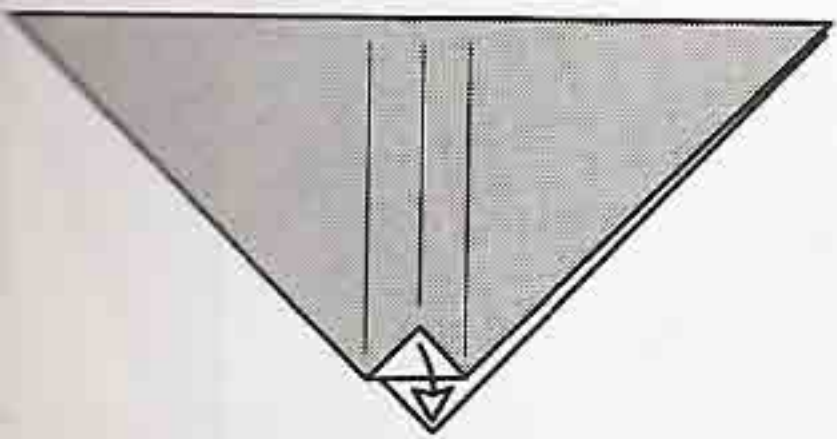

Unfold.

12

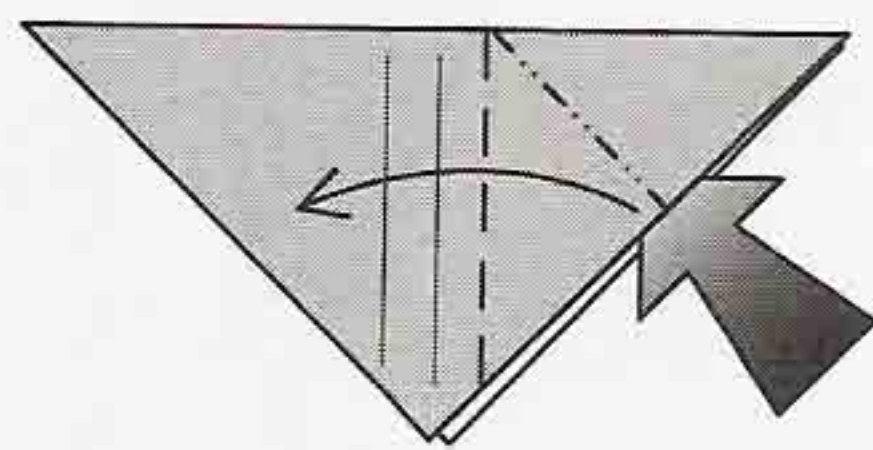

Squash fold.

13

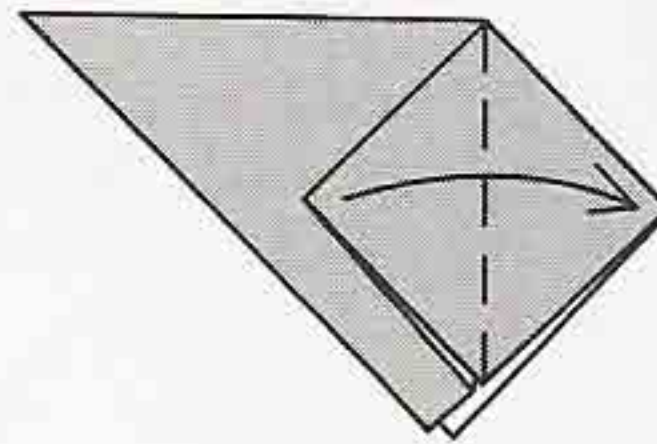

14

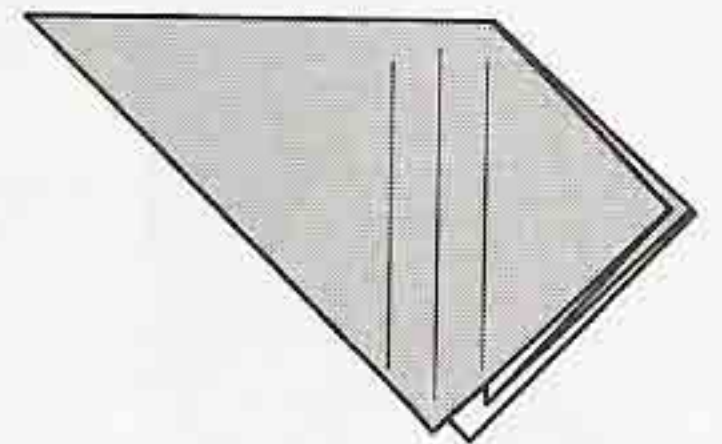

Repeat steps 12-13 on the left.

15

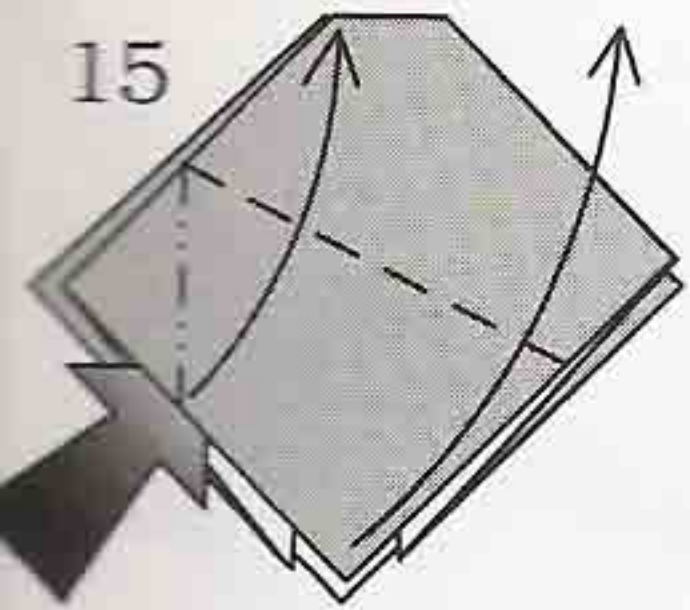

Squash fold.

16

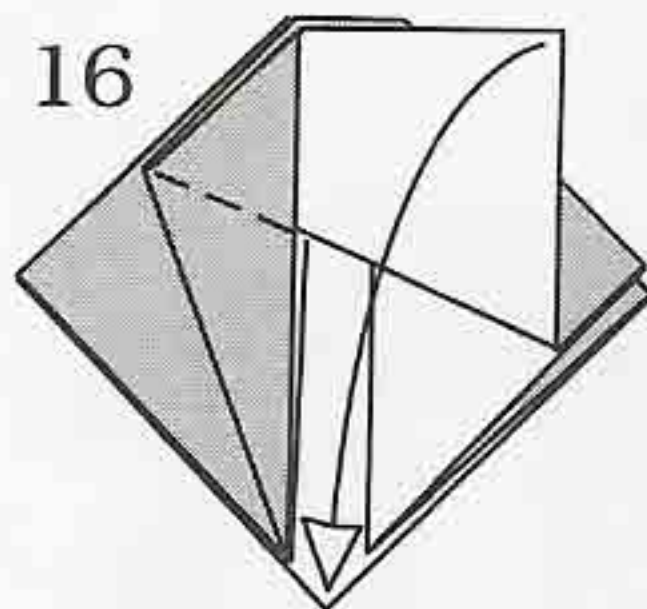

Unfold.

17

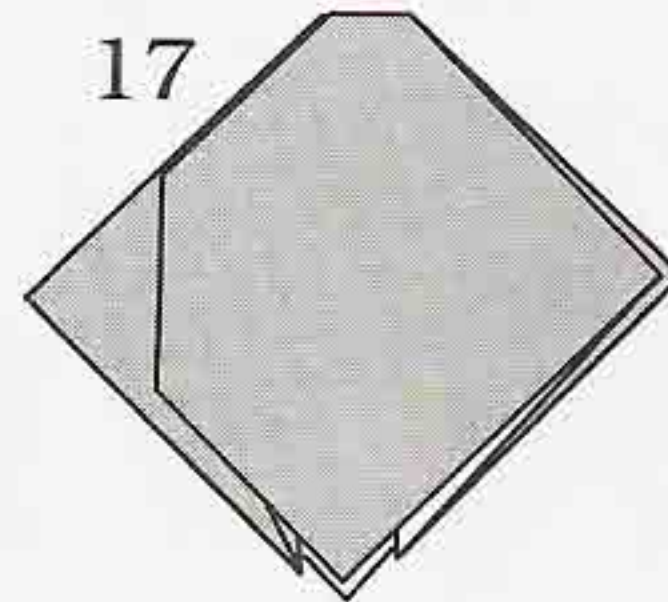

Repeat steps 15-16 on the right and back.

18

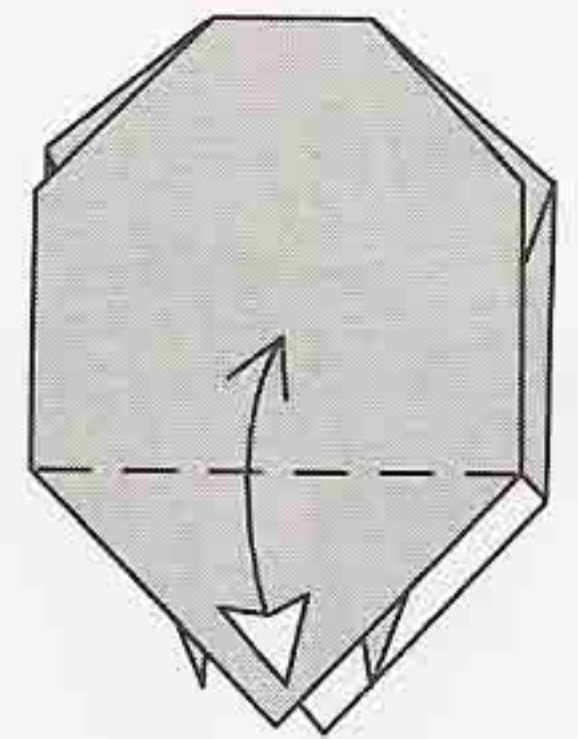

Fold up and unfold. Repeat behind.

19

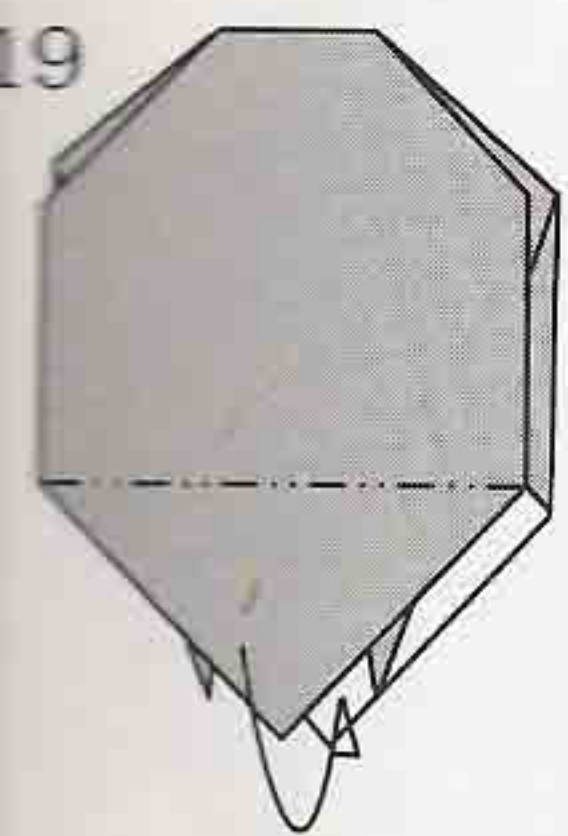

Repeat behind.

20

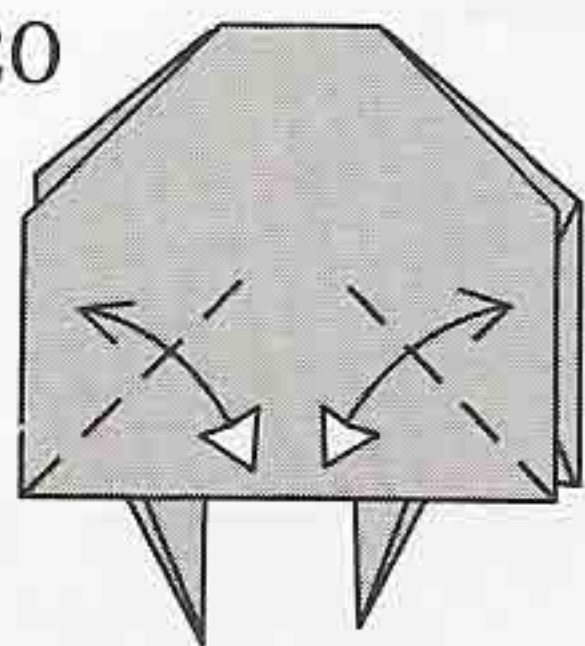

Fold and unfold. Repeat behind.

21

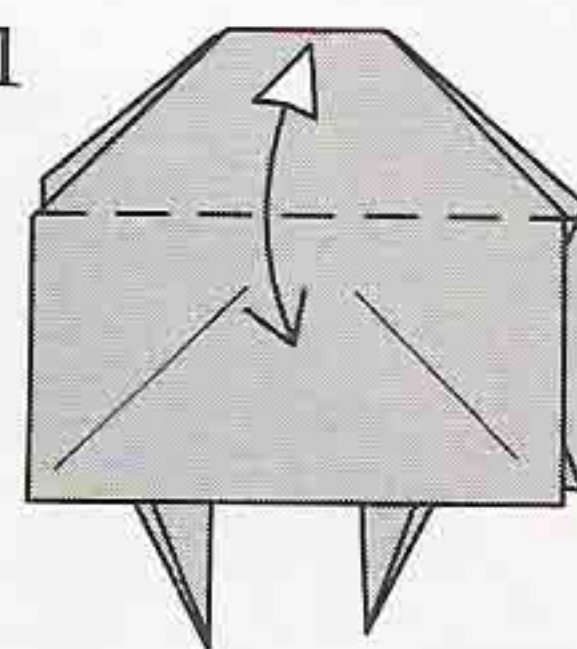

Fold down and unfold.

22

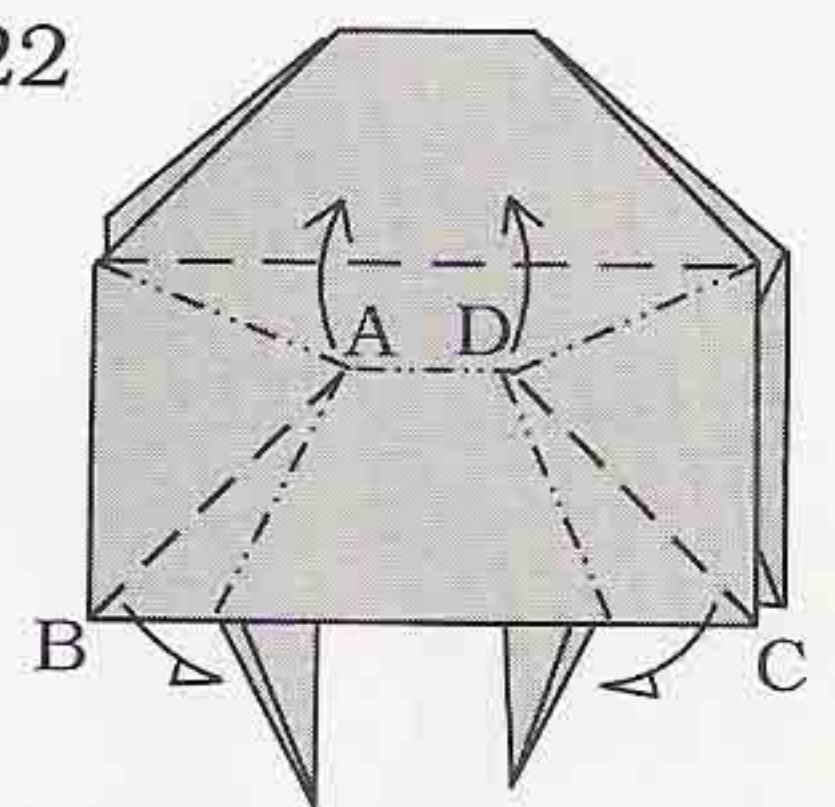

This is a tricky fold! Lift A-D up while bringing B and C closer together.

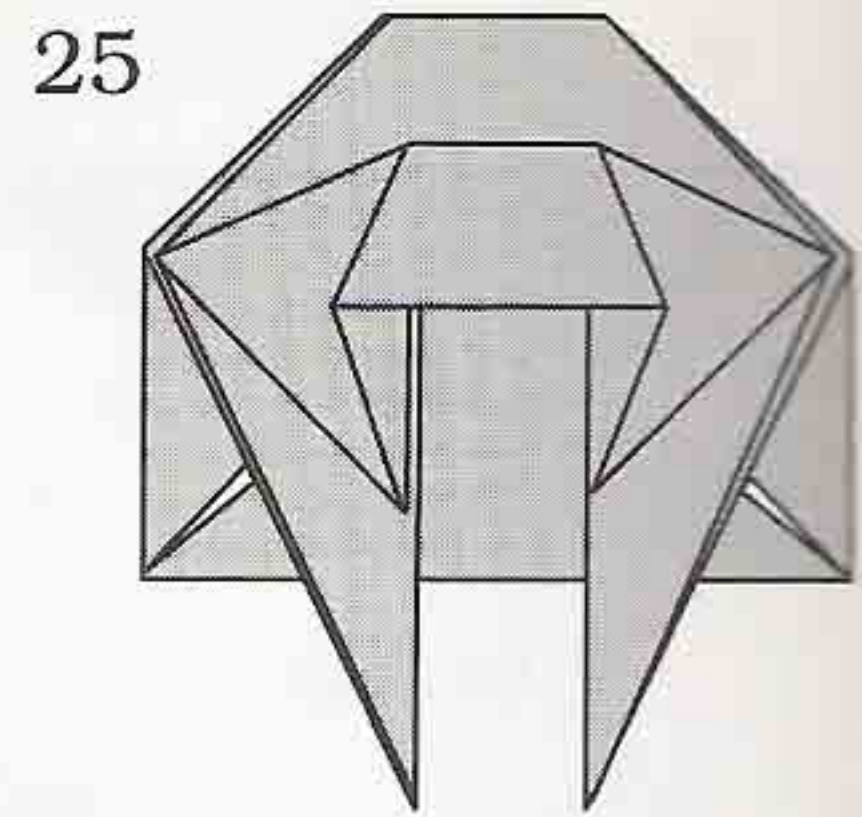
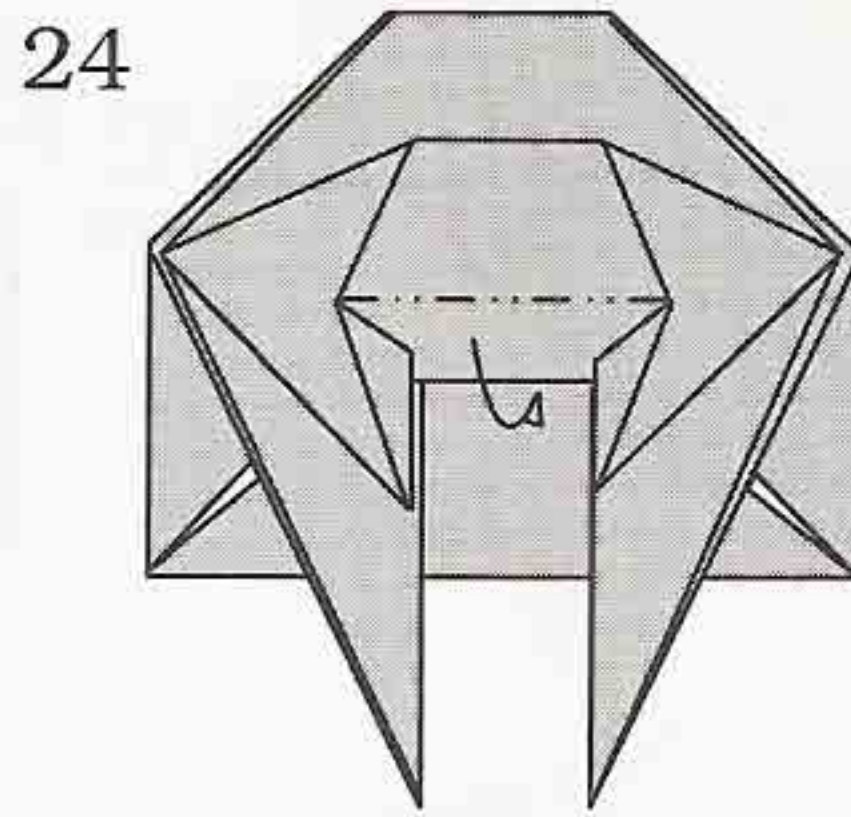
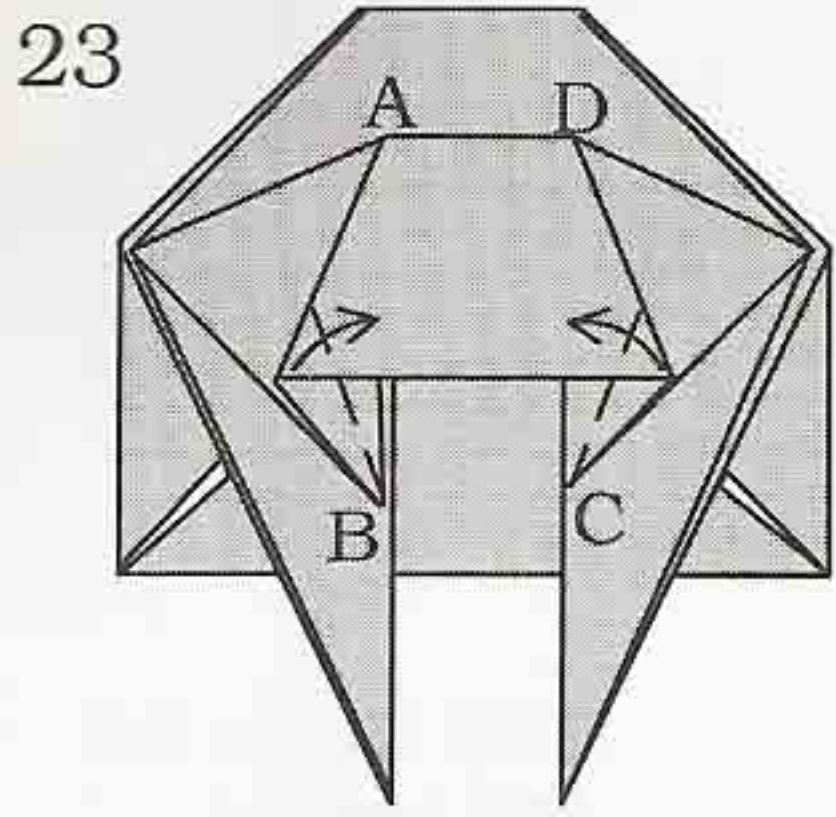

Repeat steps 21-24 behind.

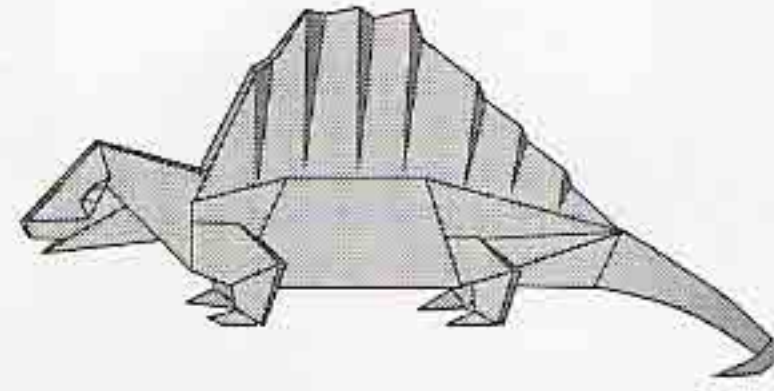
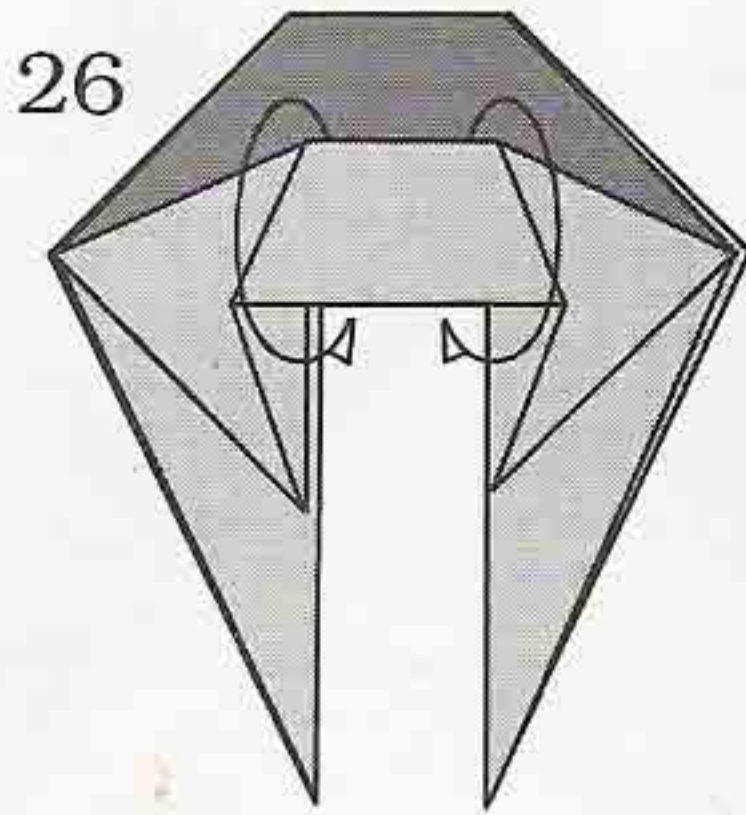

The Dimetrodon (page 71) begins with this step.

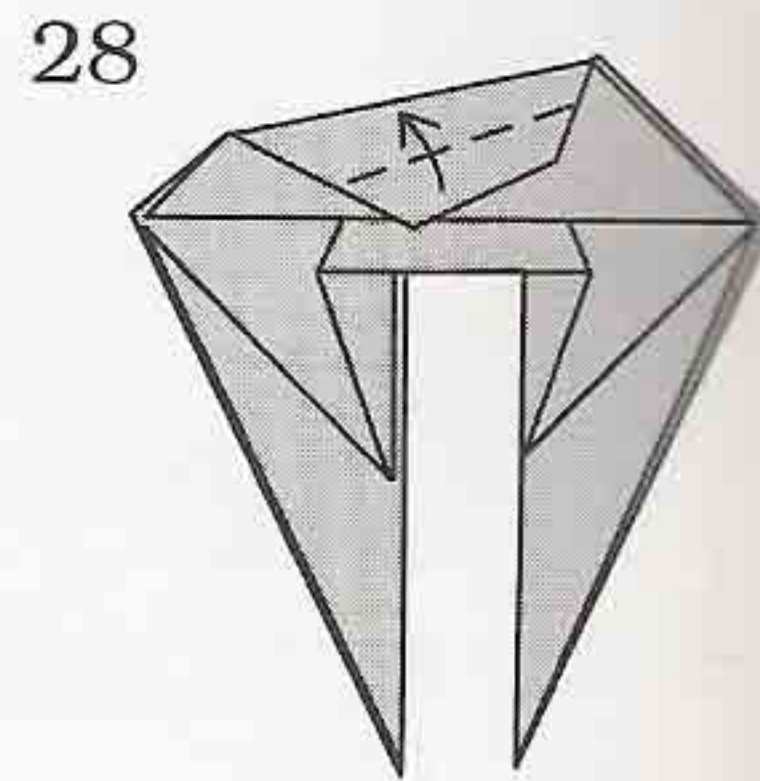
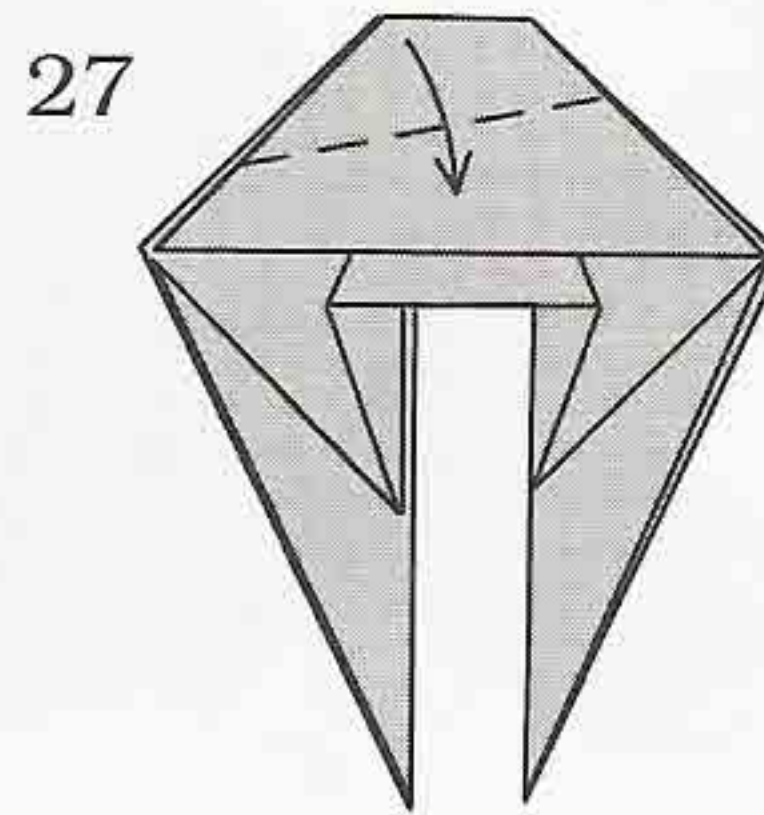

Fold the paper inside so the darker region will be on top. Repeat behind.

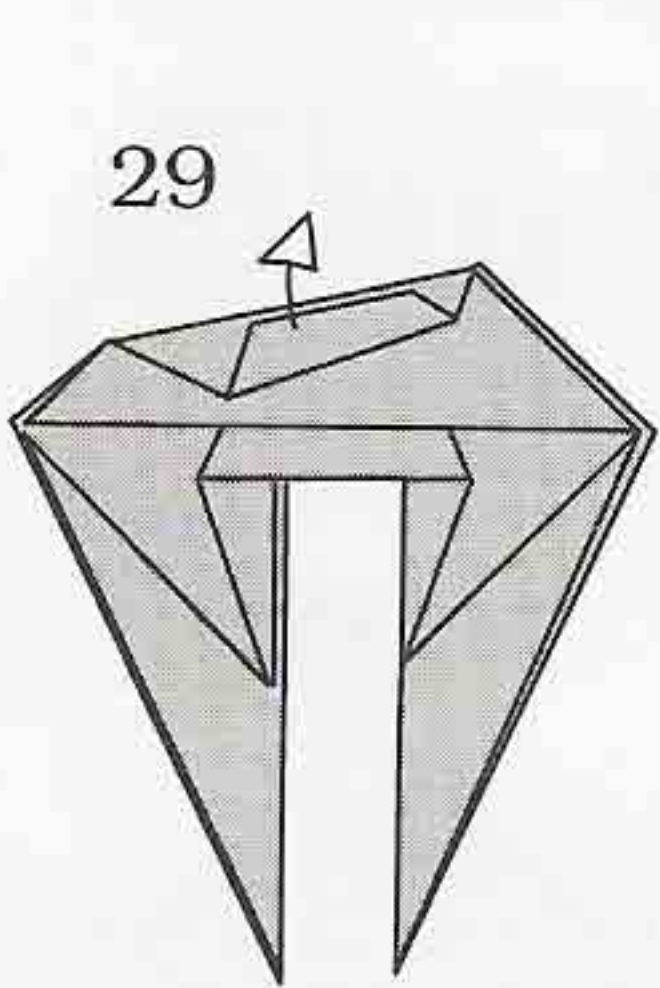

Unfold.

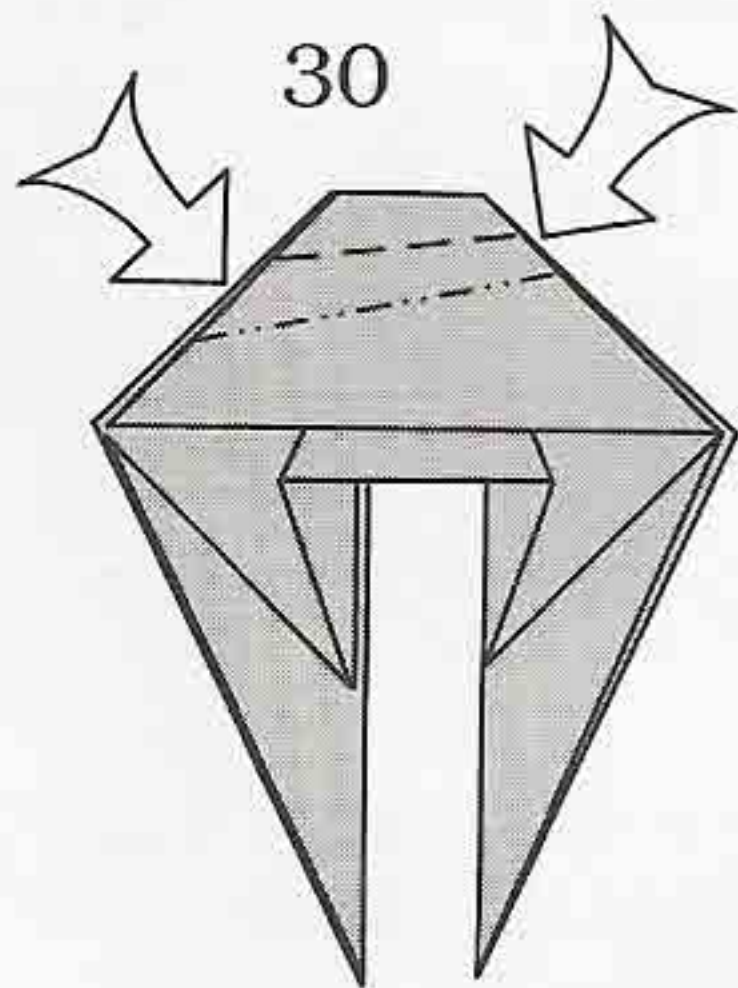

Sink down and up.

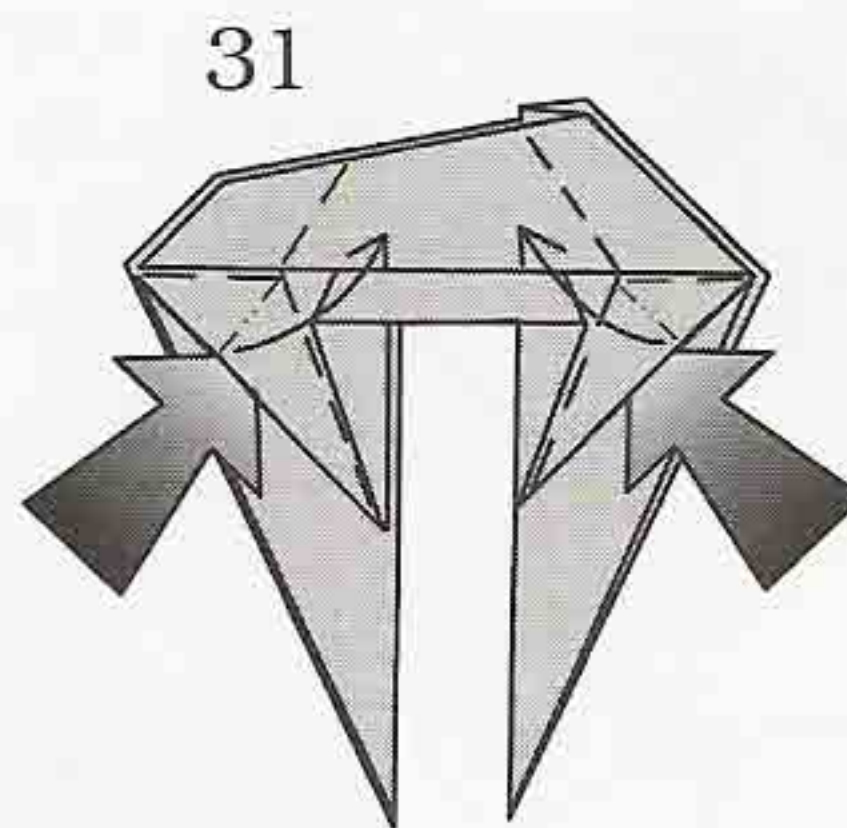

Repeat behind.

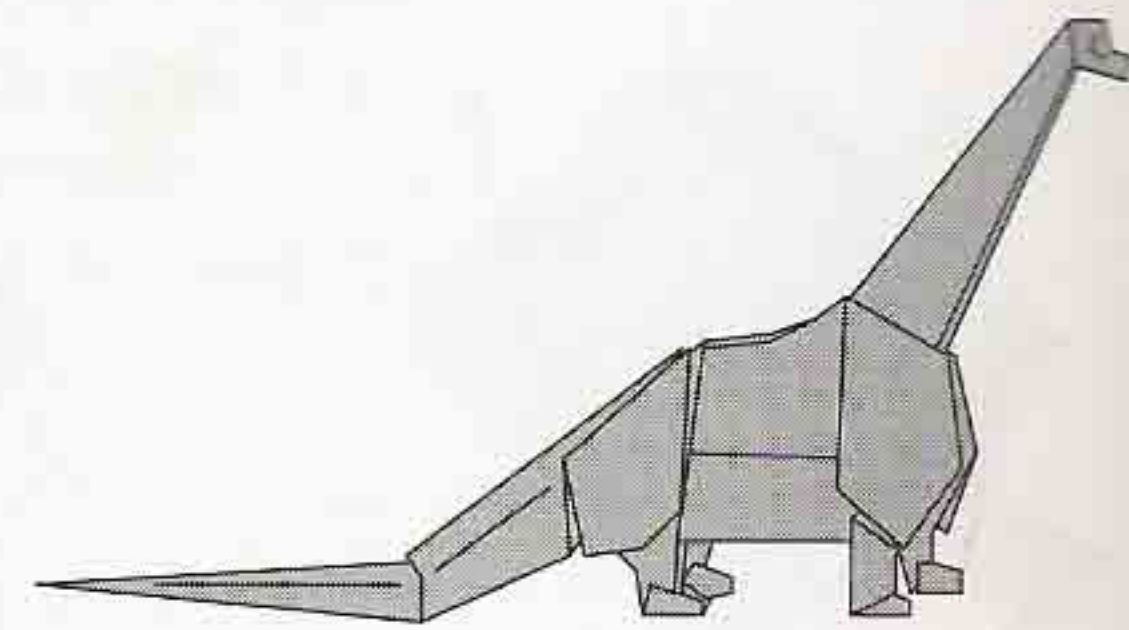

The Brachiosaurus (page 68) begins with this step.

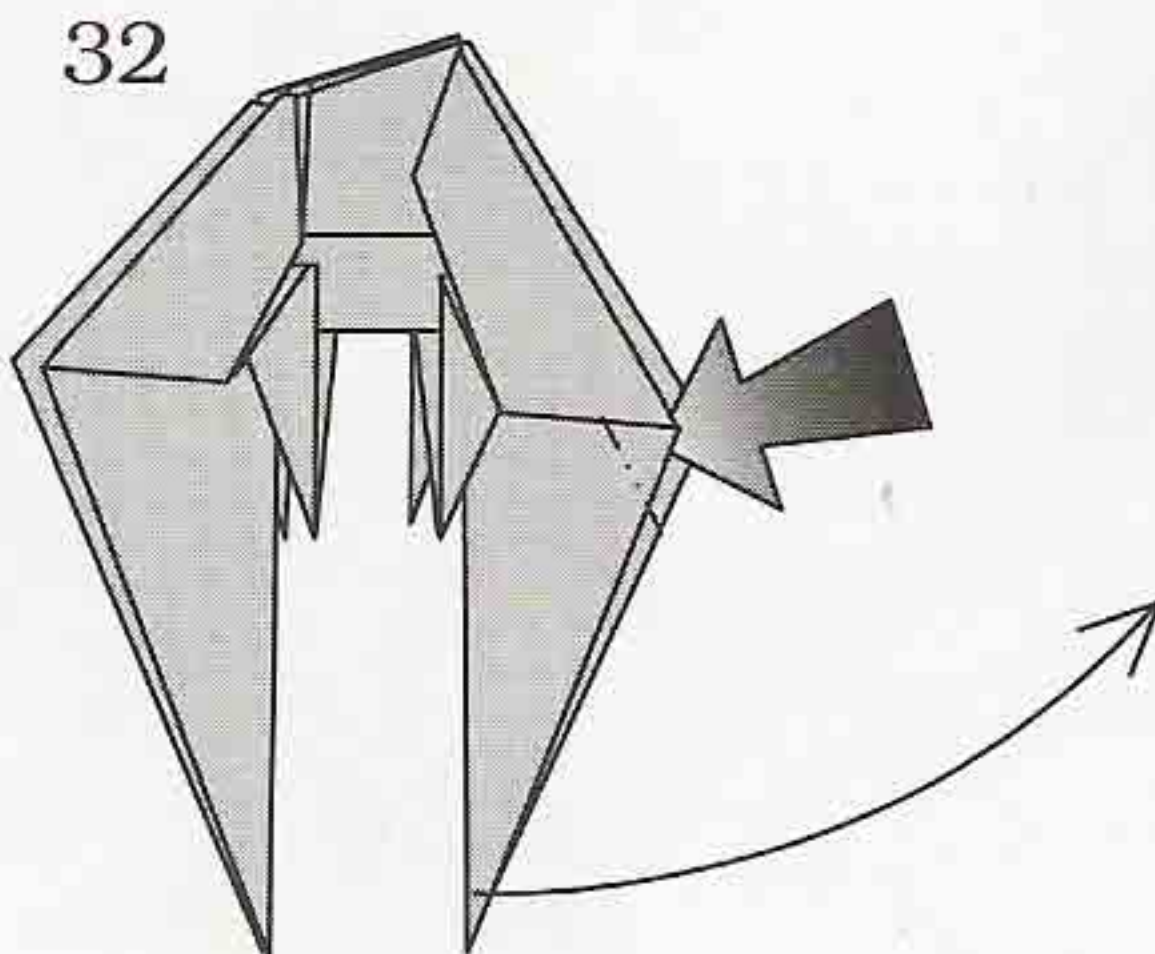

Reverse-fold the tail.

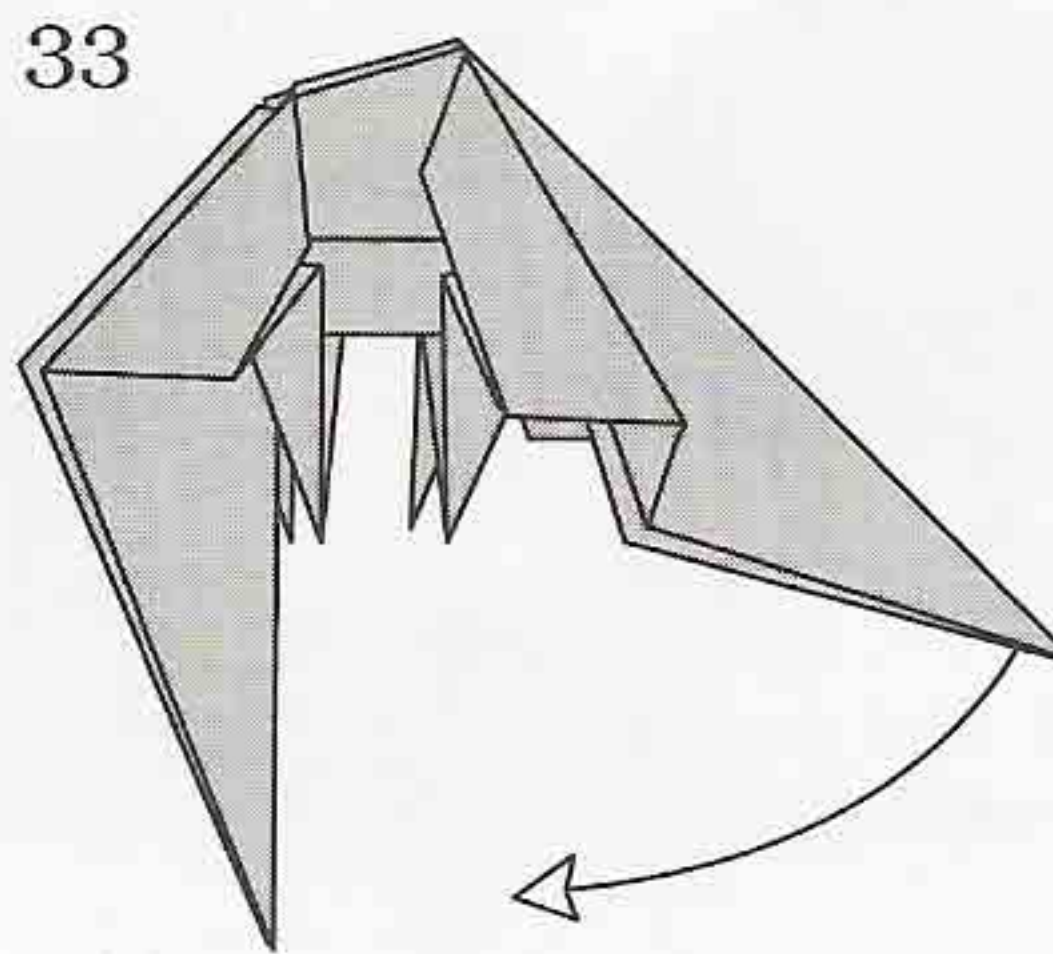

Unfold.

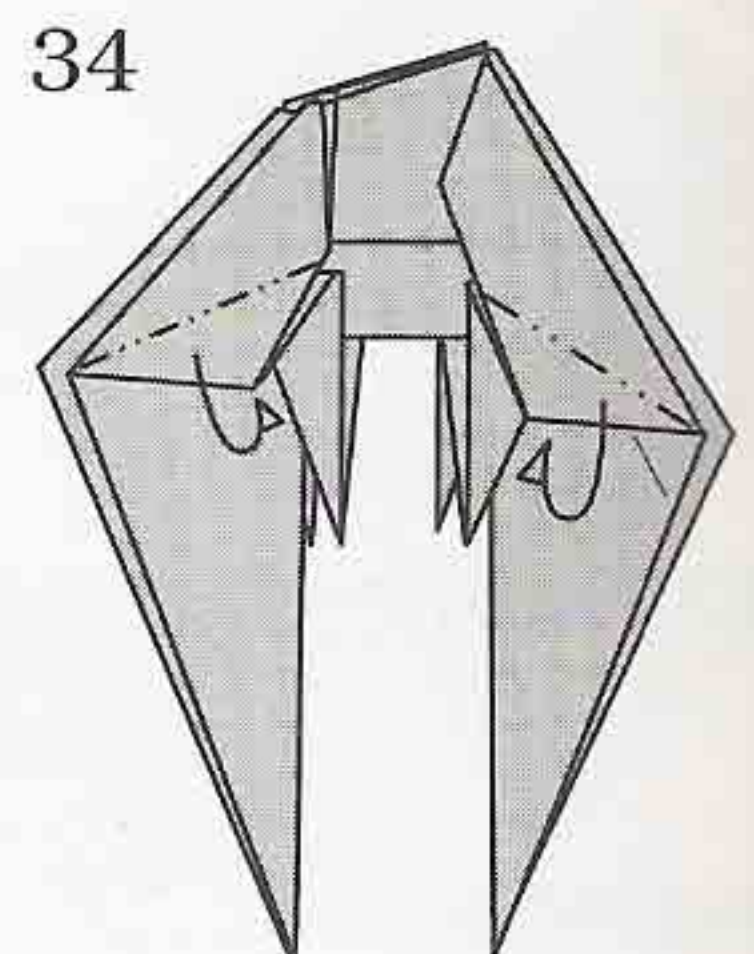

Repeat behind.

35

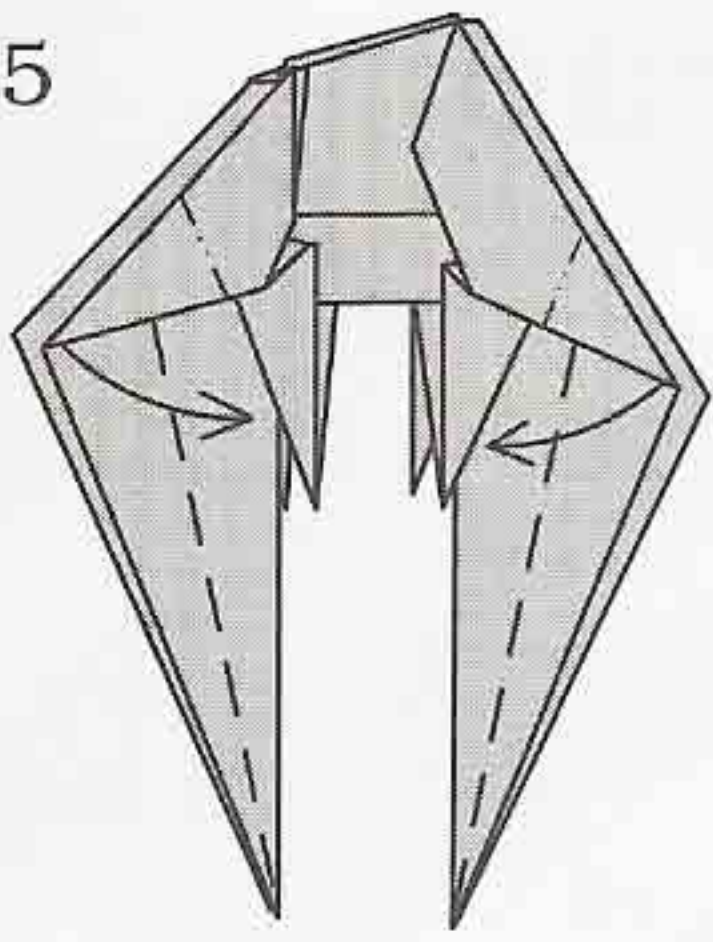

Repeat behind.

36

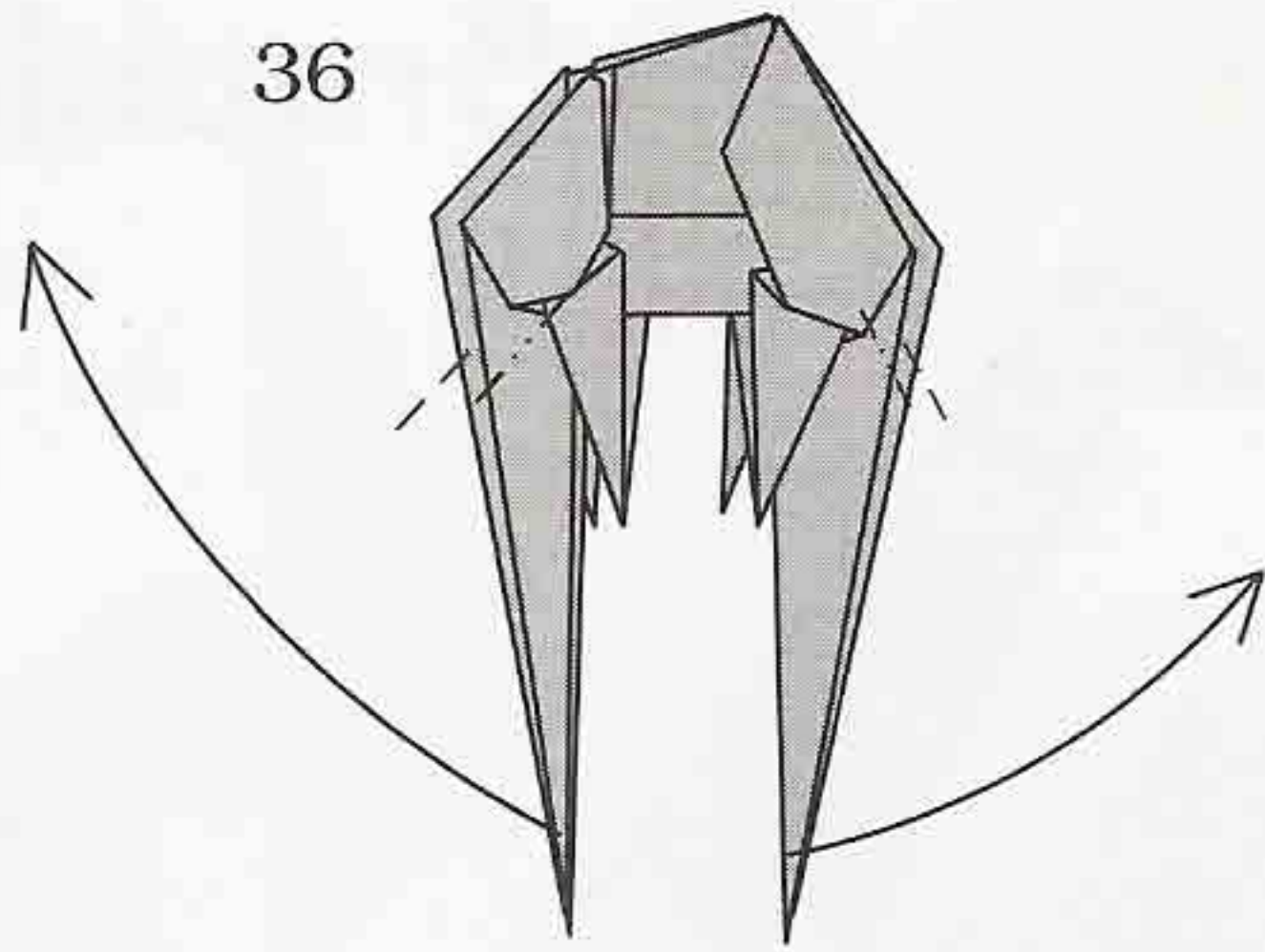

Reverse-folds.

37

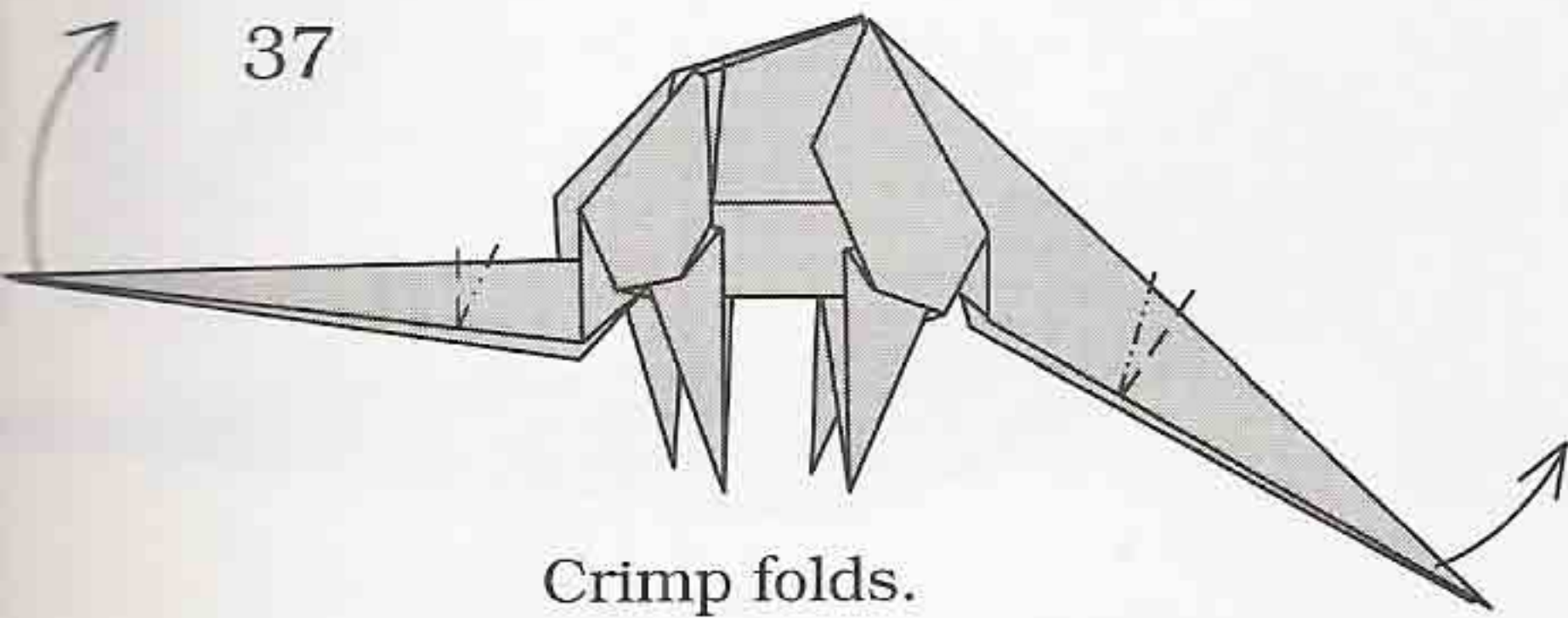

Crimp folds.

38

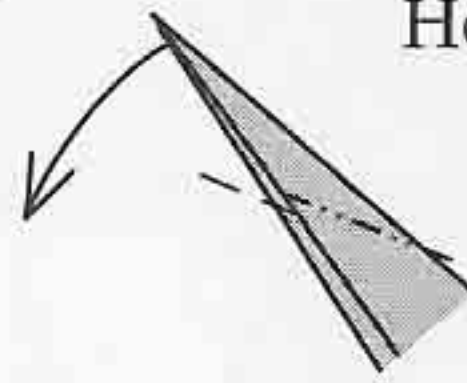

Head.

Reverse-fold.

39

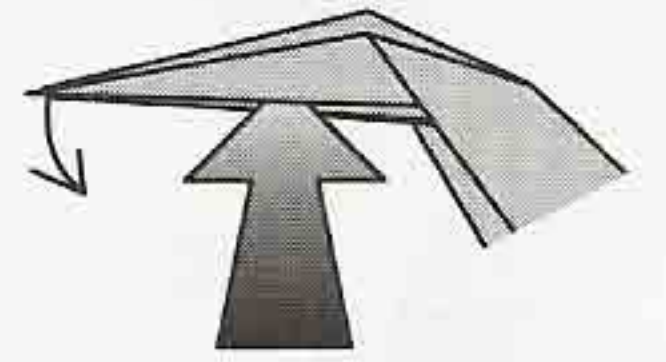

Spread the head while folding it down.

Front legs.

Hind legs.

40

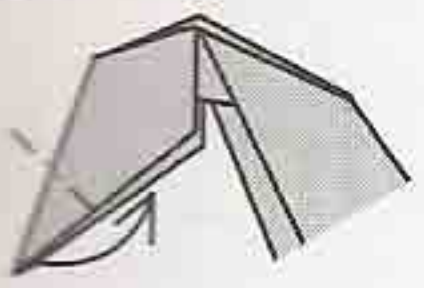

Reverse-fold.

41

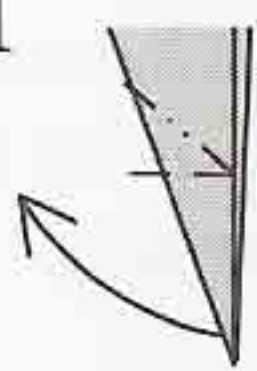

Repeat behind.

42

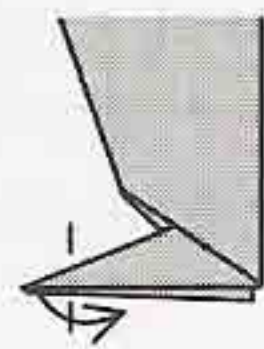

Repeat behind.

43

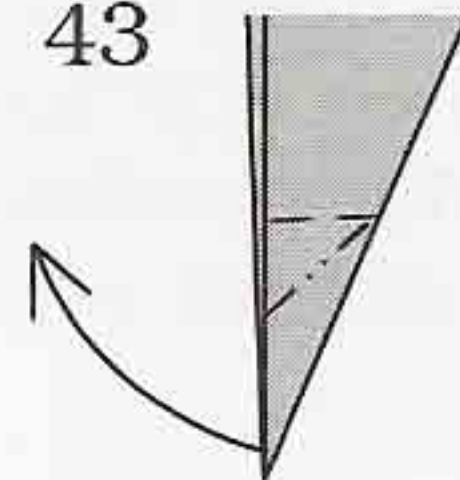

Repeat behind.

44

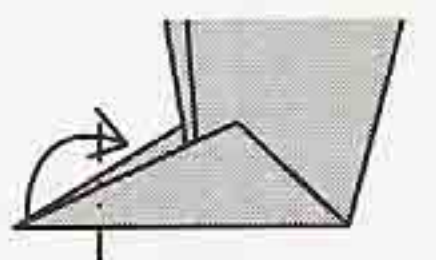

Repeat behind.

45

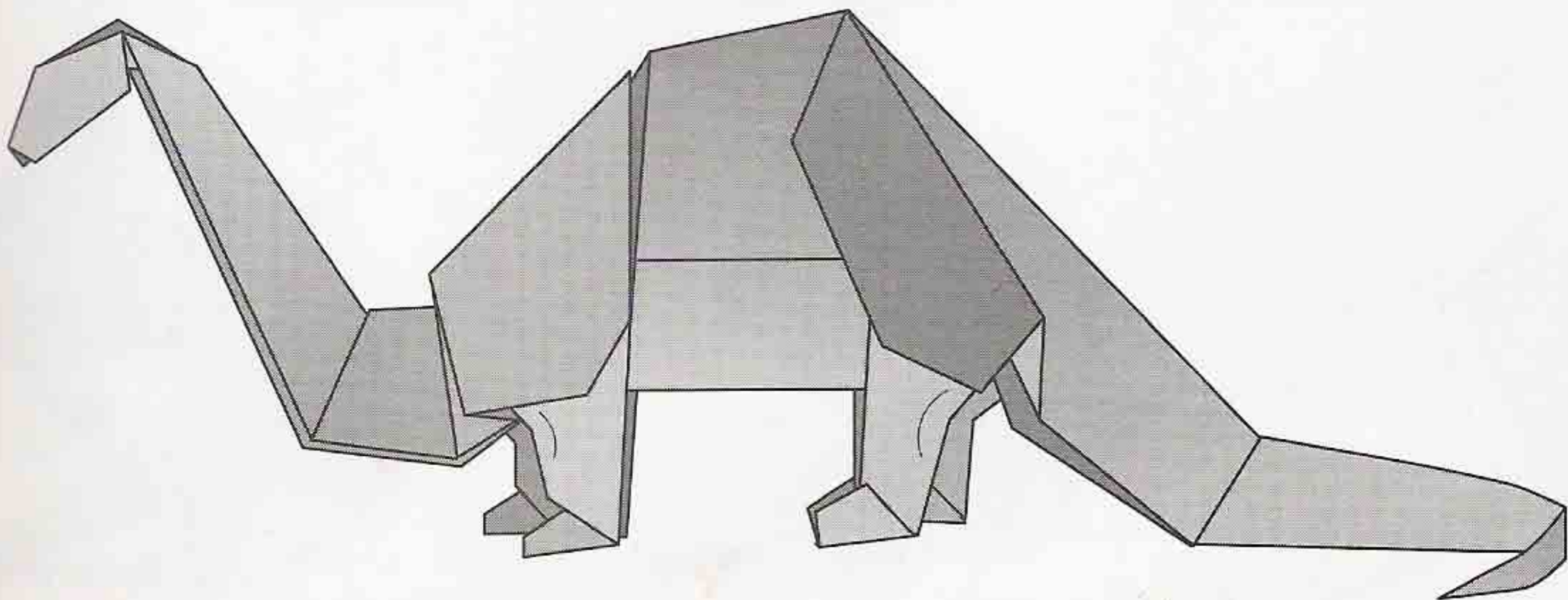

Apatosaurus

Archaeopteryx

are-key-OP-ter-ix

Once thought to be the first bird, this animal was more like a dinosaur than some of the Mesozoic animals that took to the air. It had solid bones, teeth in its beak, and was not able to fly or glide. It ran around the Jurassic forest floor catching insects. It was the size of a crow and was covered with feathers and scales. Archaeopteryx means "ancient wing".

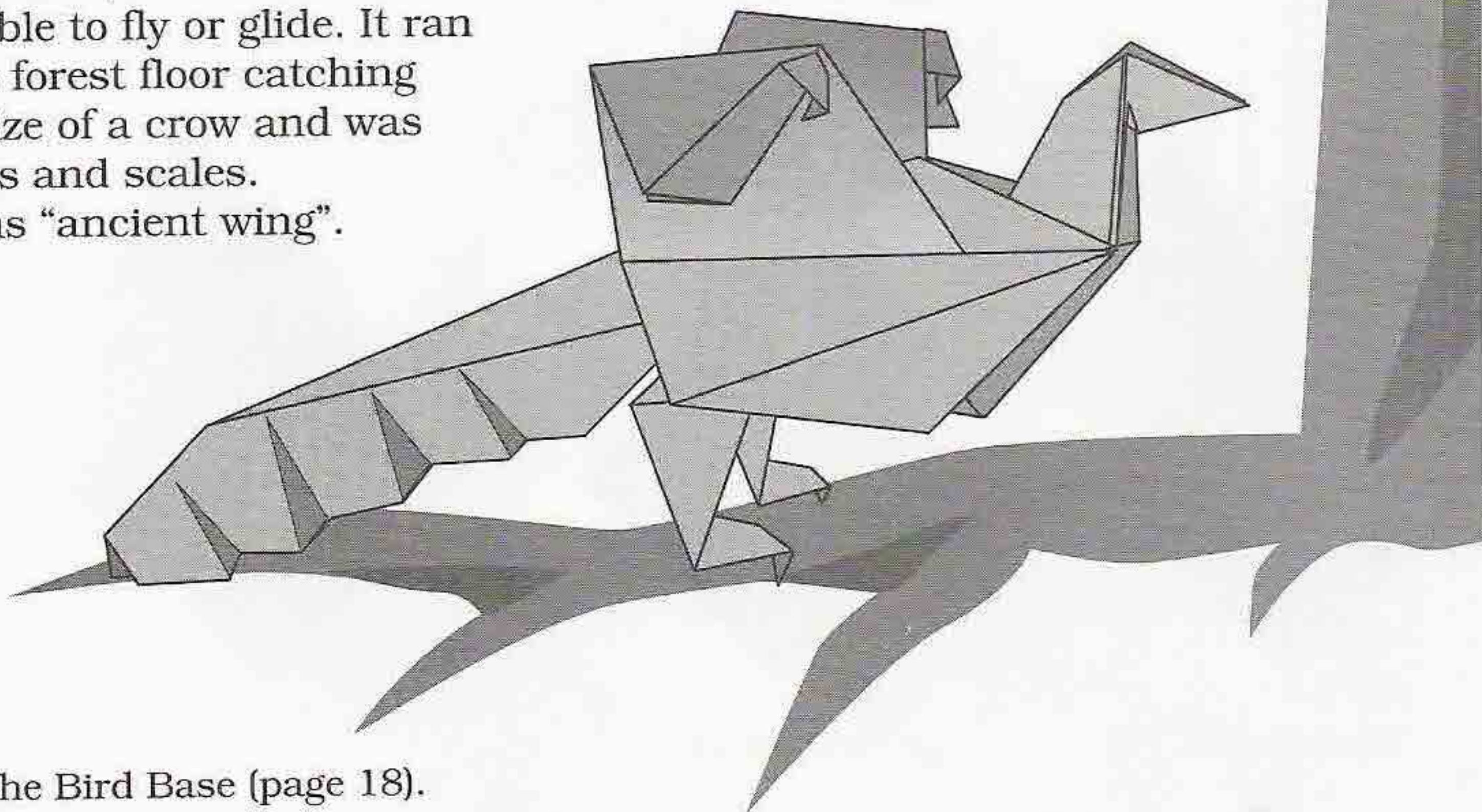

Begin with step 18 of the Bird Base (page 18).

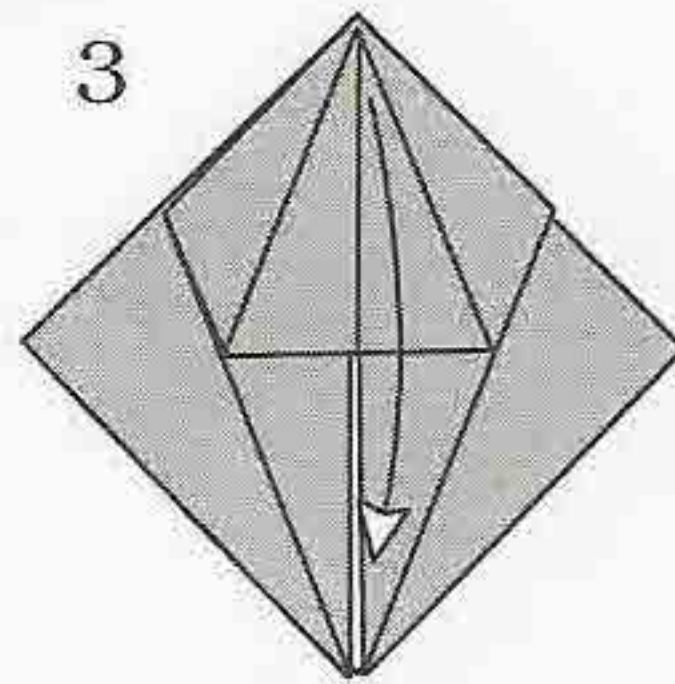
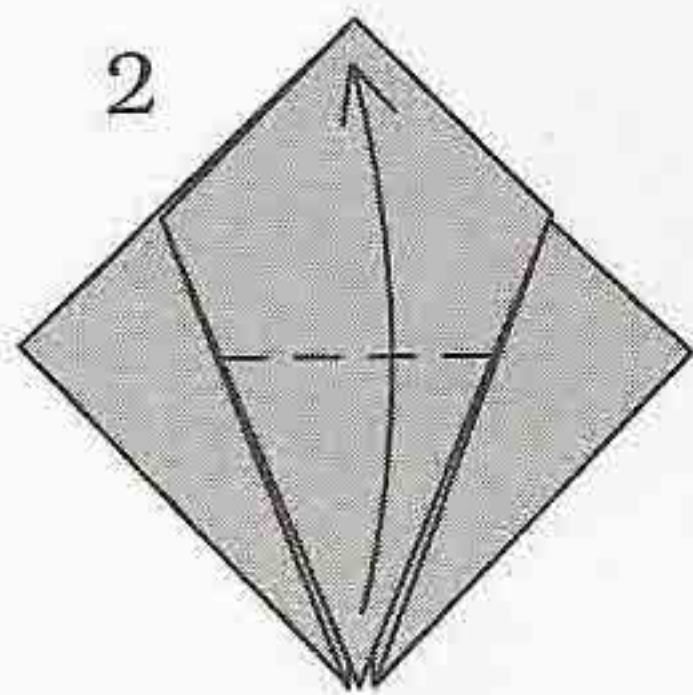
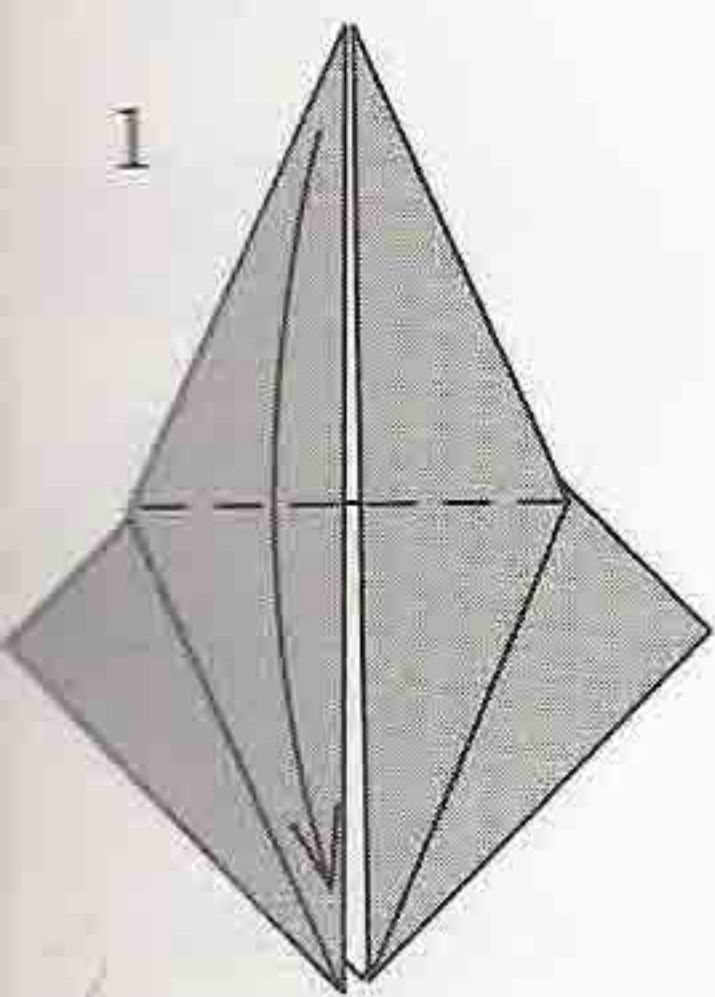

Unfold.

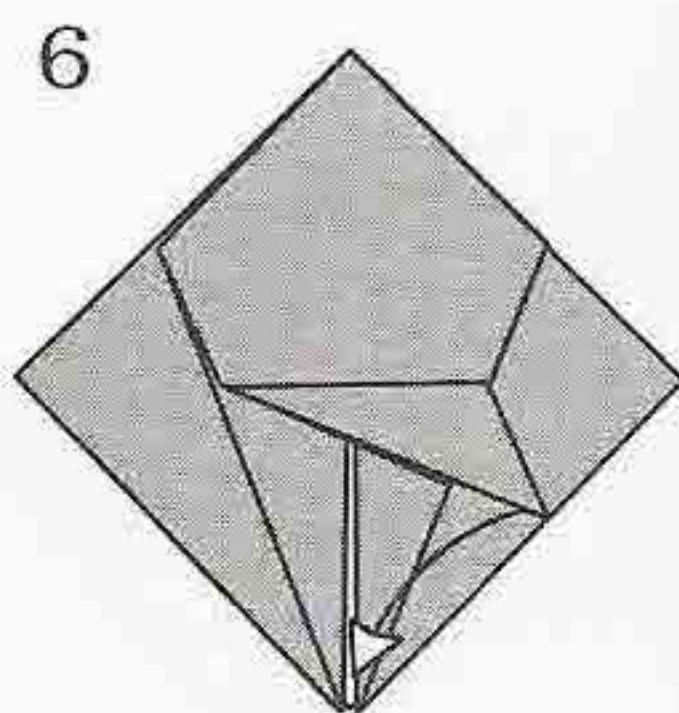
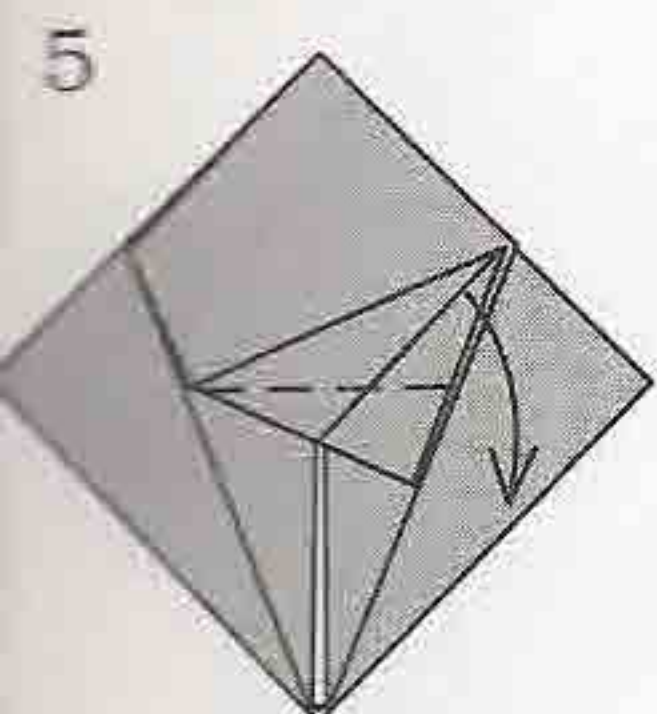
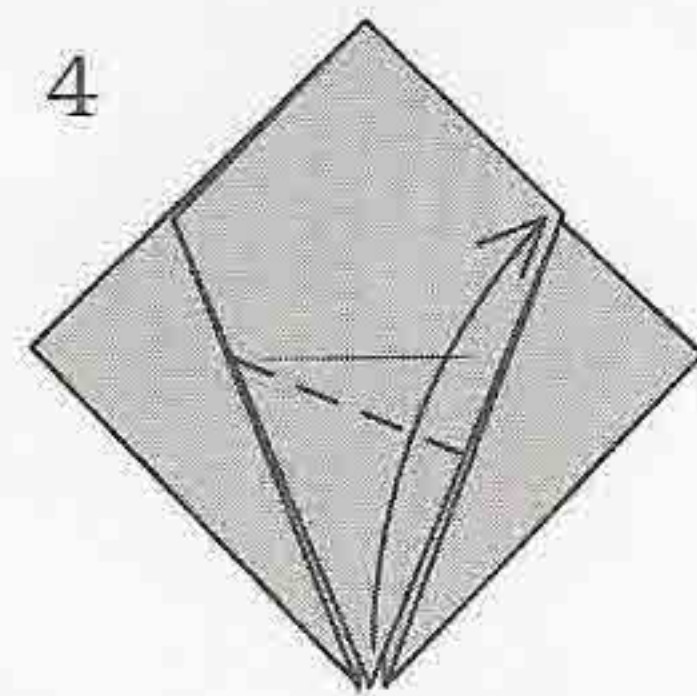

Unfold.

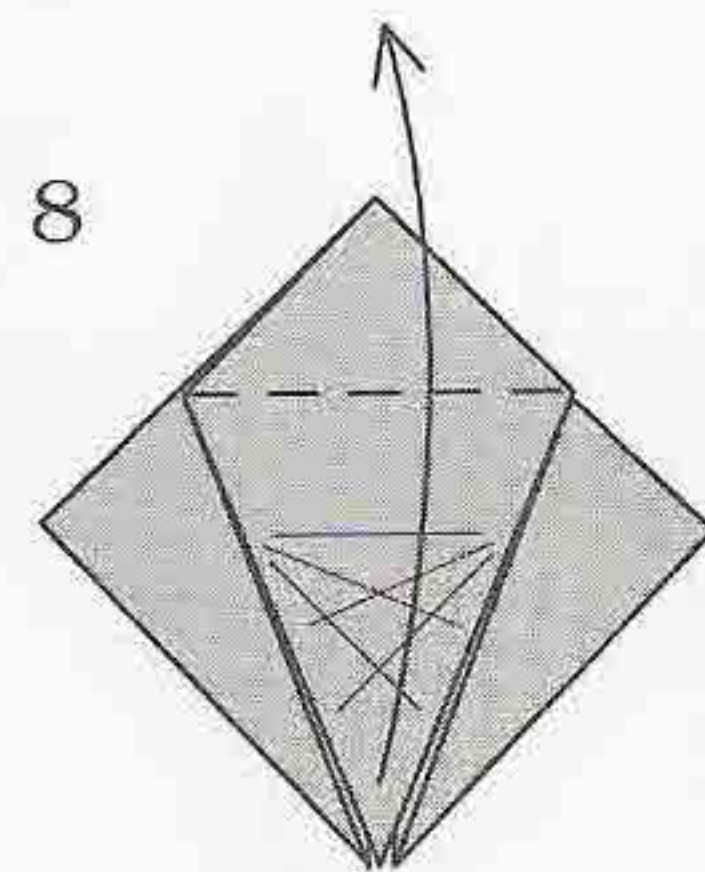
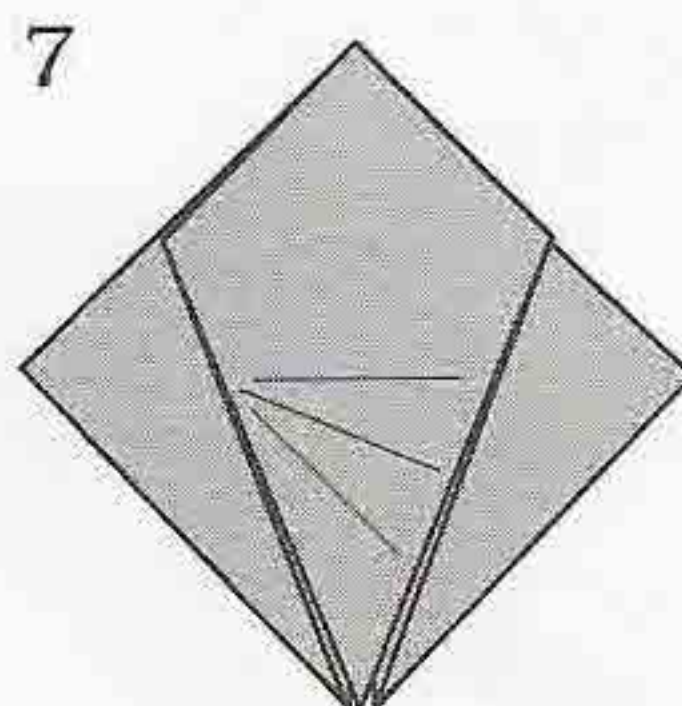

Repeat steps 4-6 in the opposite direction.

9

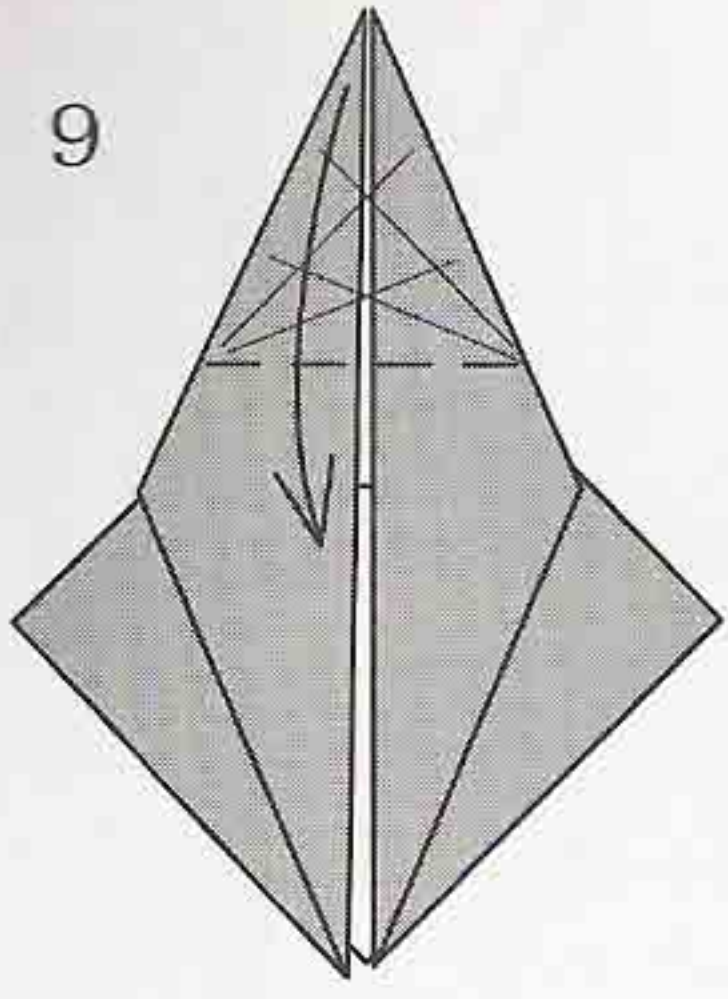

10

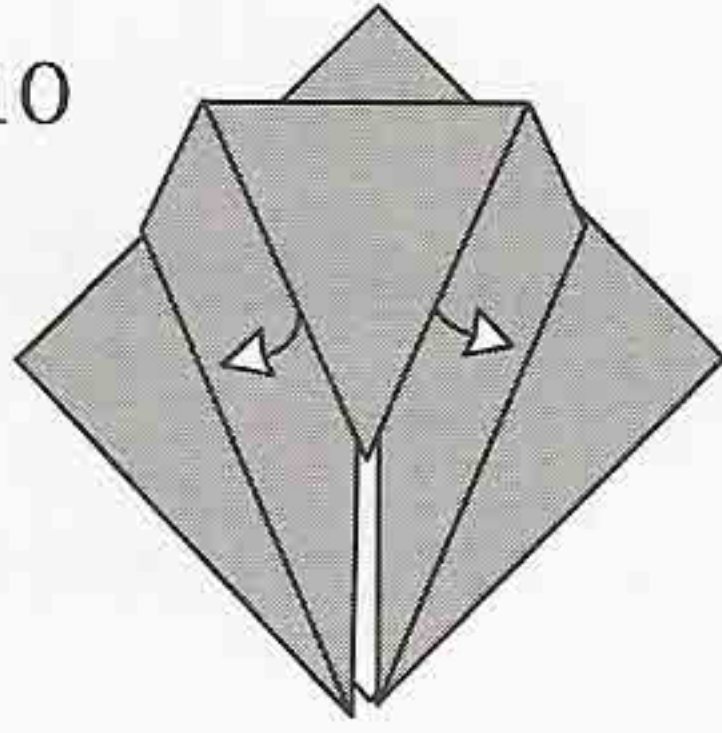

11

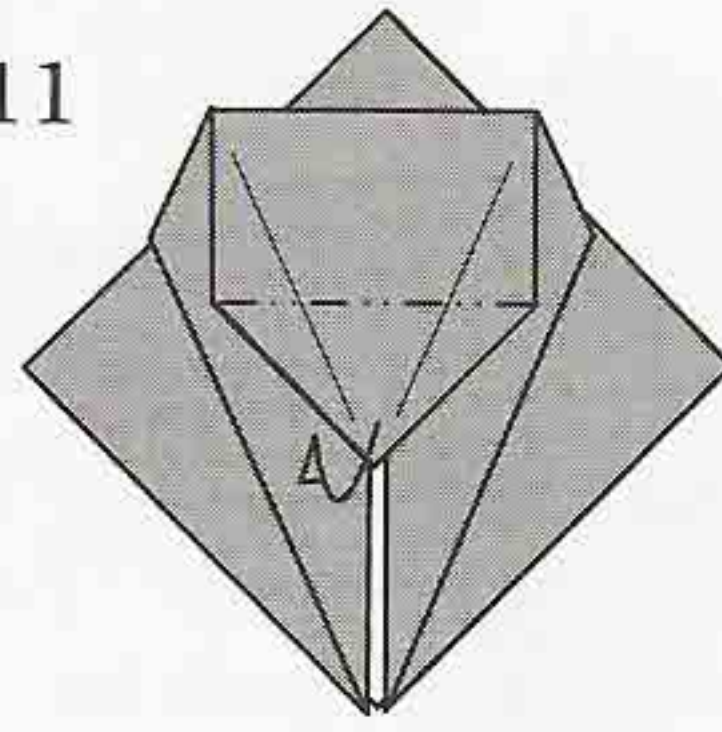

12

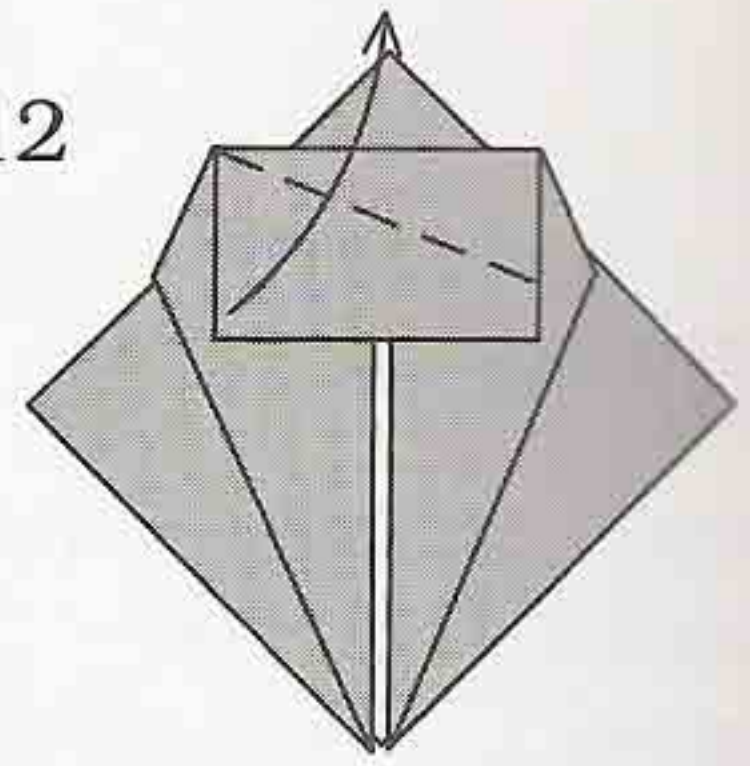

Pull out some paper.

13

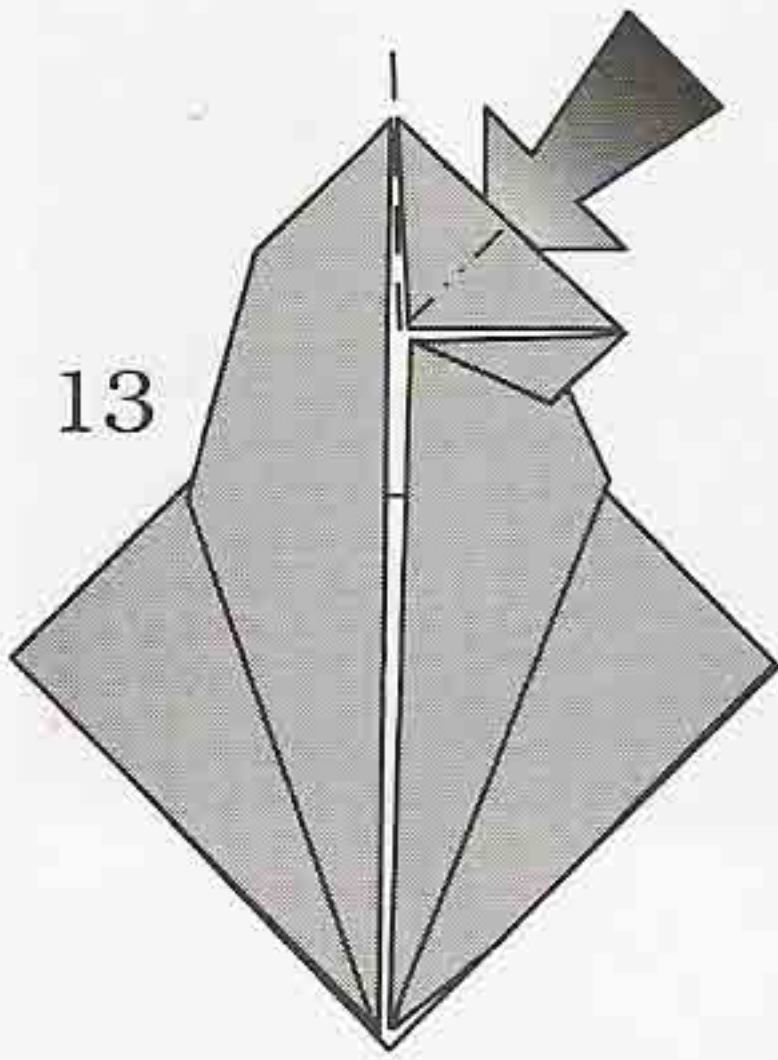

14

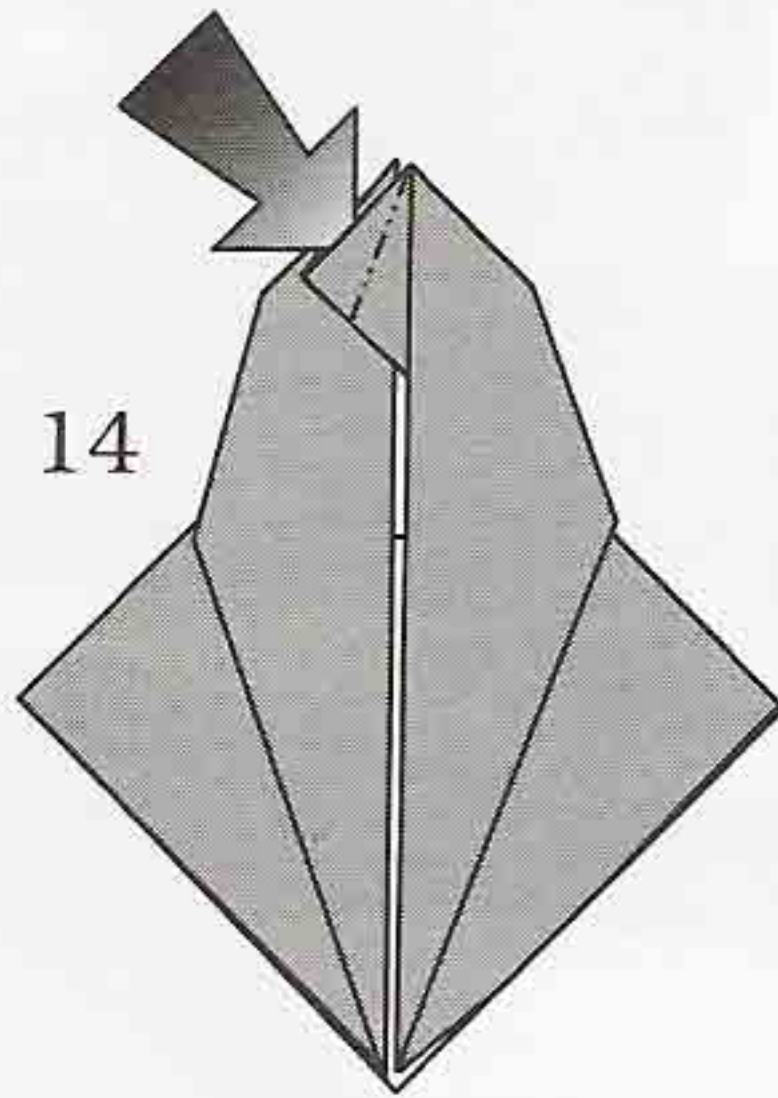

15

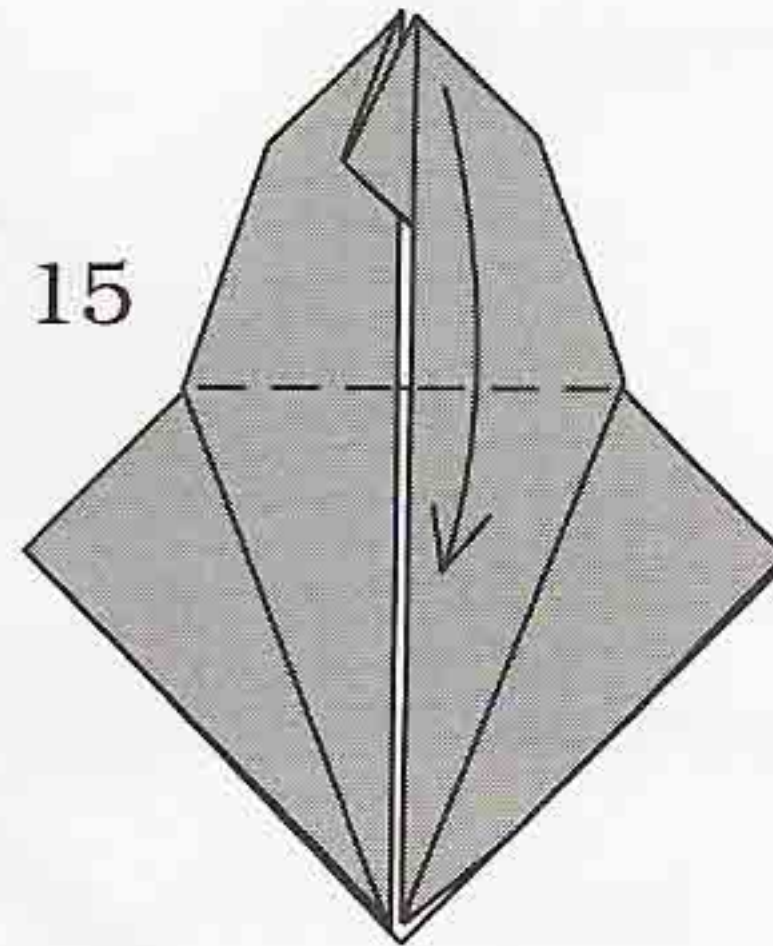

16

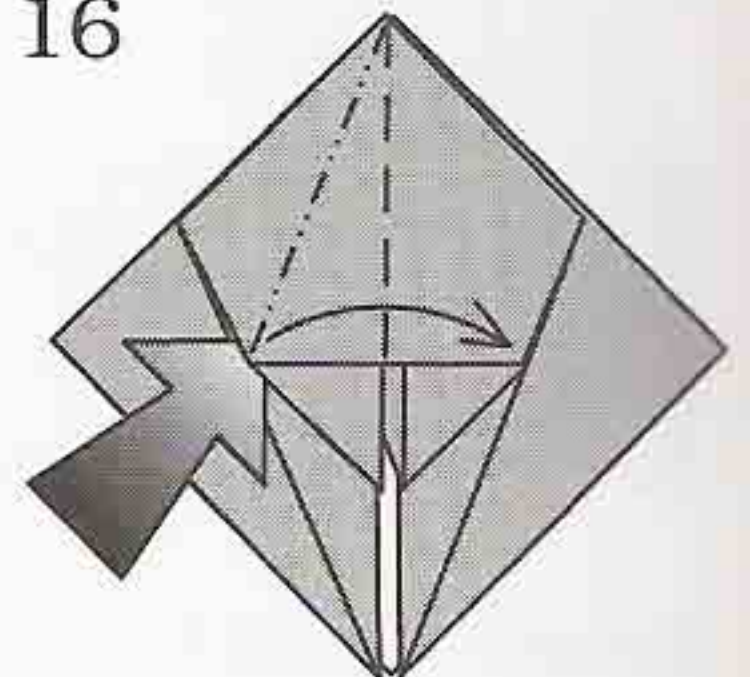

Squash-fold.

Reverse-fold.

Spread-squash-fold.

17

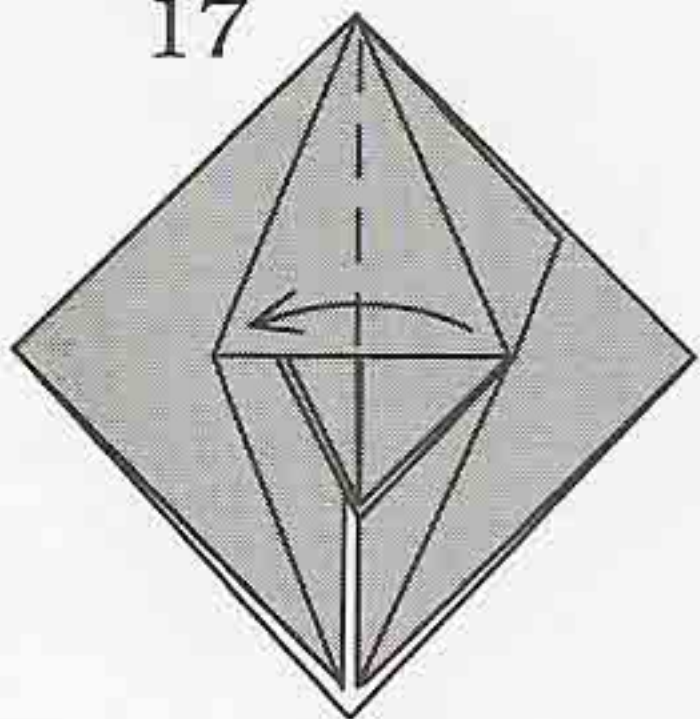

18

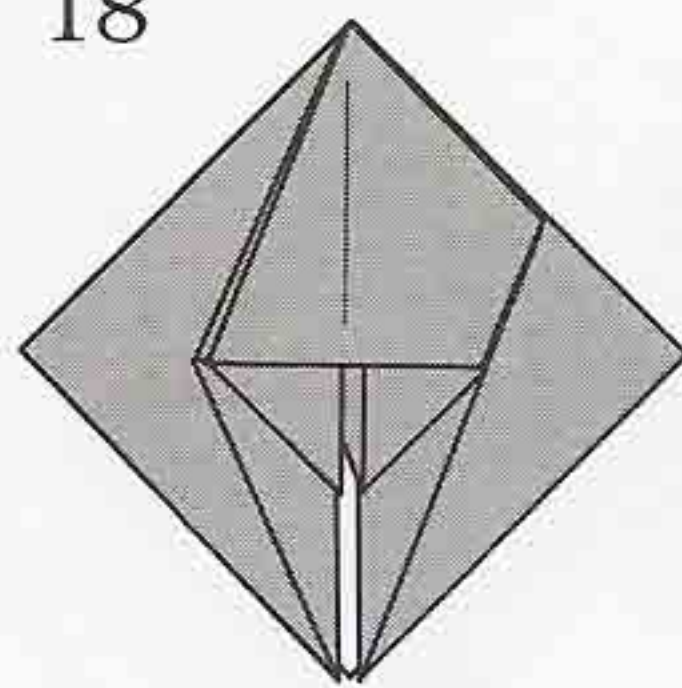

19

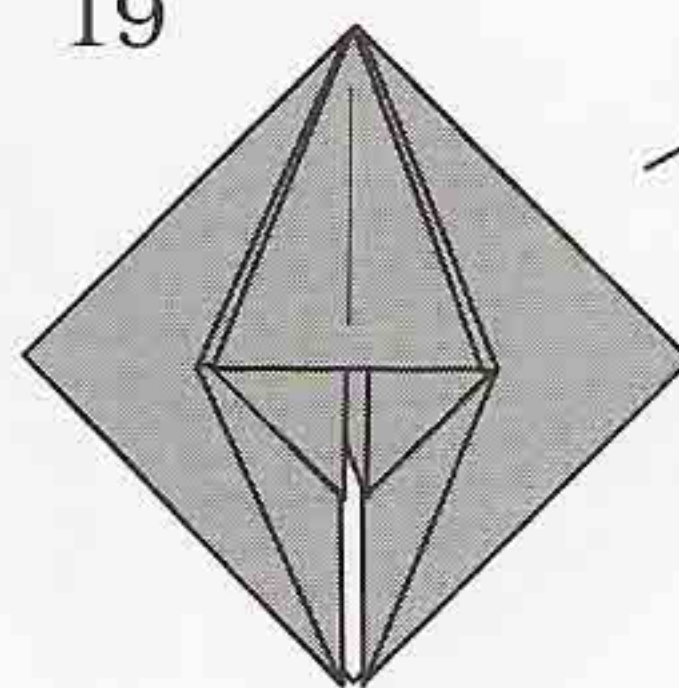

20

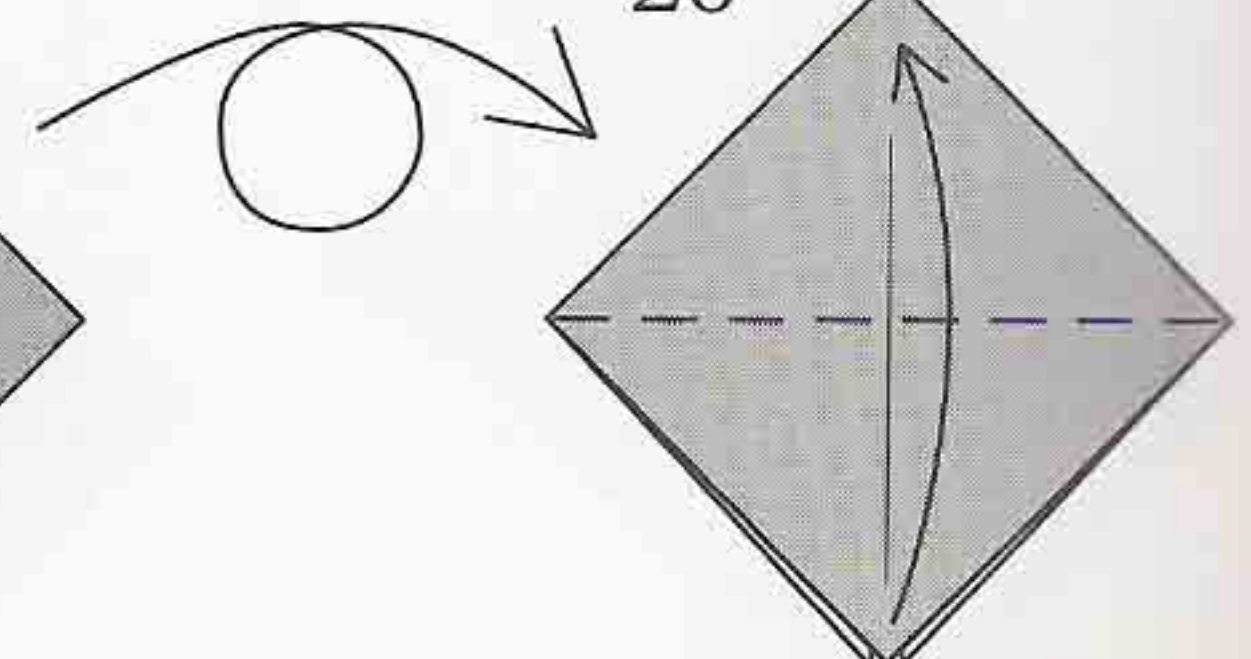

Repeat steps 16-17
on the right.

21

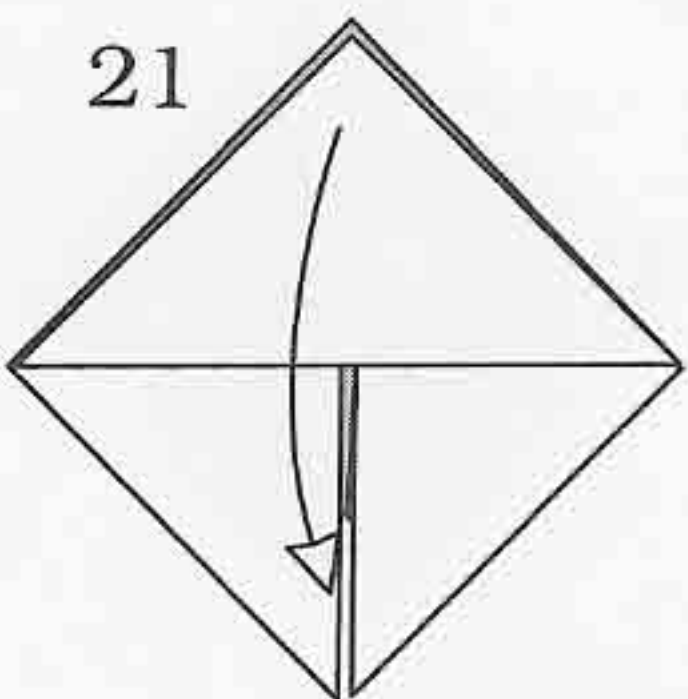

Unfold.

22

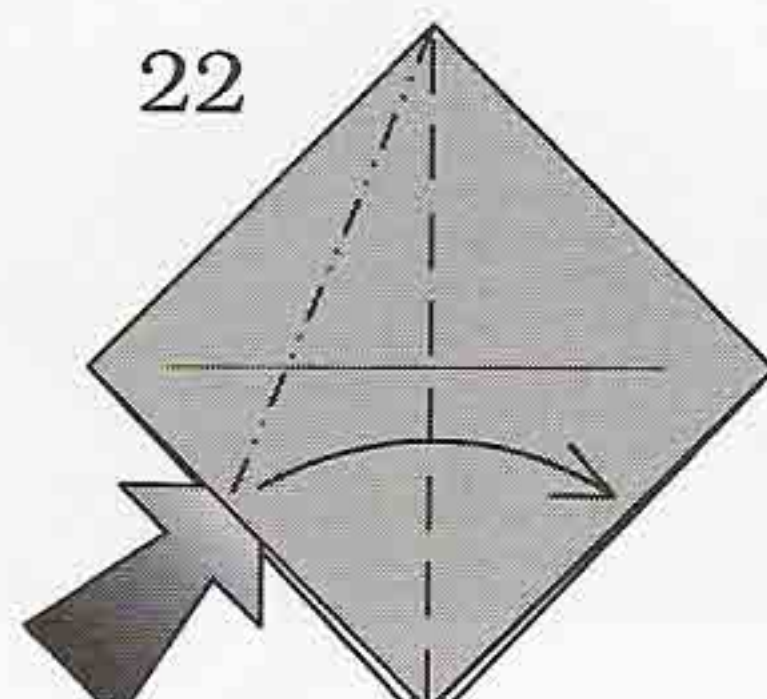

Squash-fold.

23

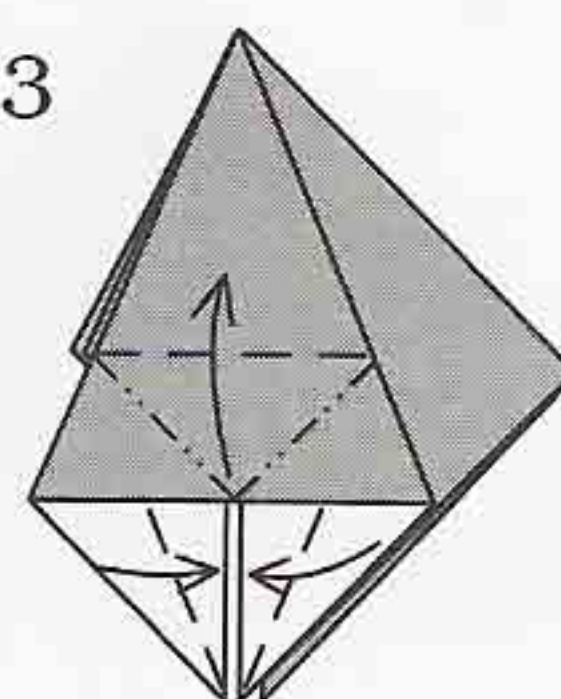

Petal-fold.

24

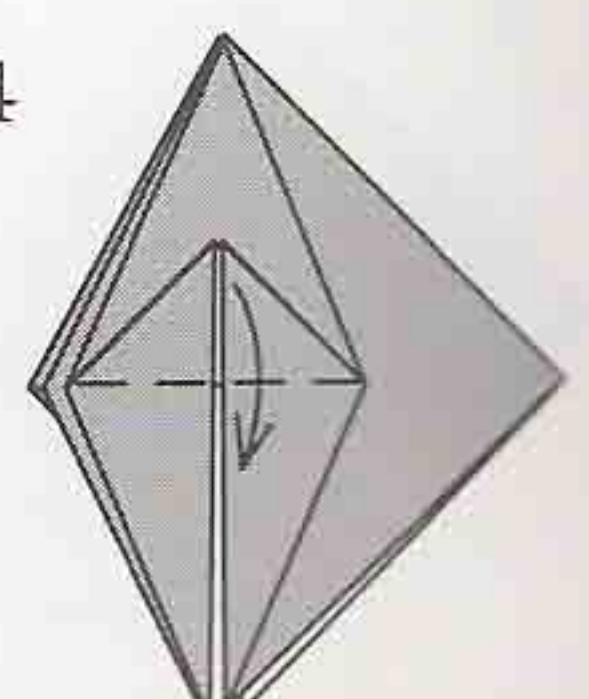

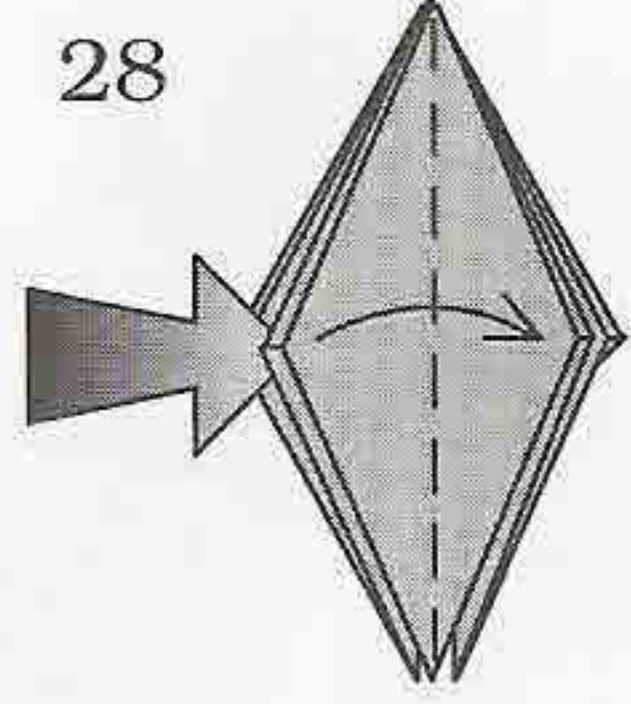
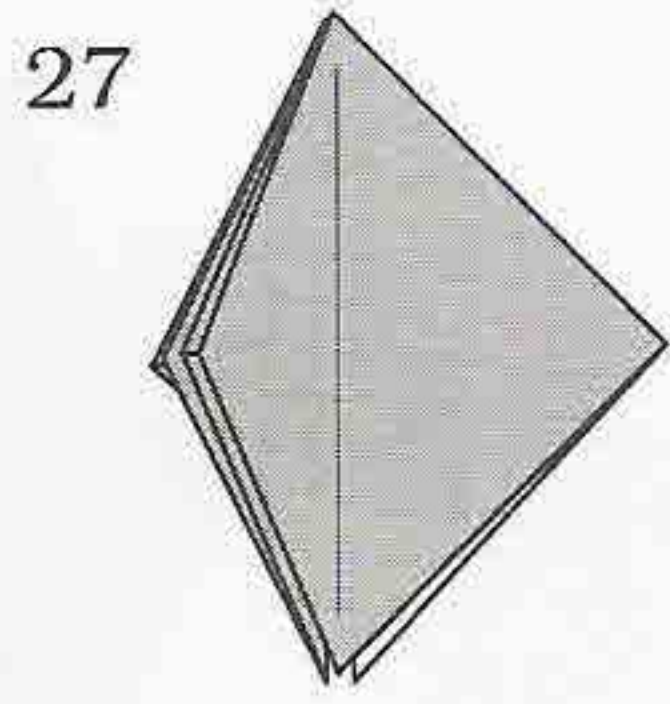
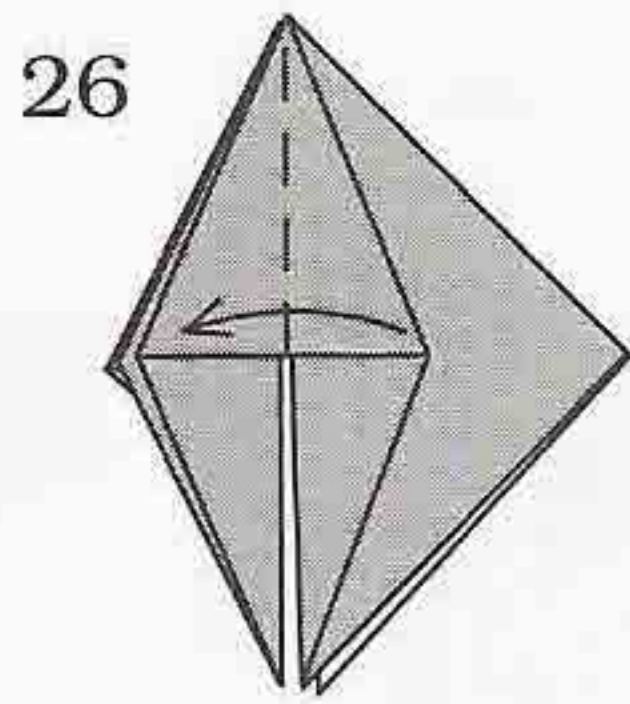
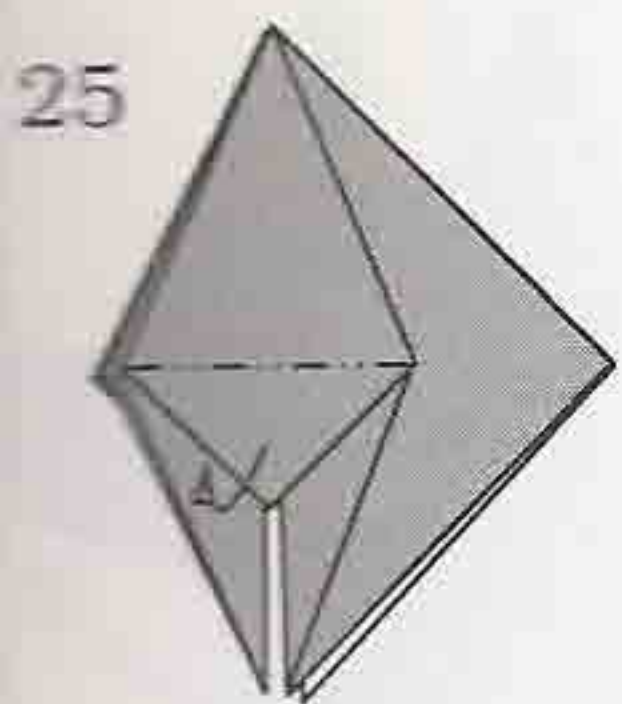

Repeat steps 22-26 on the right.

Fold two layers to the right.

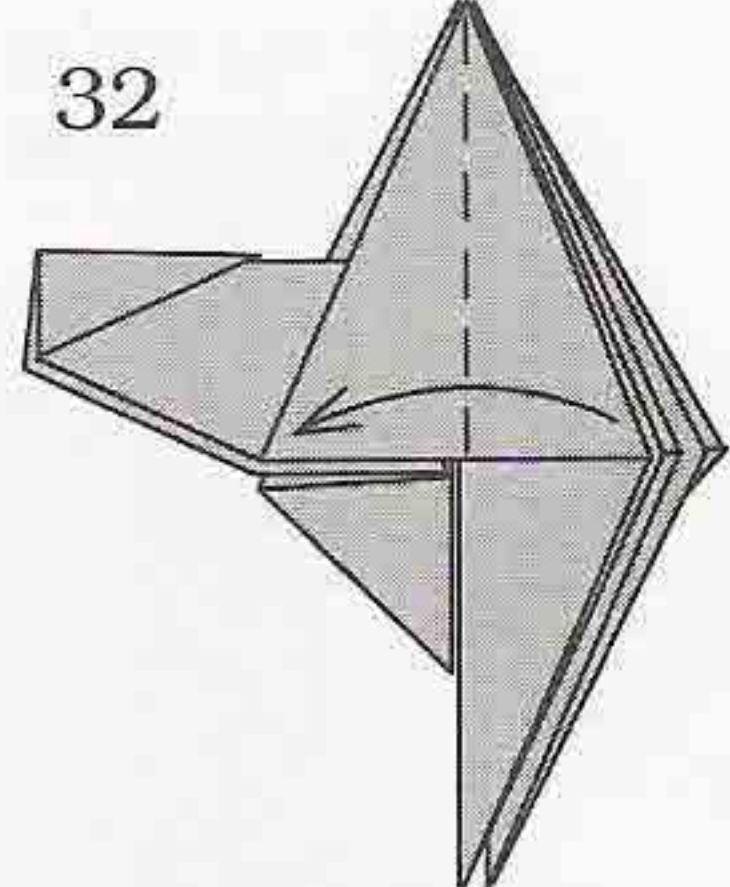
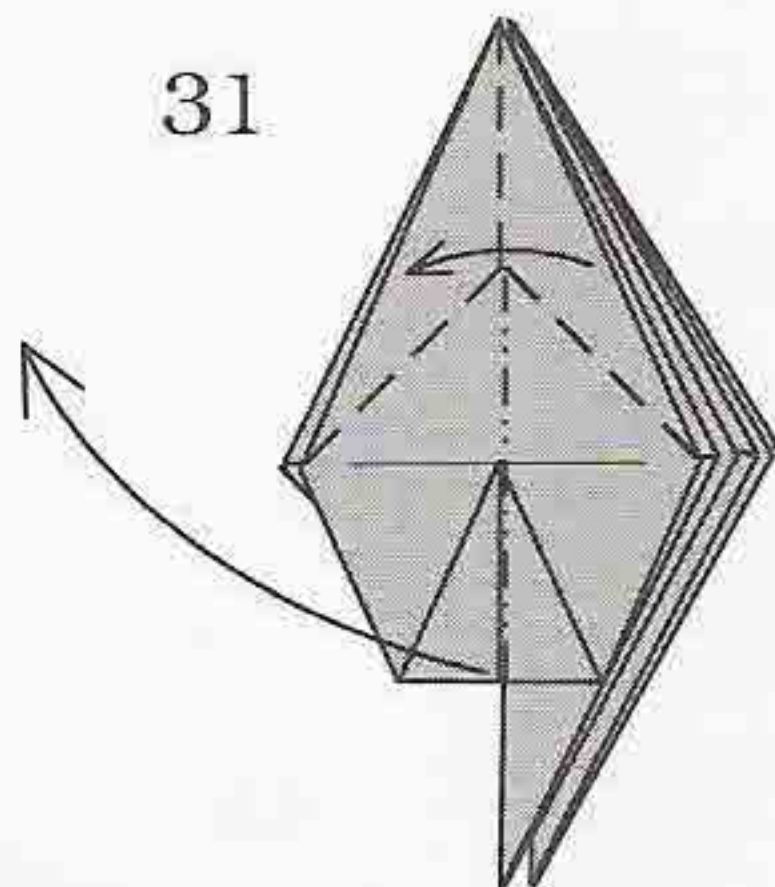
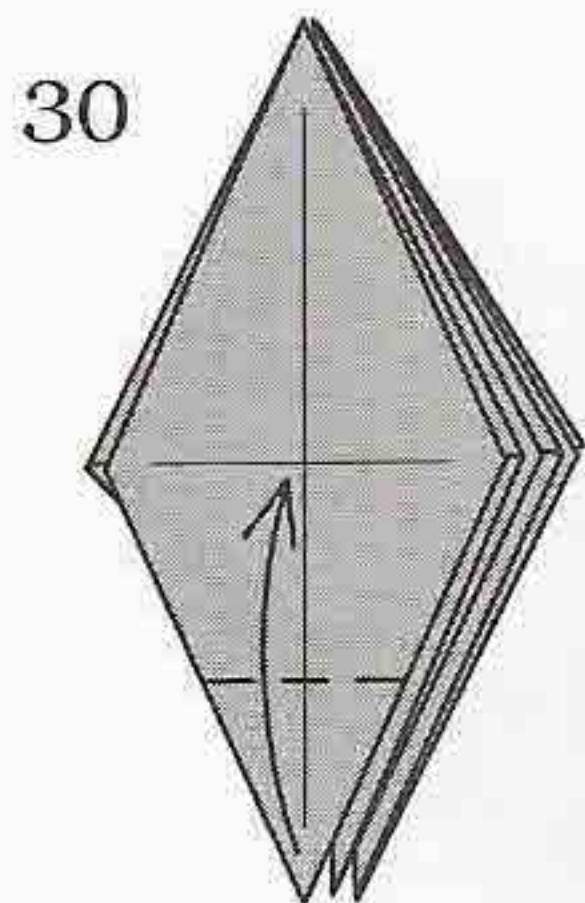
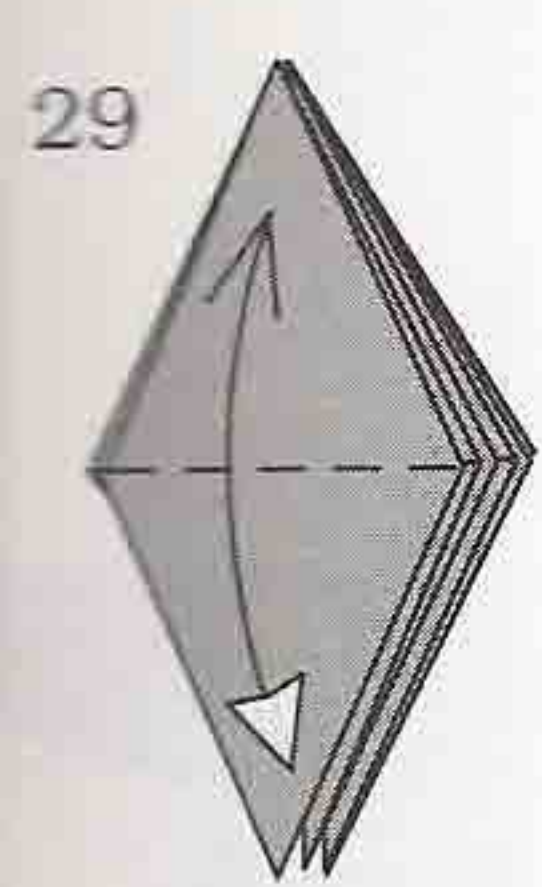

Fold up and unfold.

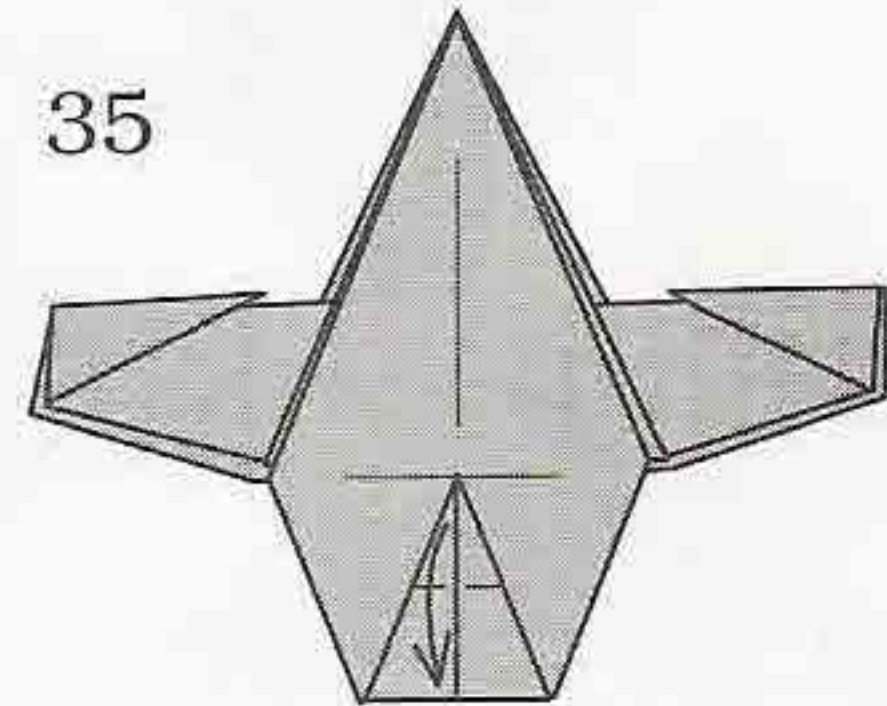
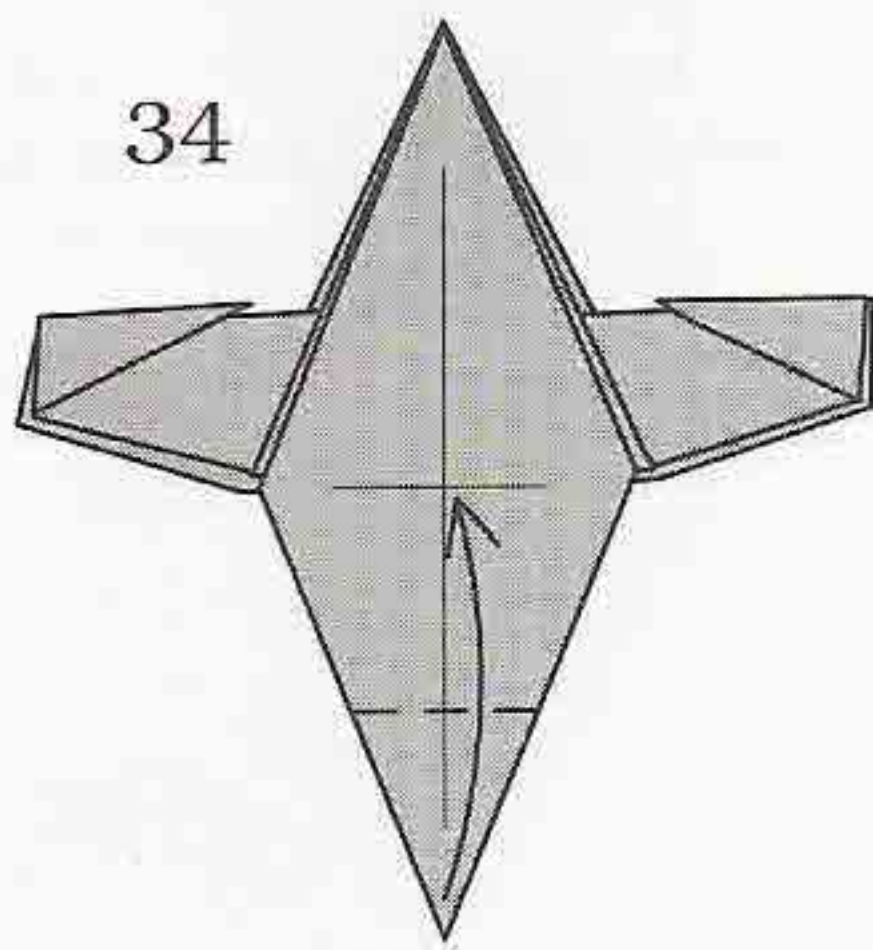
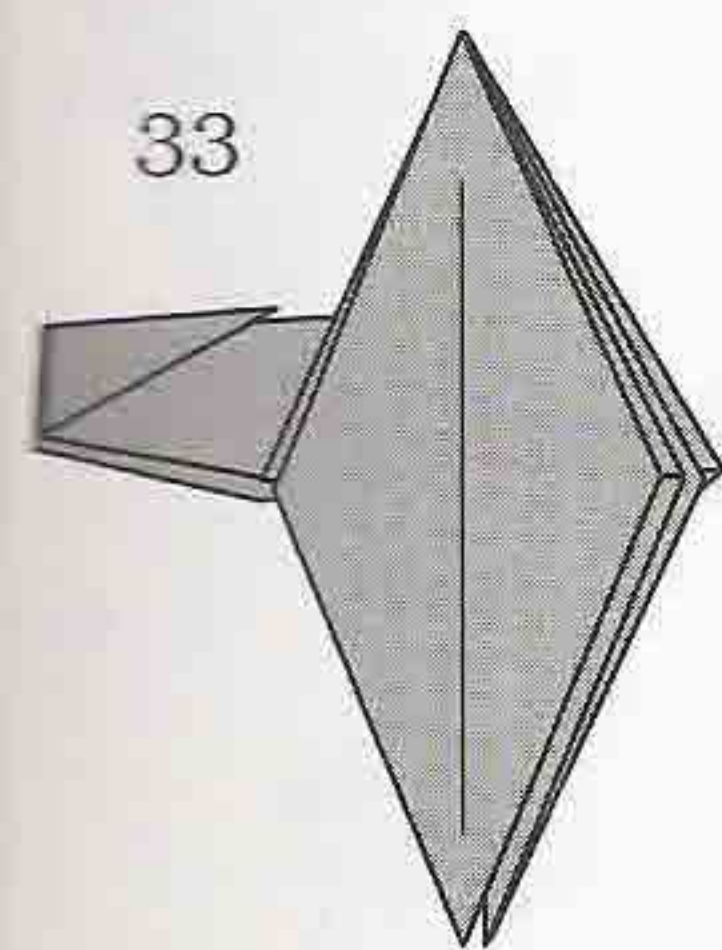

Repeat steps 28-32 on the right.

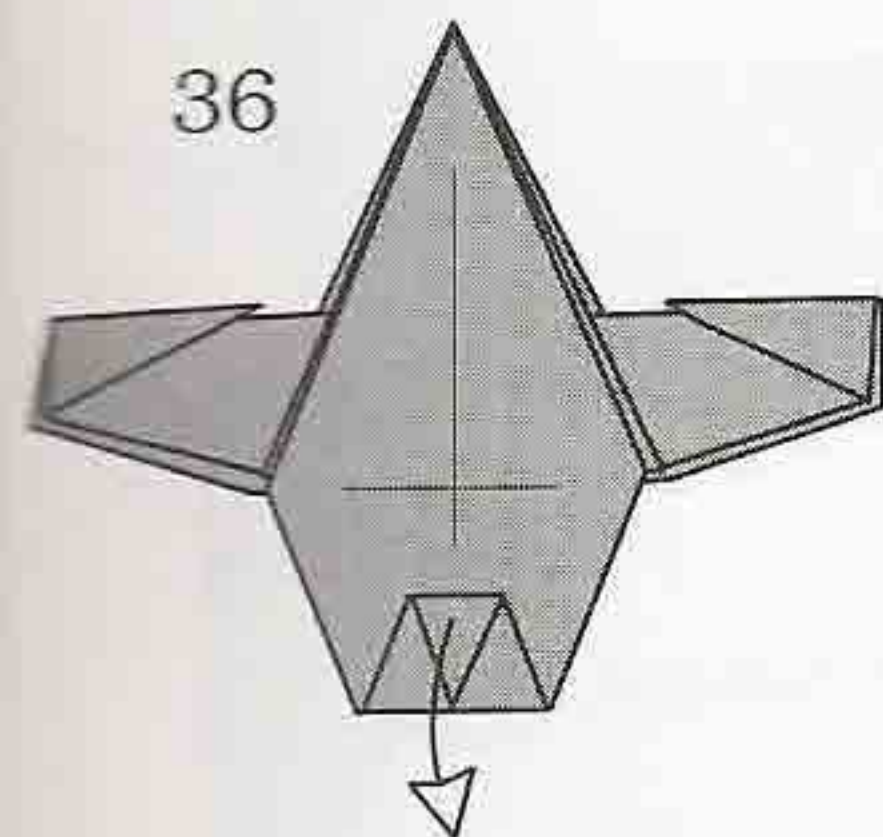

Unfold.

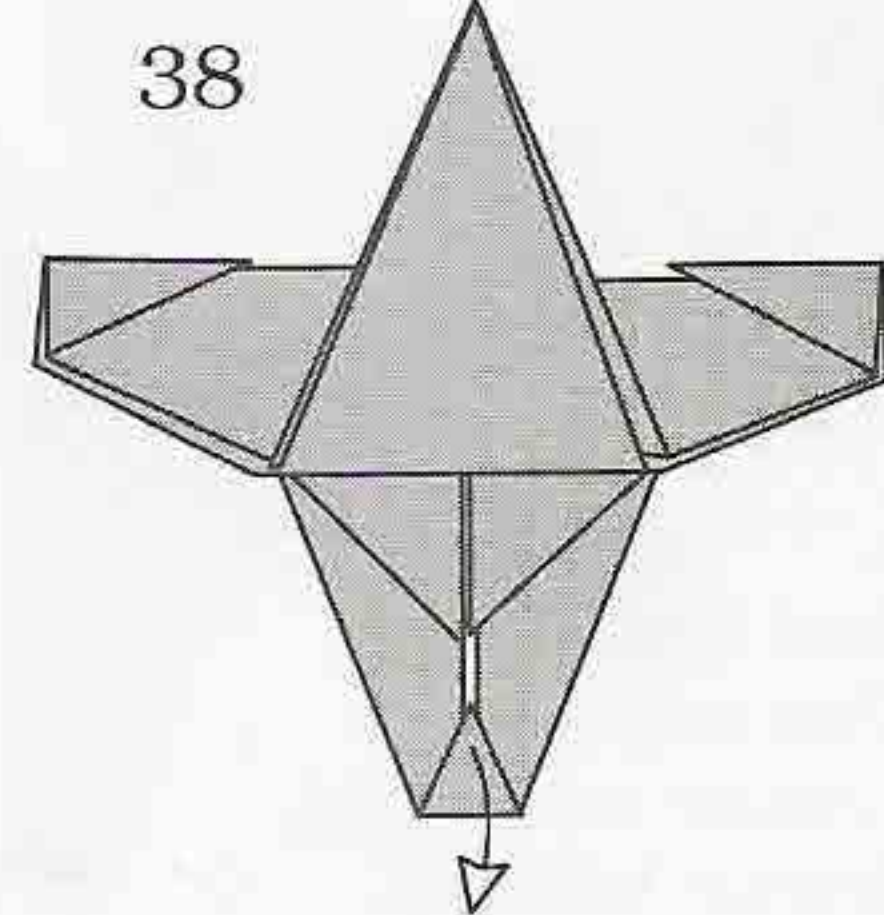
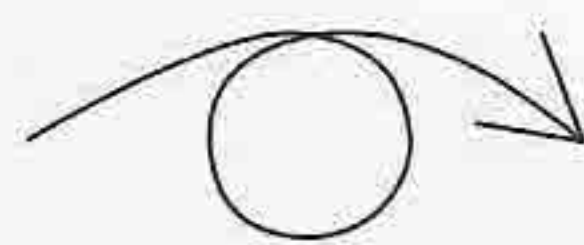
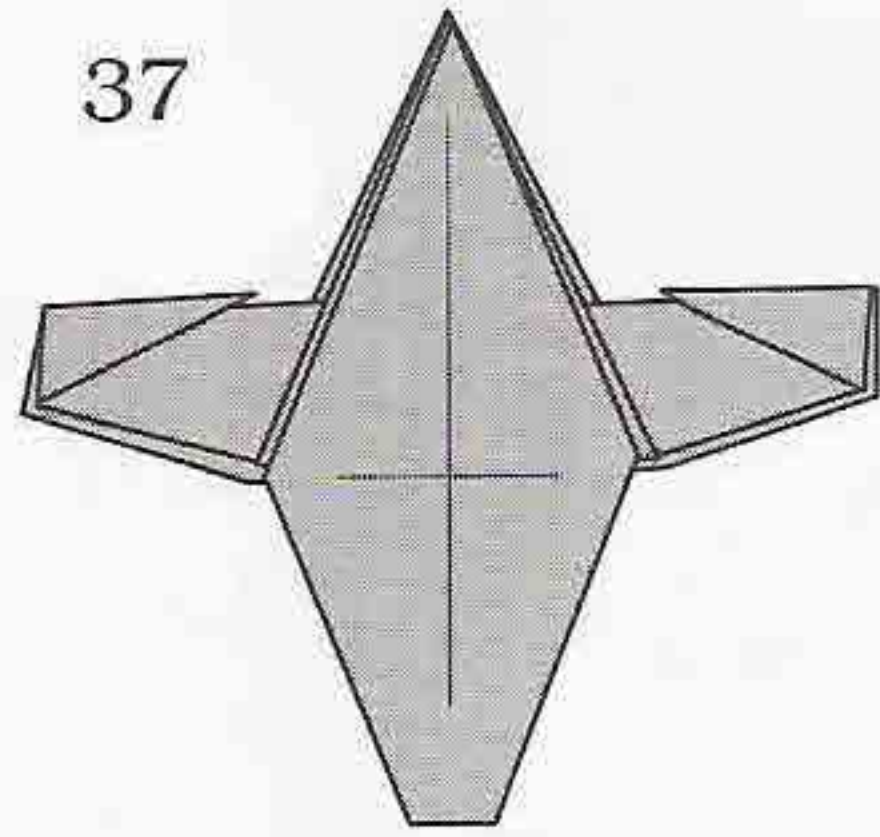

Unfold.

39

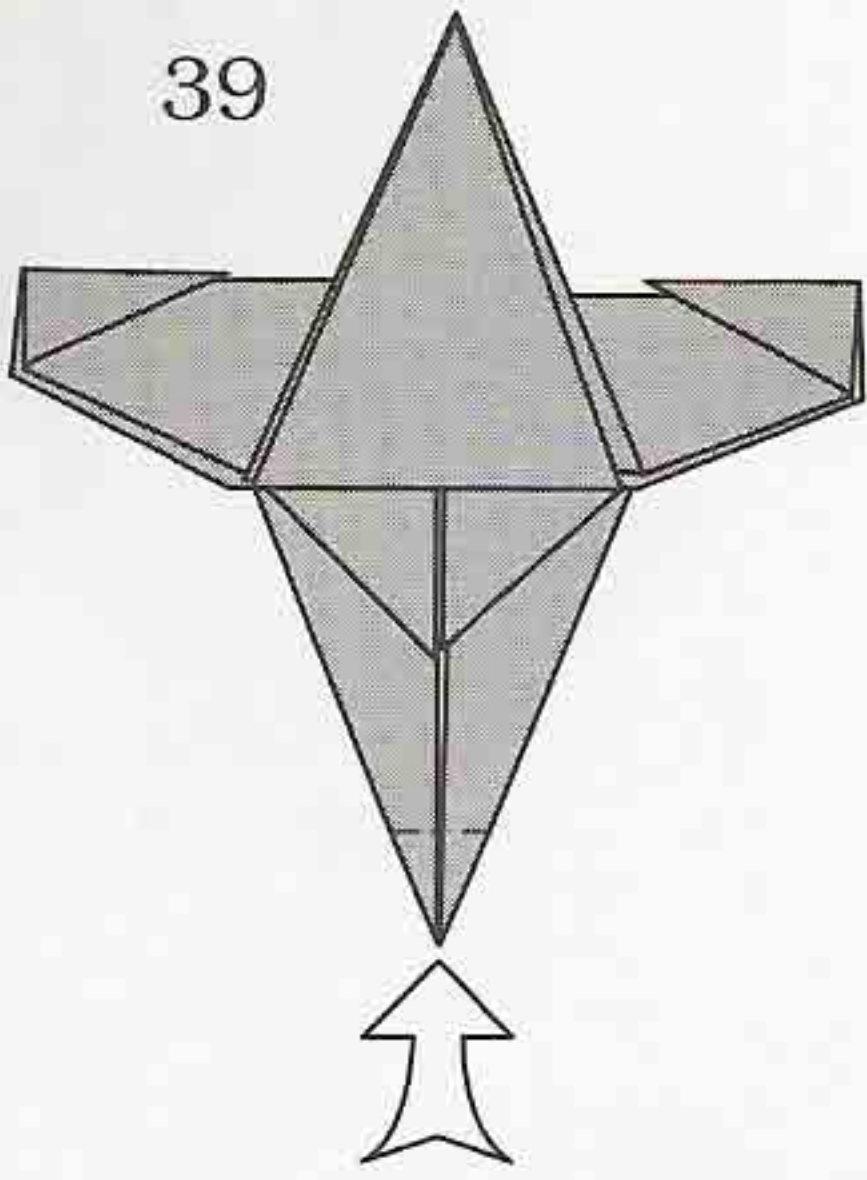

Fold the tip of the tail inside.

40

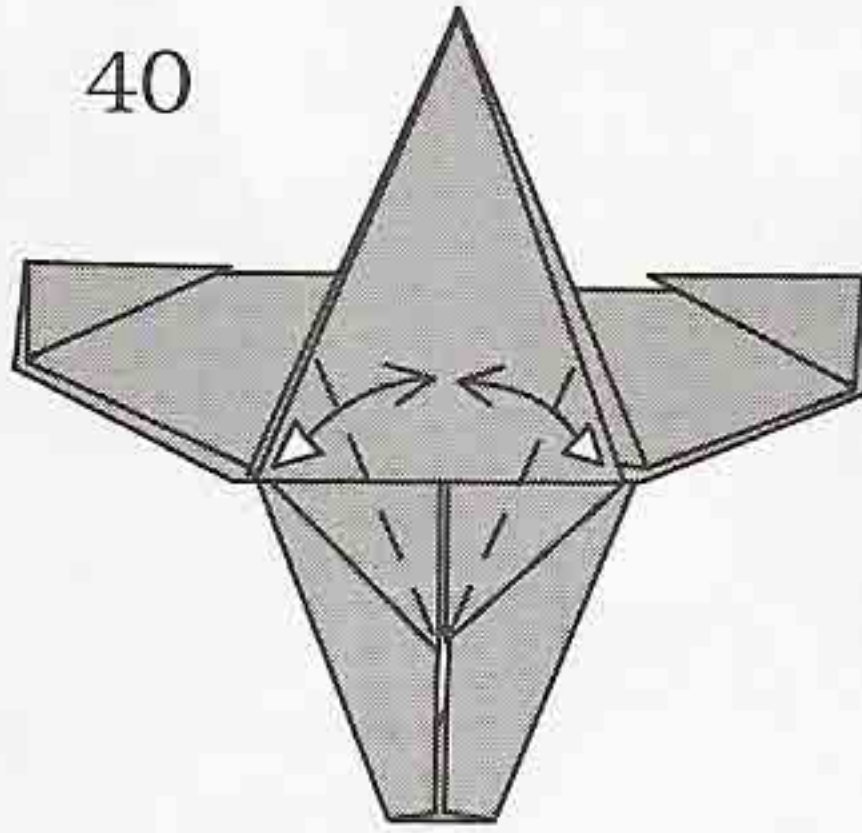

Kite-fold and unfold.

41

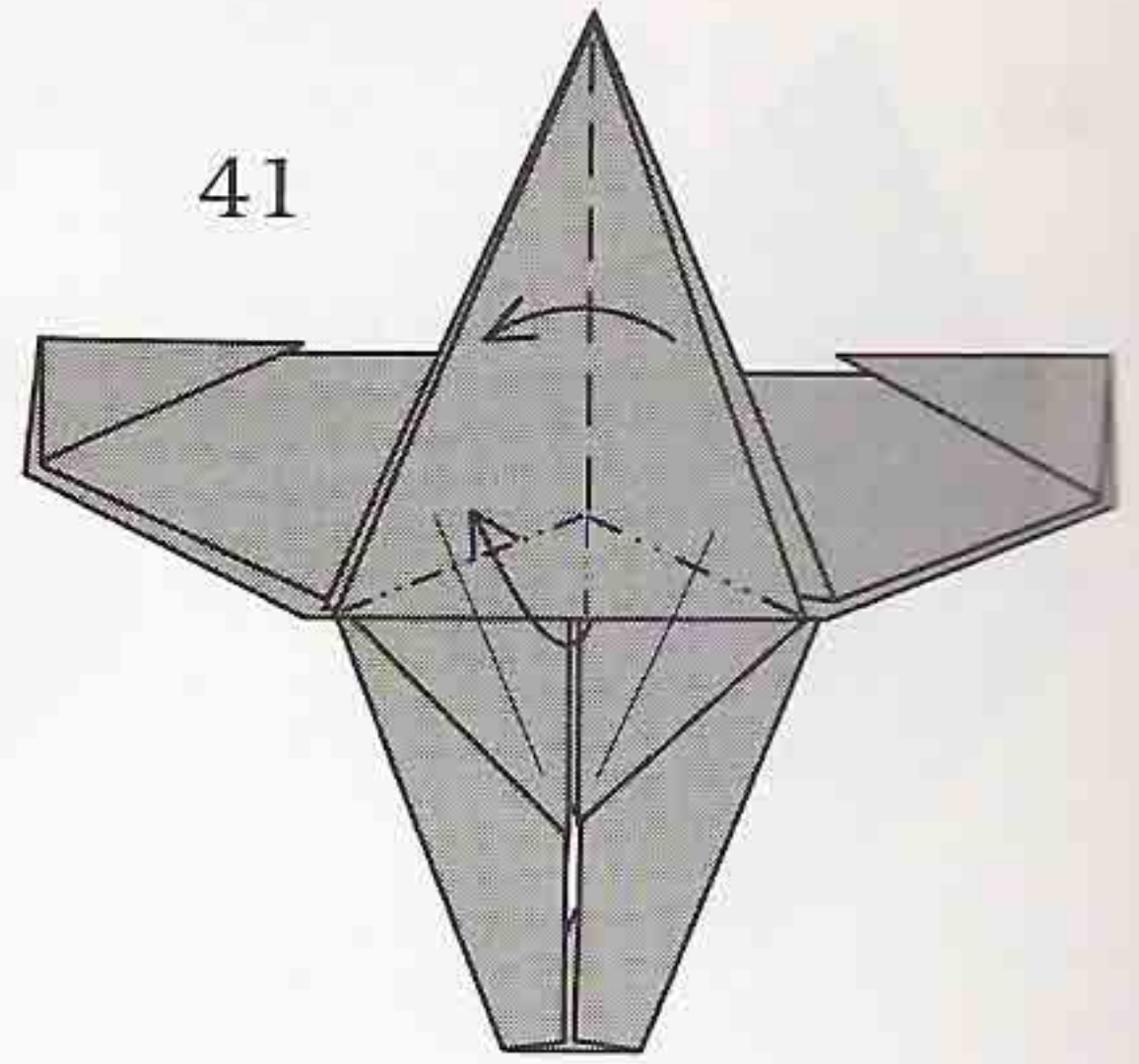

42

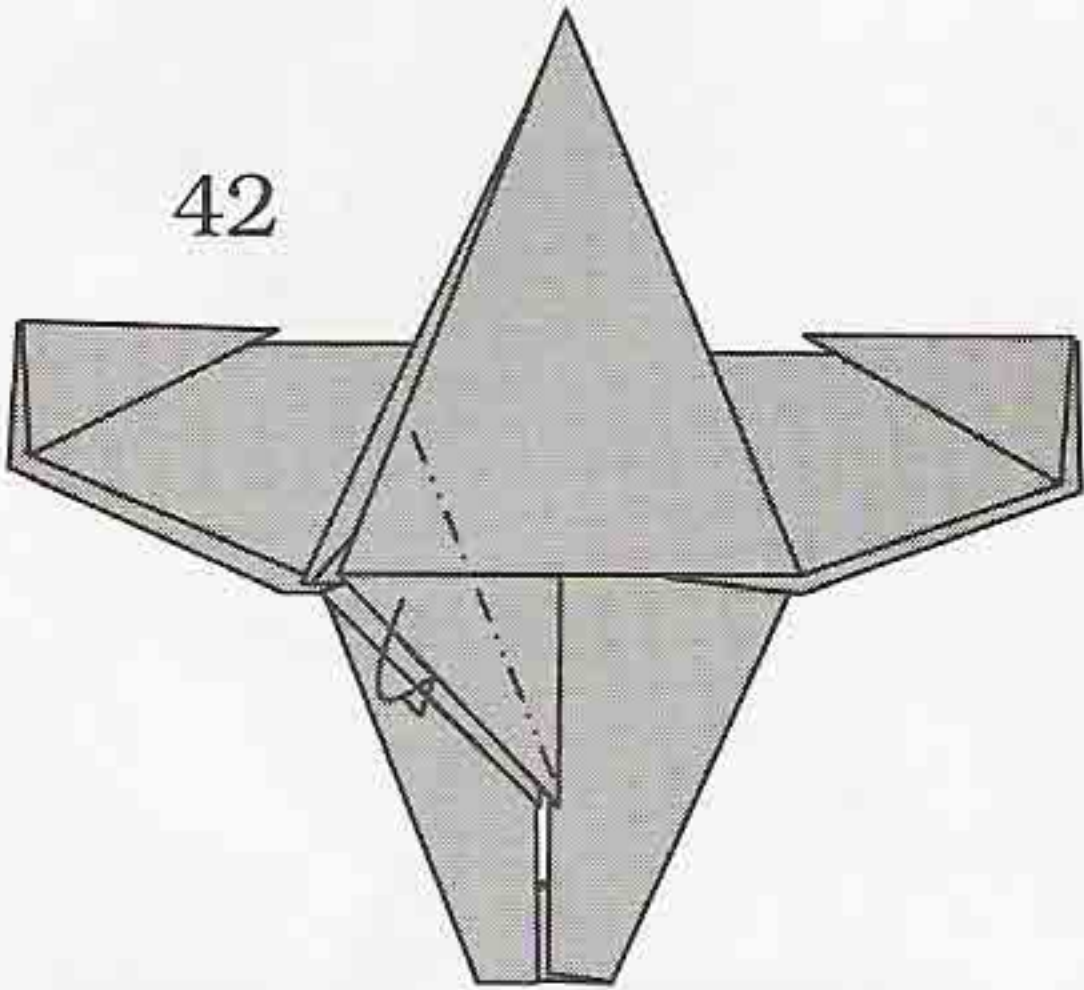

Repeat behind.

43

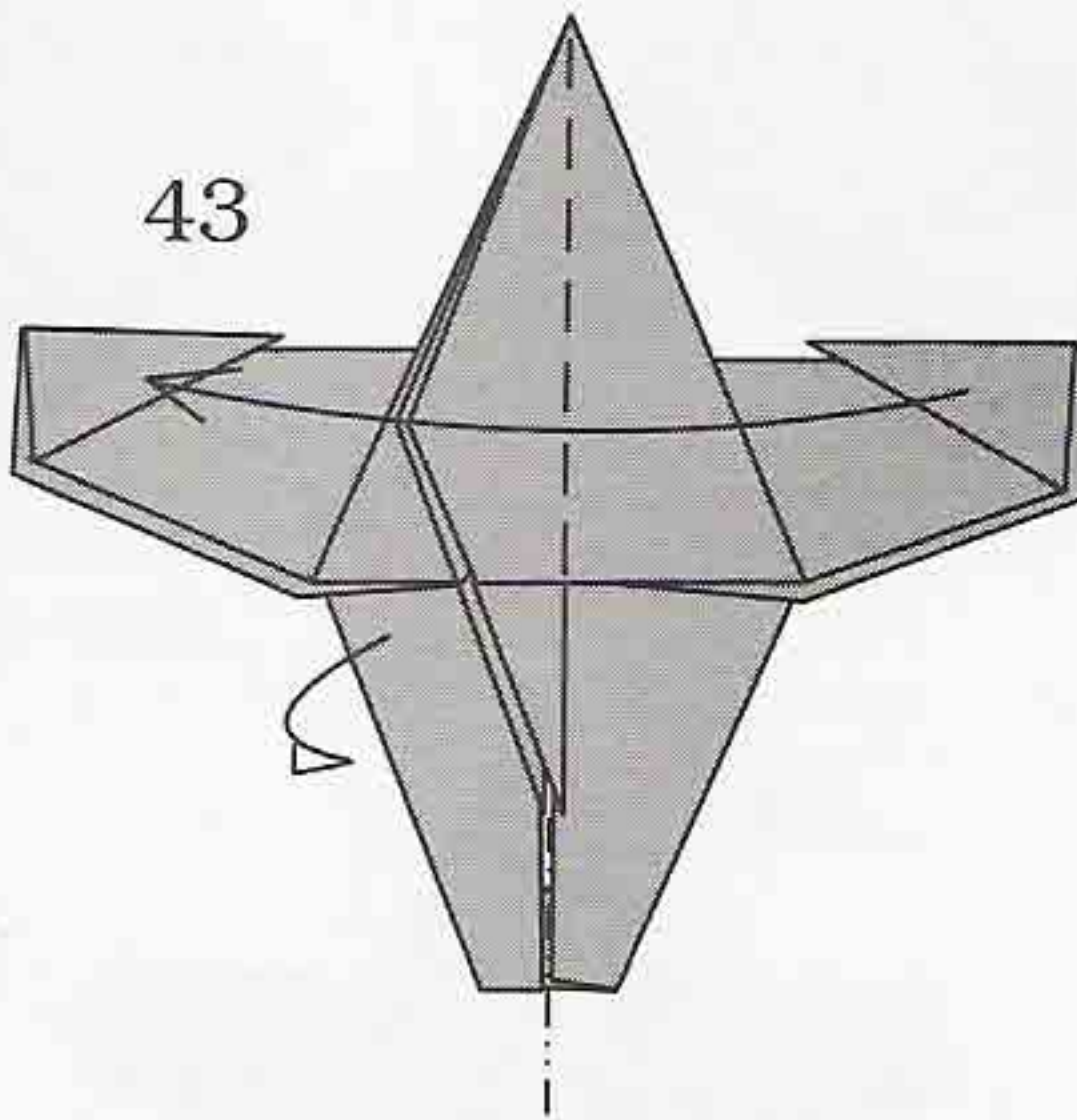

44

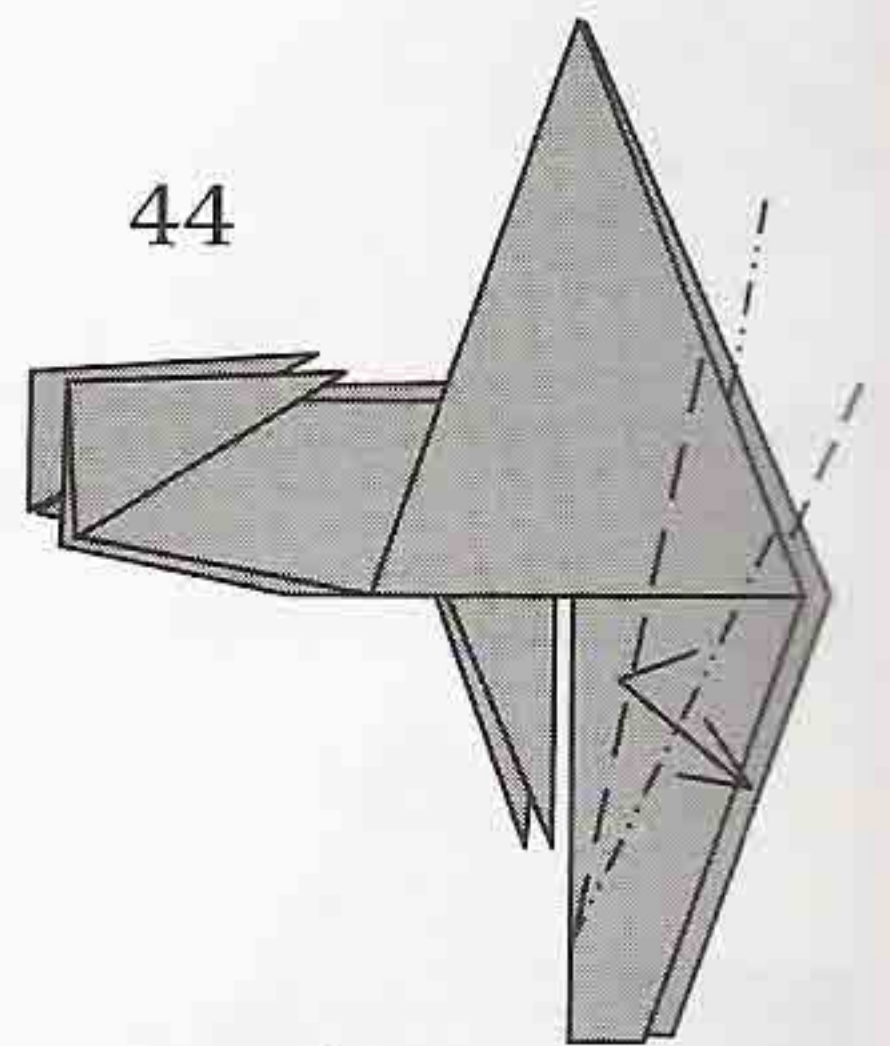

Crimp-fold.

45

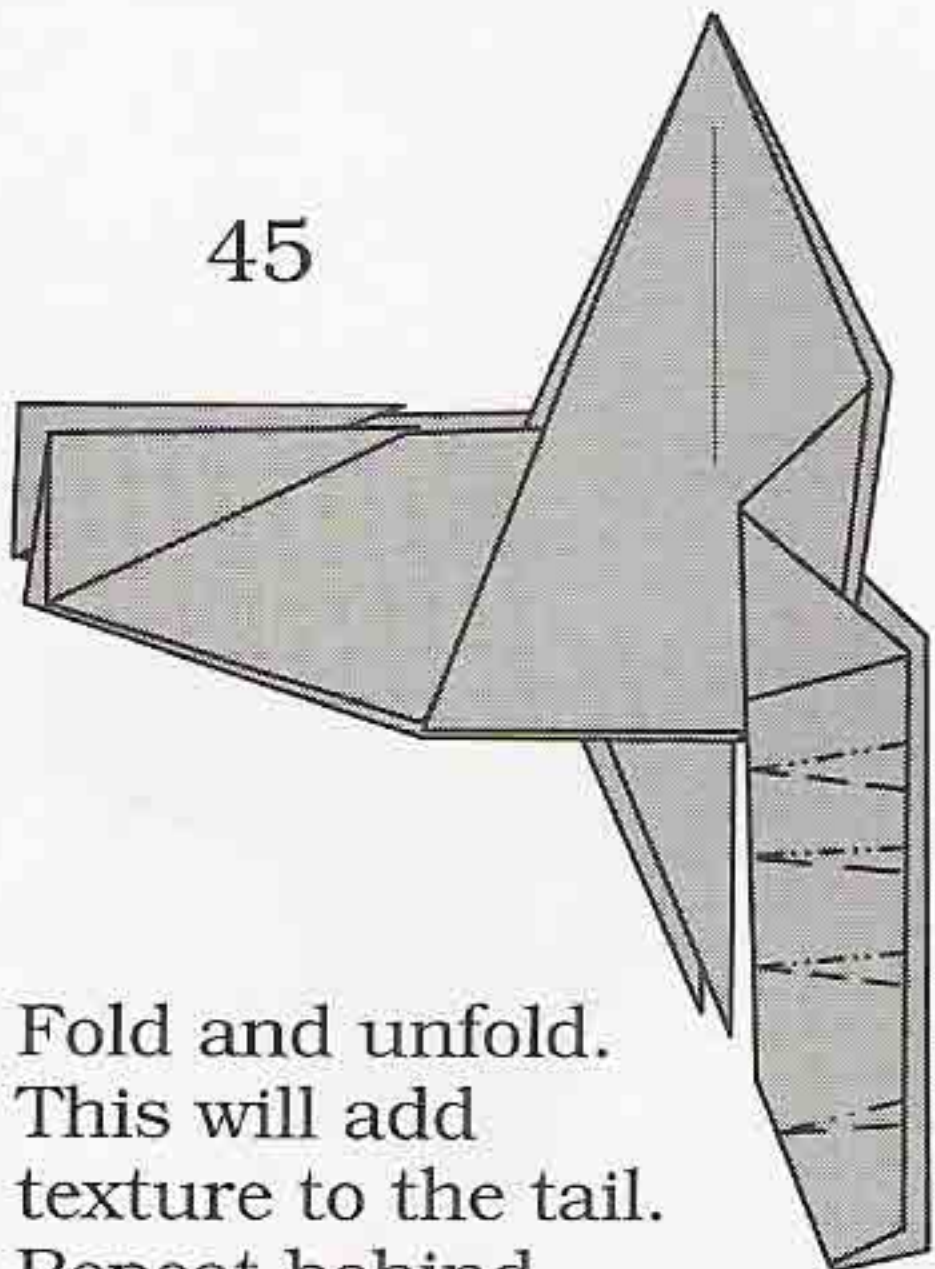

Fold and unfold. This will add texture to the tail. Repeat behind.

46

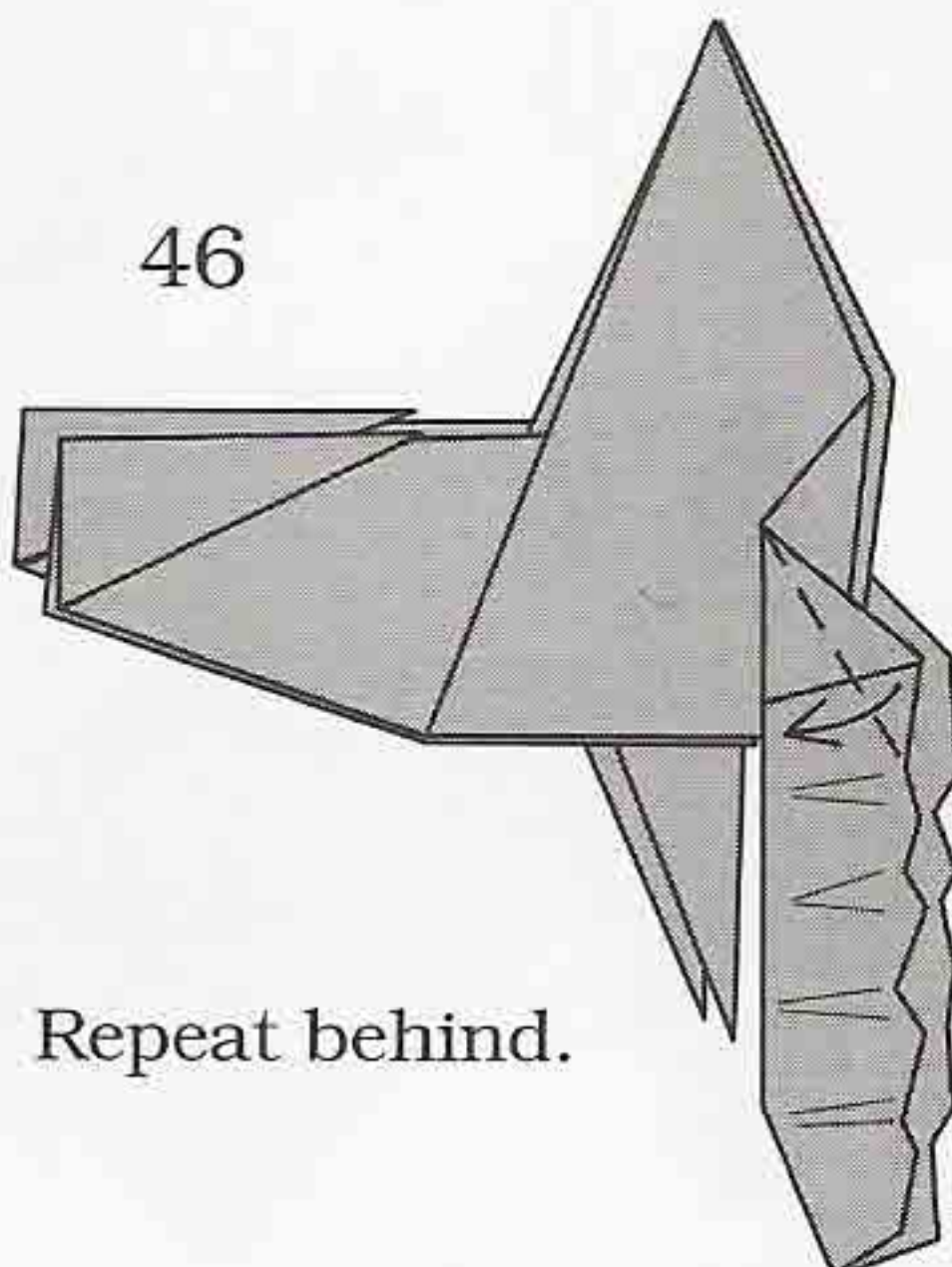

Repeat behind.

47

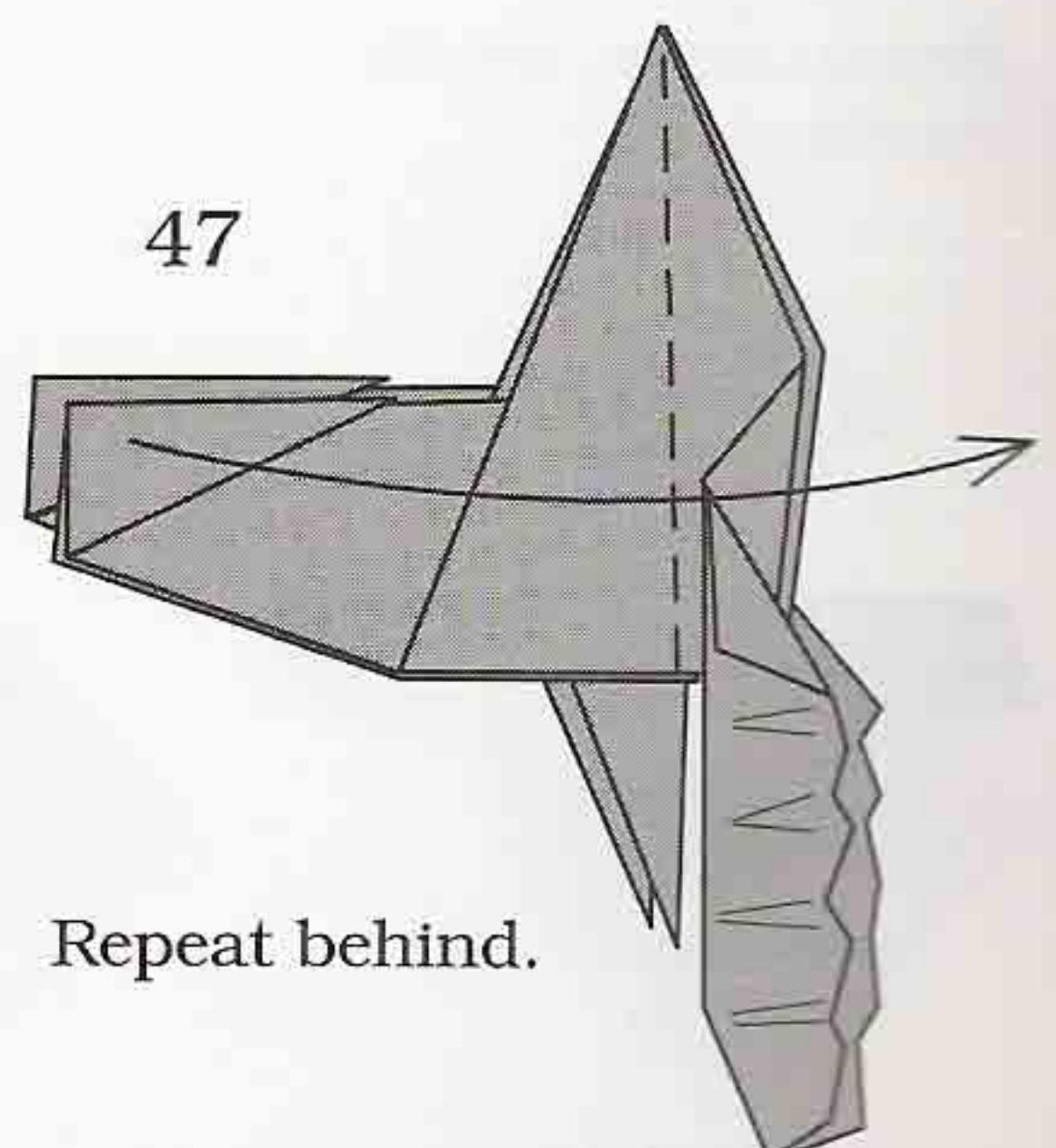

Repeat behind.

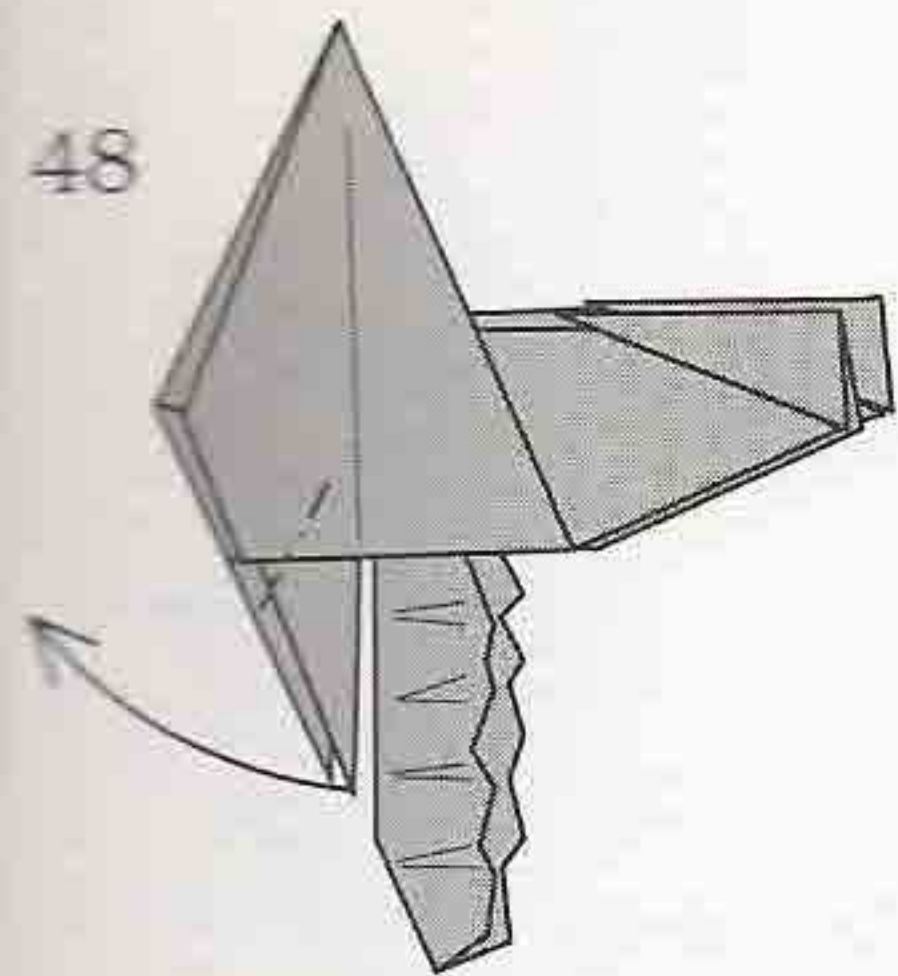

Reverse-fold.

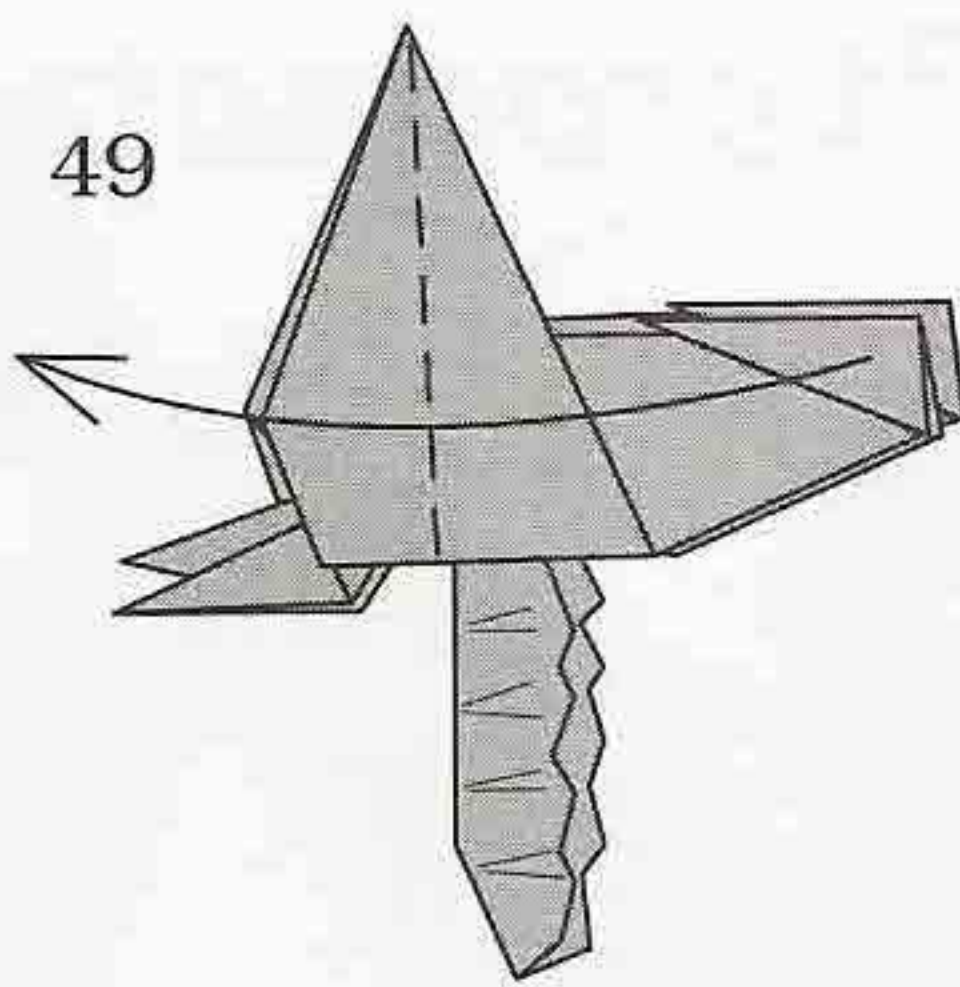

Repeat behind.

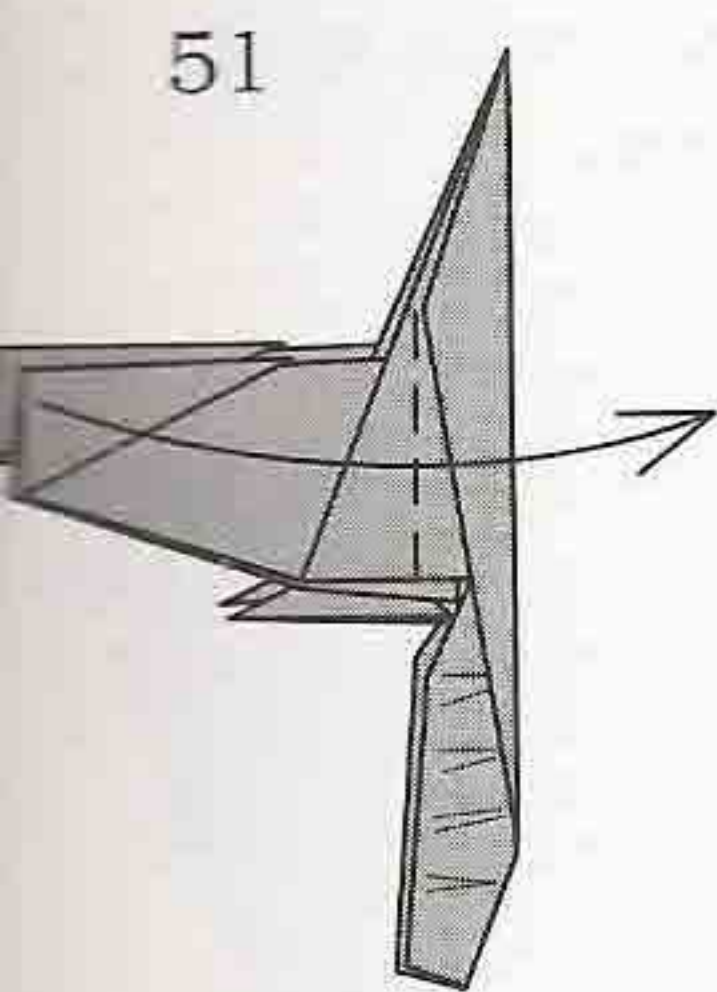
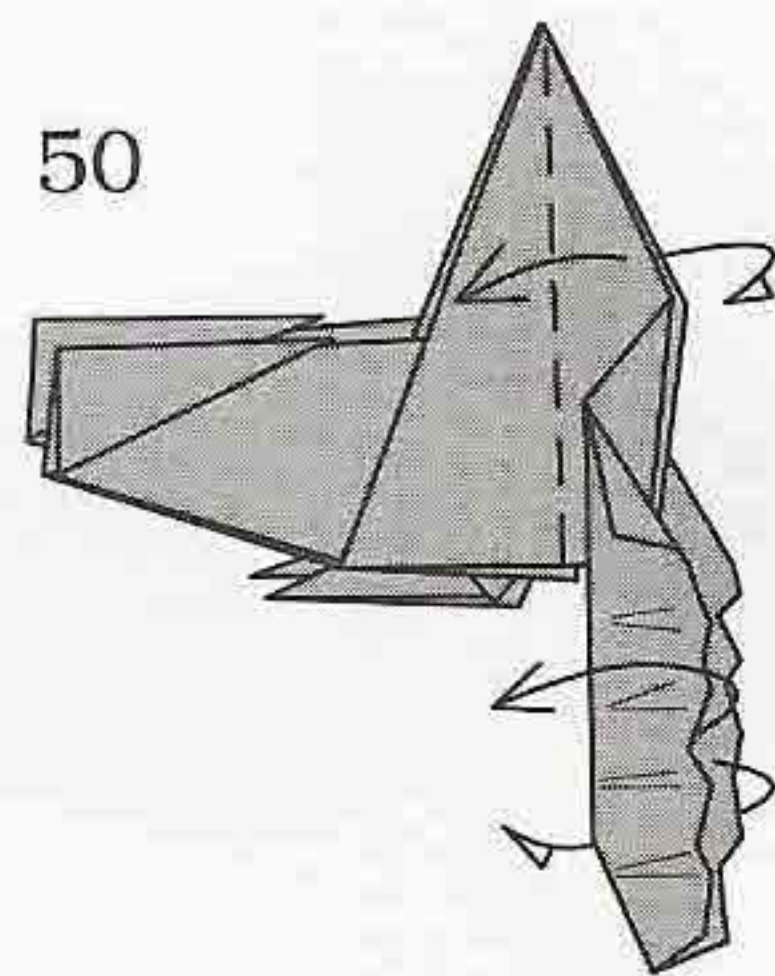

Repeat behind.

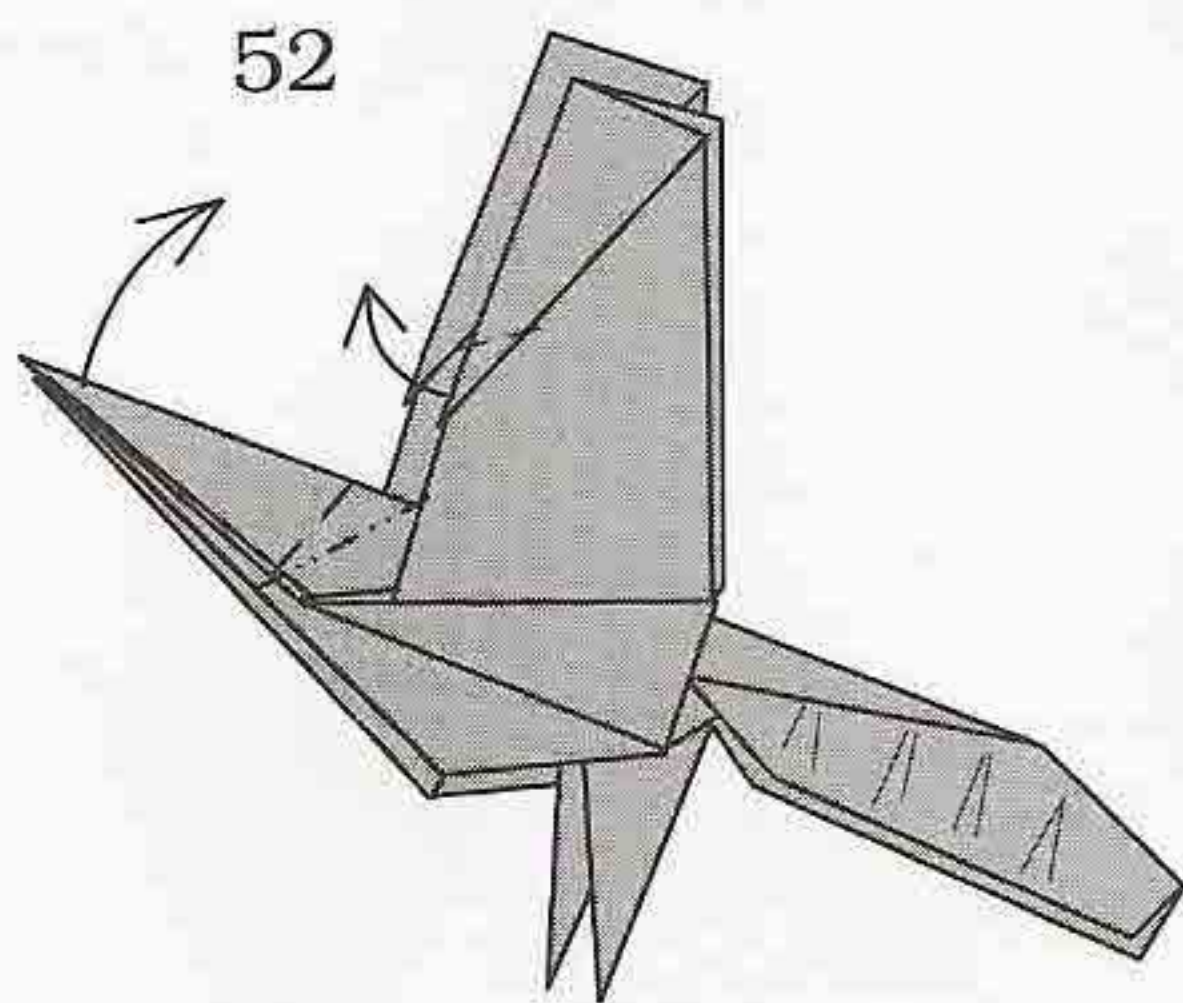

Crimp-fold the neck.
Outside-reverse-fold to form
the claws, repeat behind.

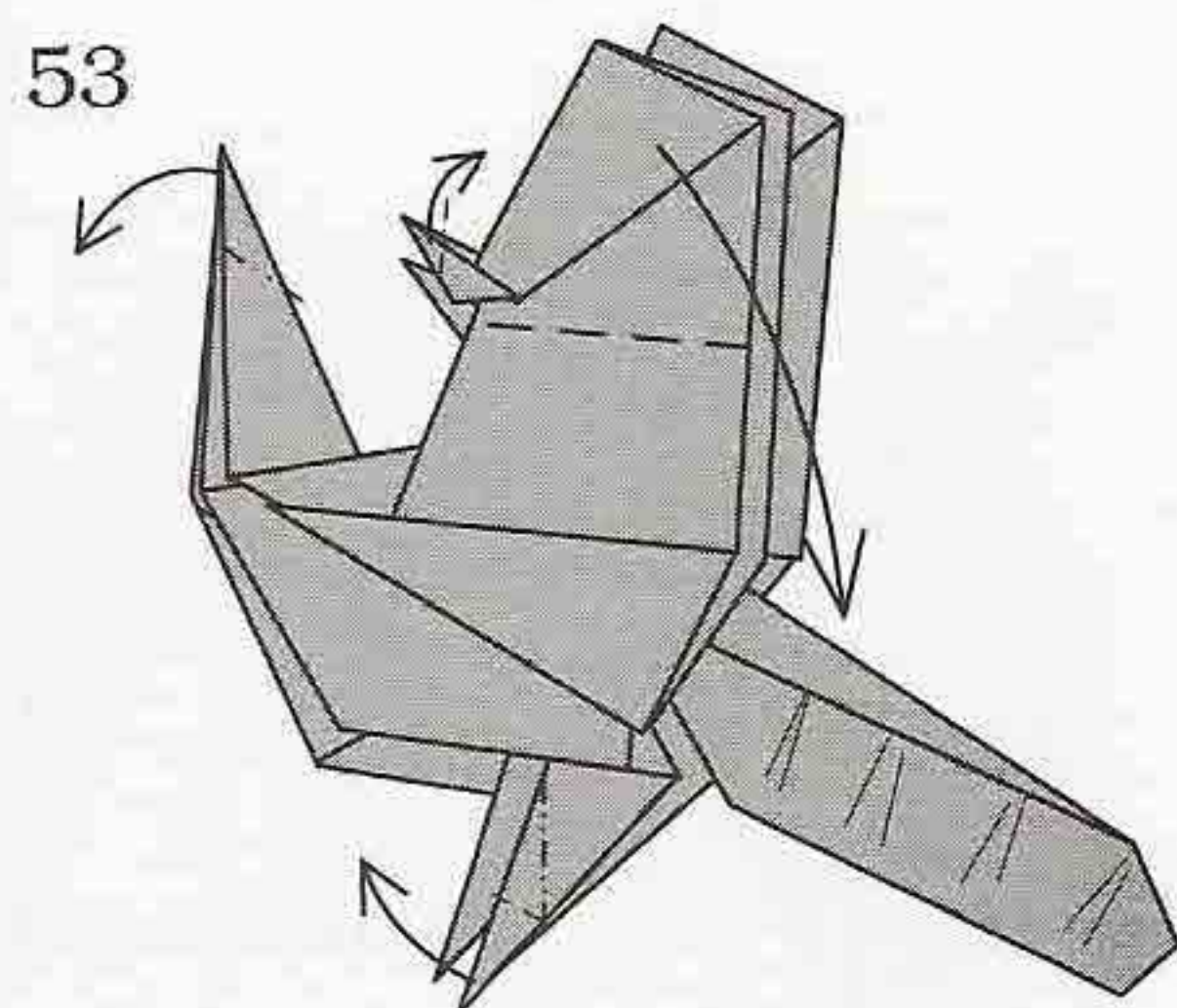

Repeat behind.

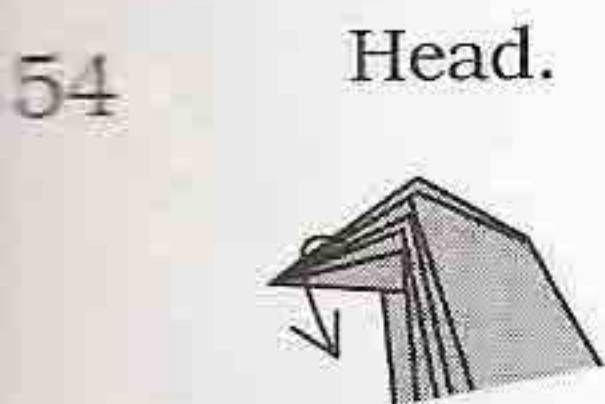

Fold two layers
down, repeat behind.

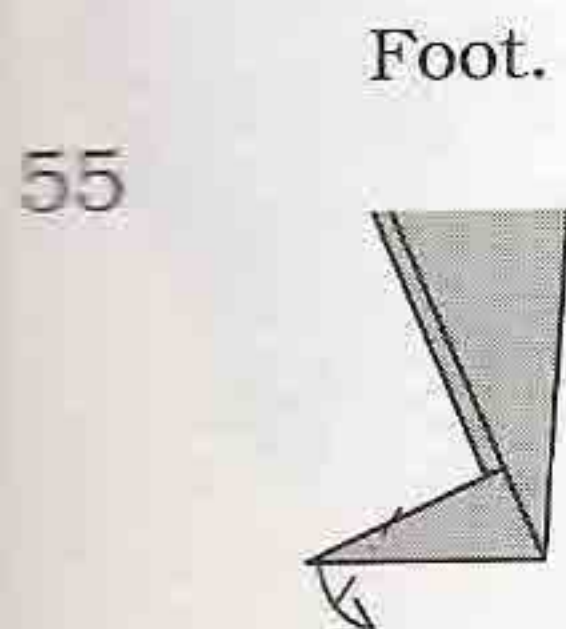

Reverse-fold,
repeat behind.

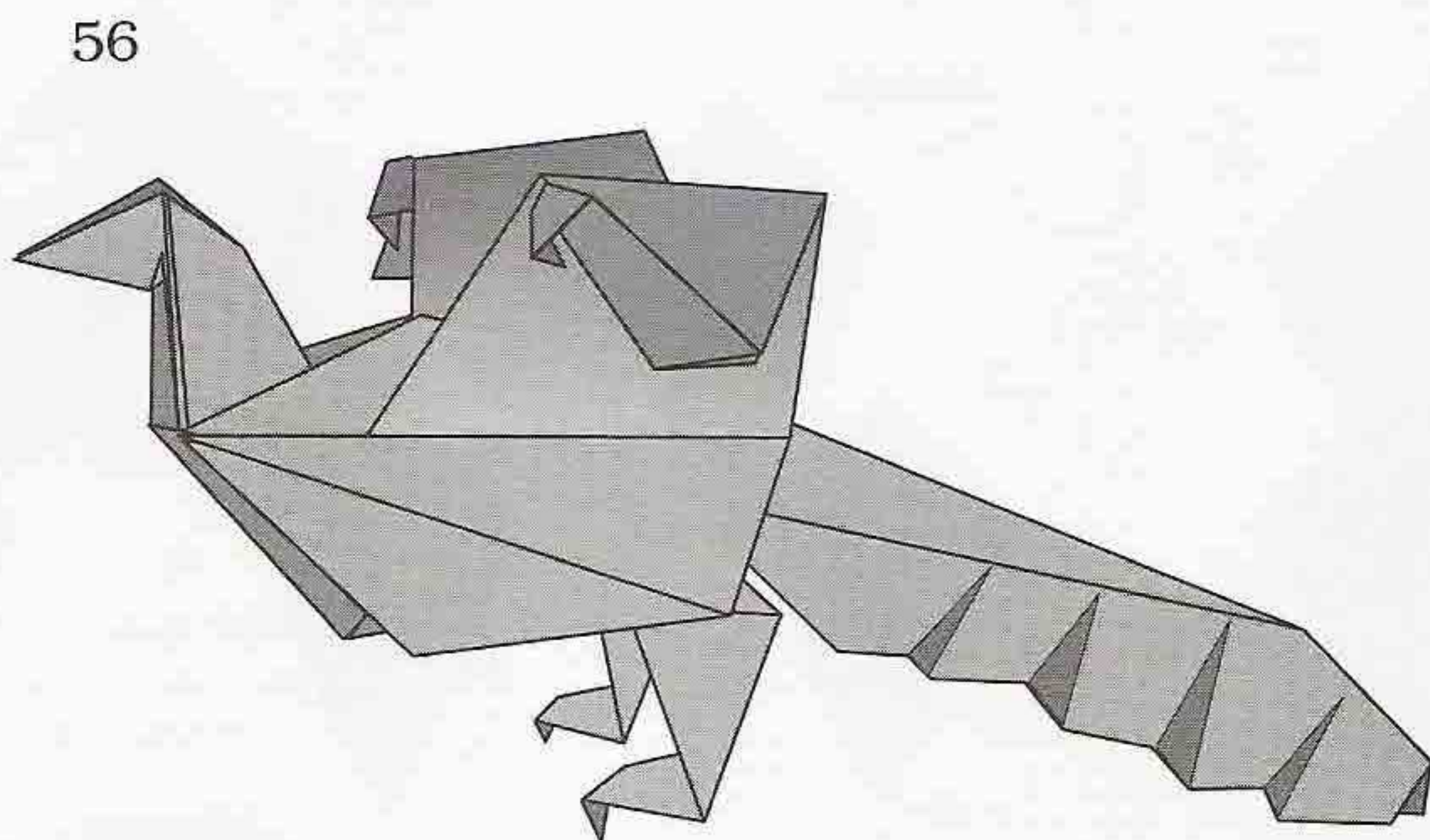

Archaeopteryx

Brachiosaurus

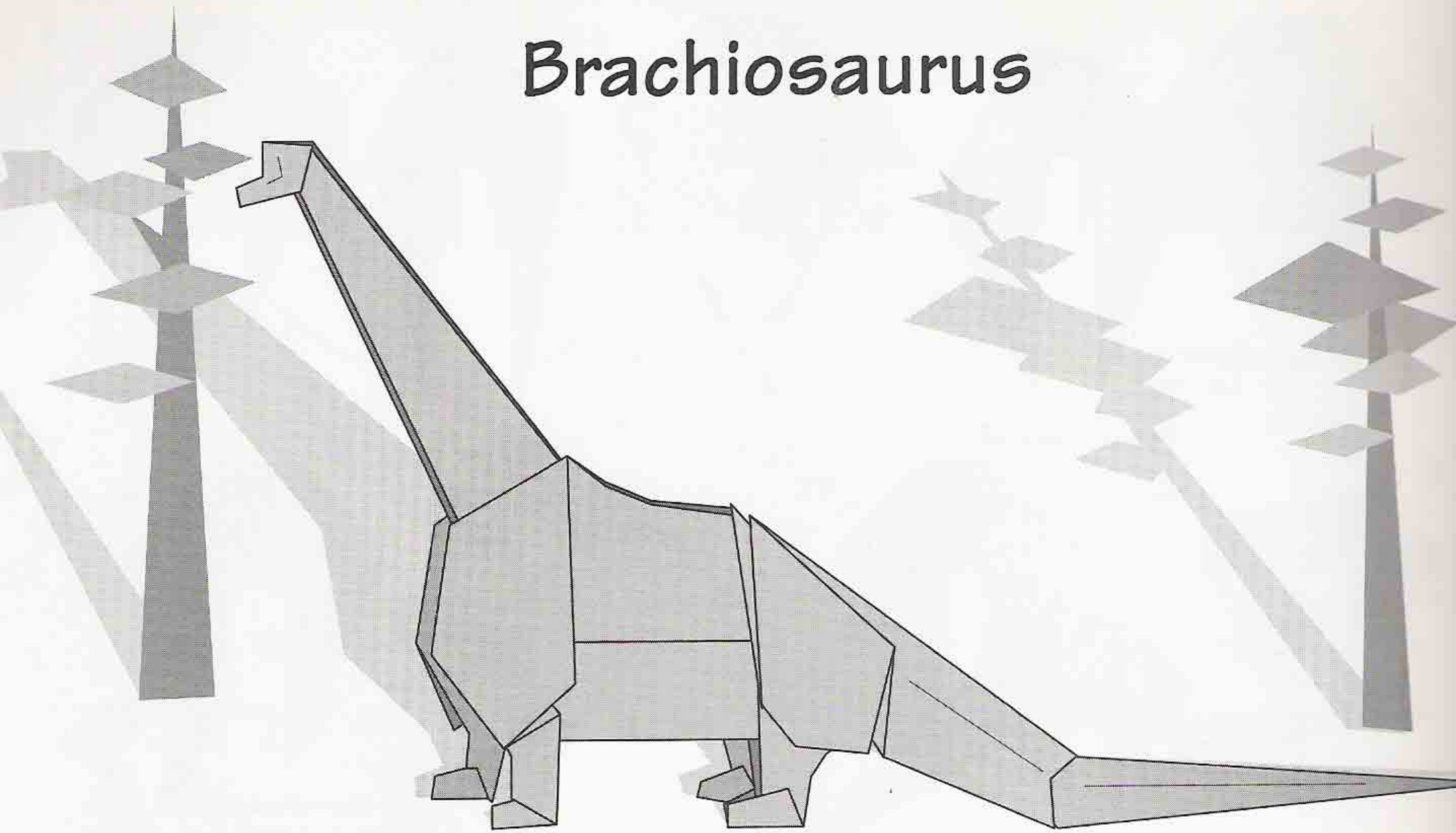

BRAKE-ee-oh-saw-rus

This 75 foot long, Jurassic dinosaur was called "arm lizard" because its front legs were longer than its back legs. The placement of the nose on top of its head was once thought to aid in breathing when submerged in deep water. Now some paleontologists believe it lived on high ground, eating pine needles, since the skeleton could not have withstood the pressure of deep water. Fossils were found in Colorado.

Begin with step 31 of the Apatosaurus (page 64).

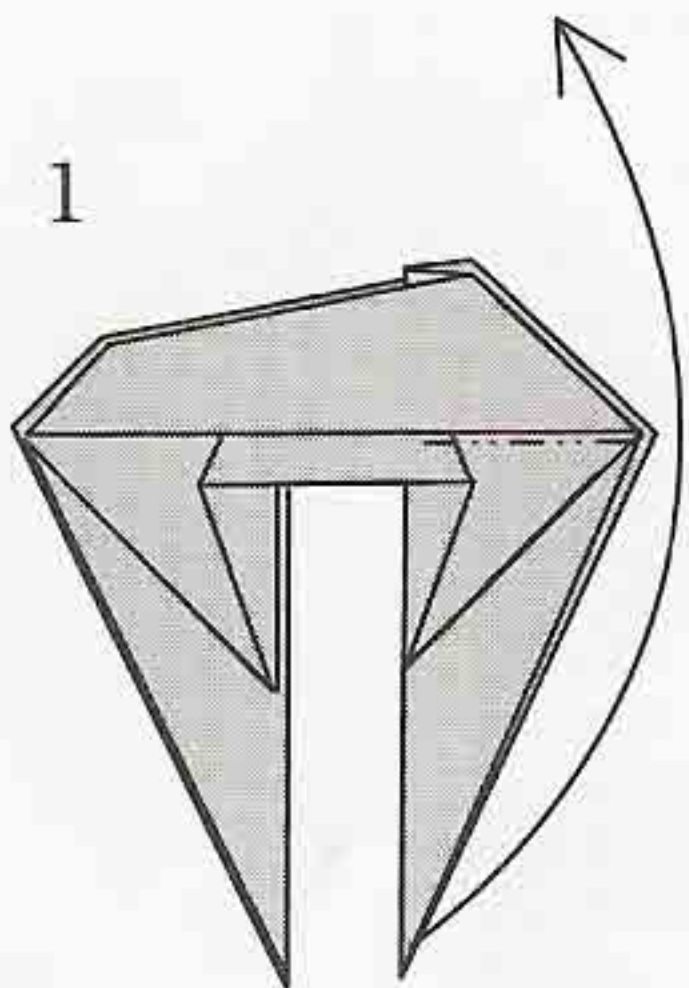

Reverse-fold.

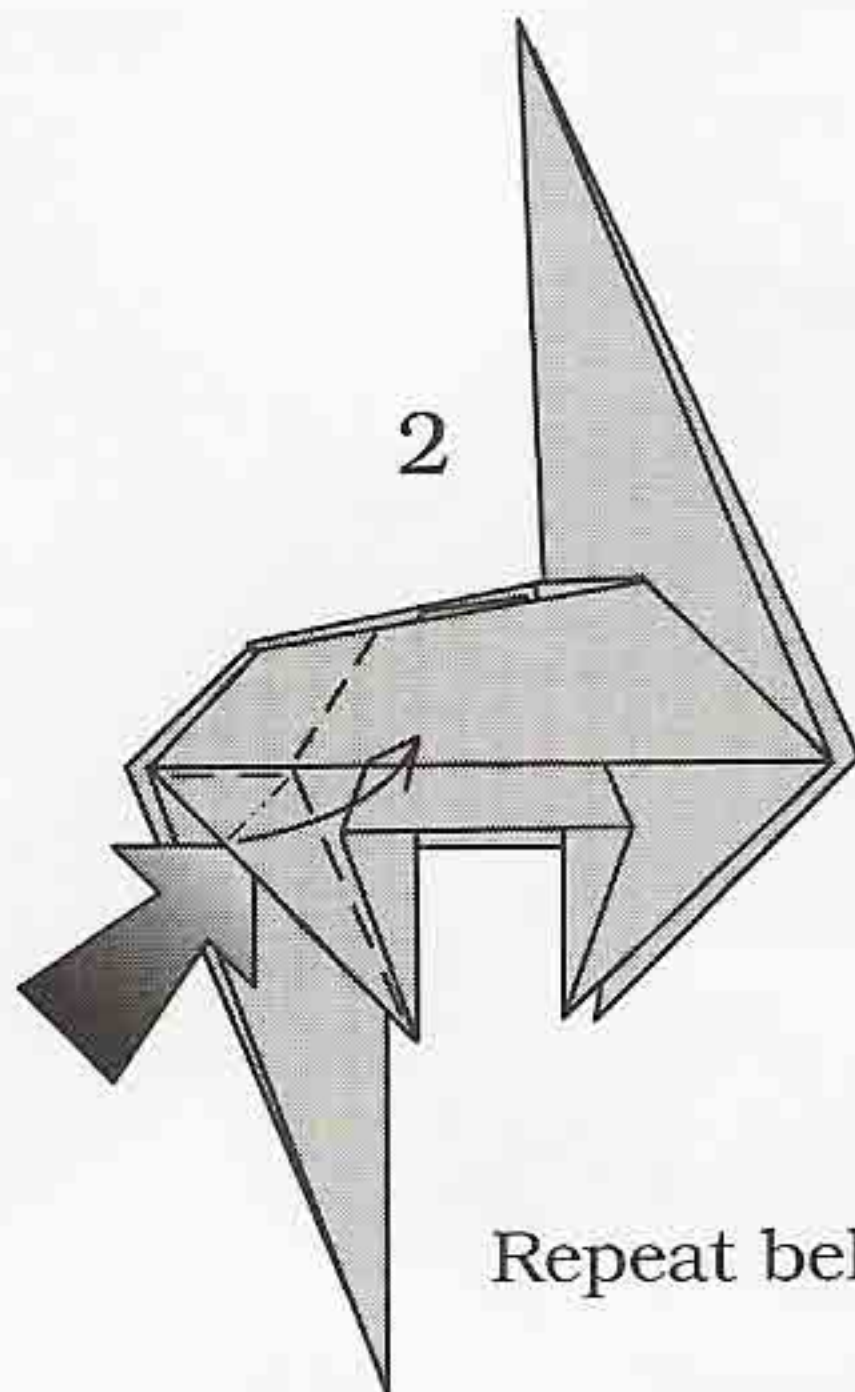

Repeat behind.

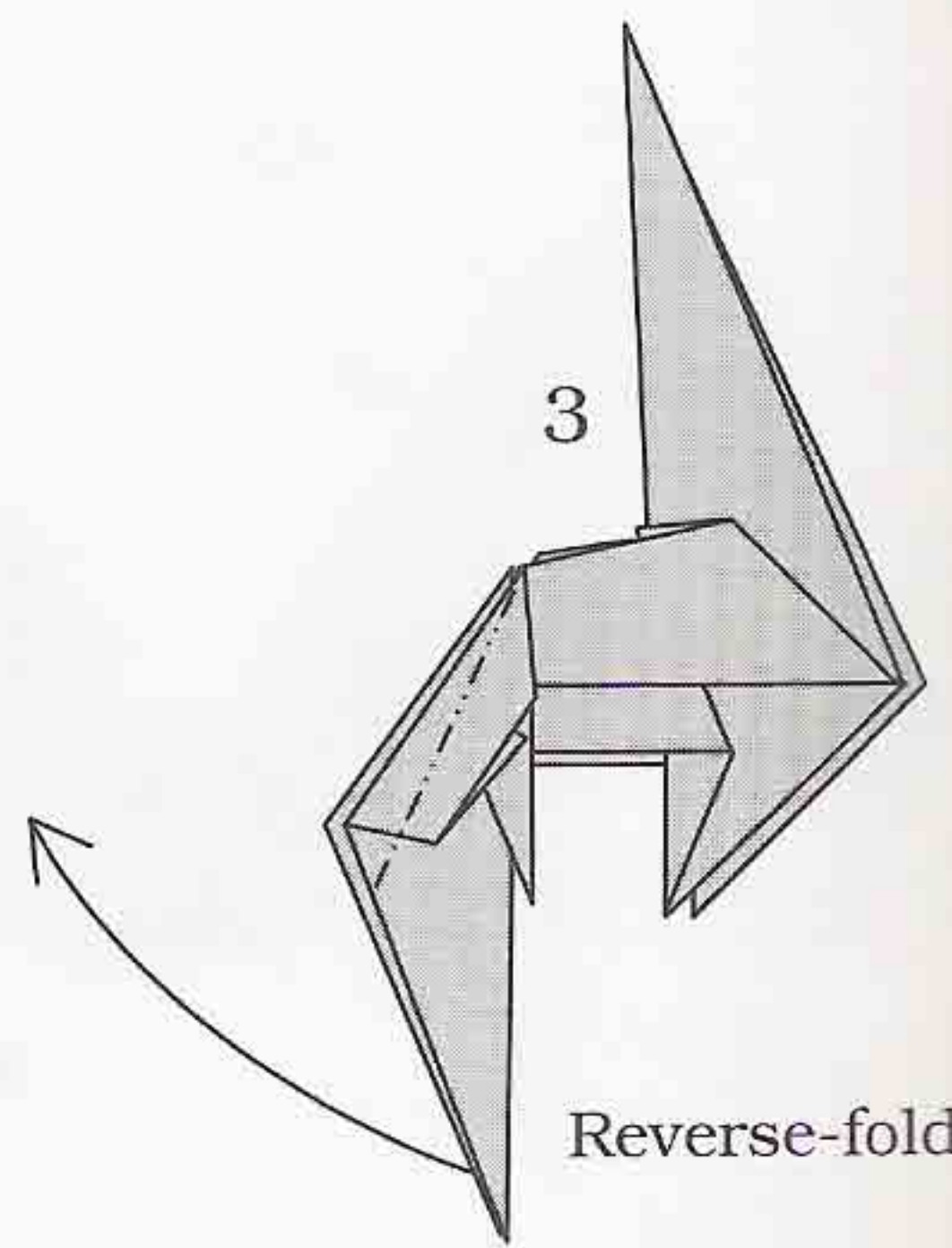

Reverse-fold.

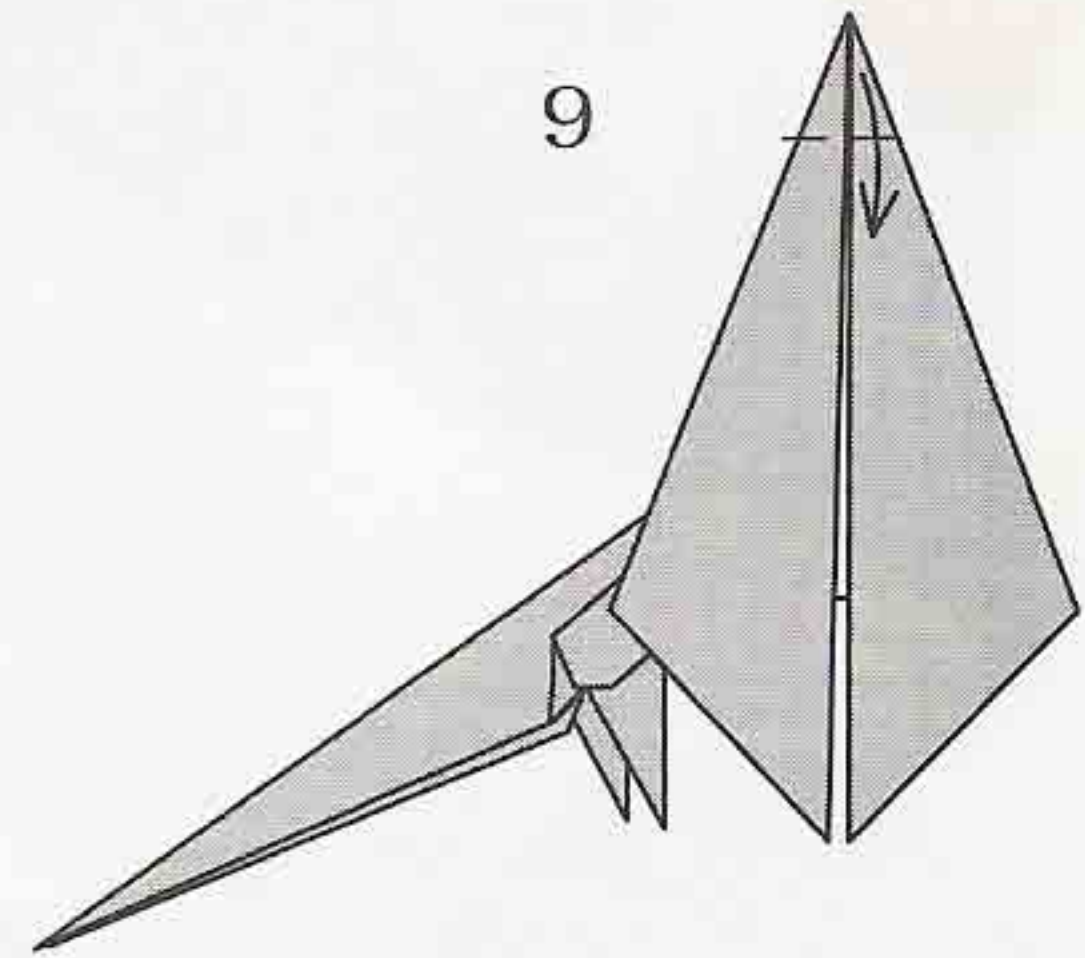
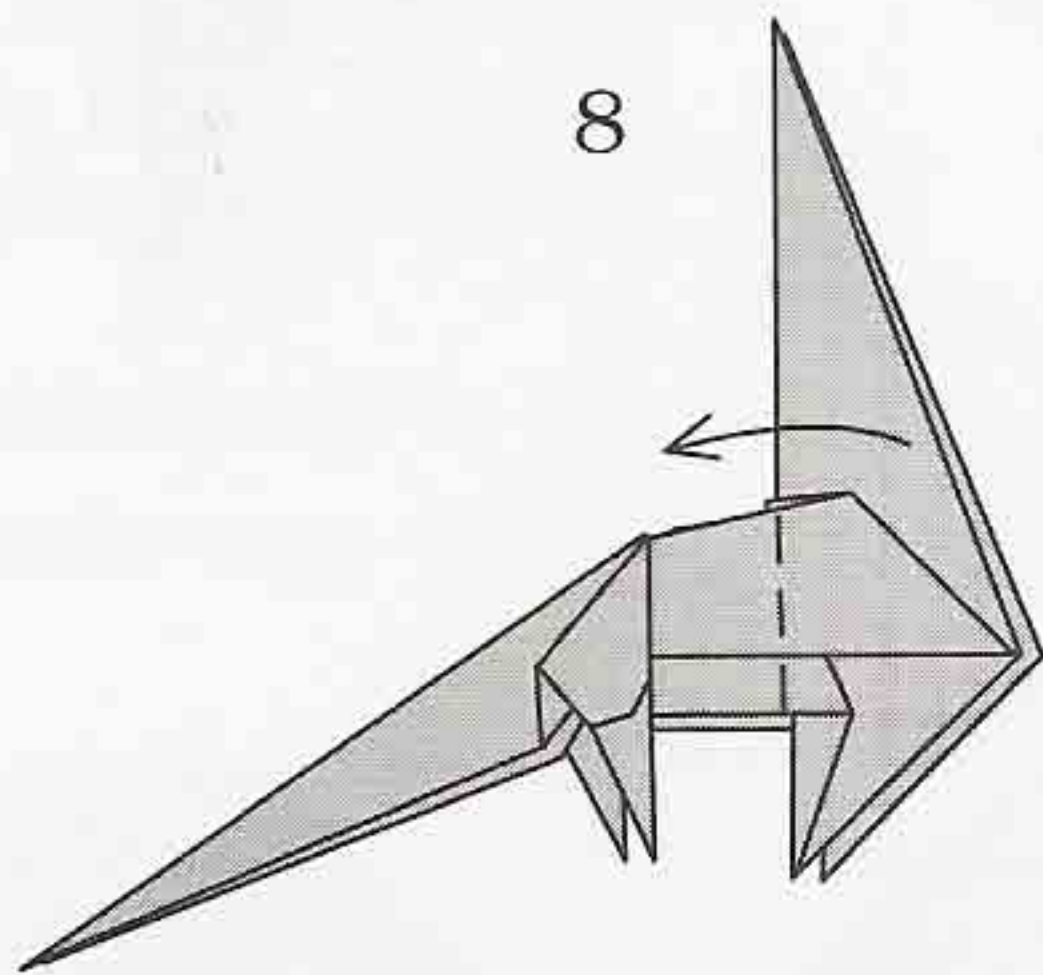
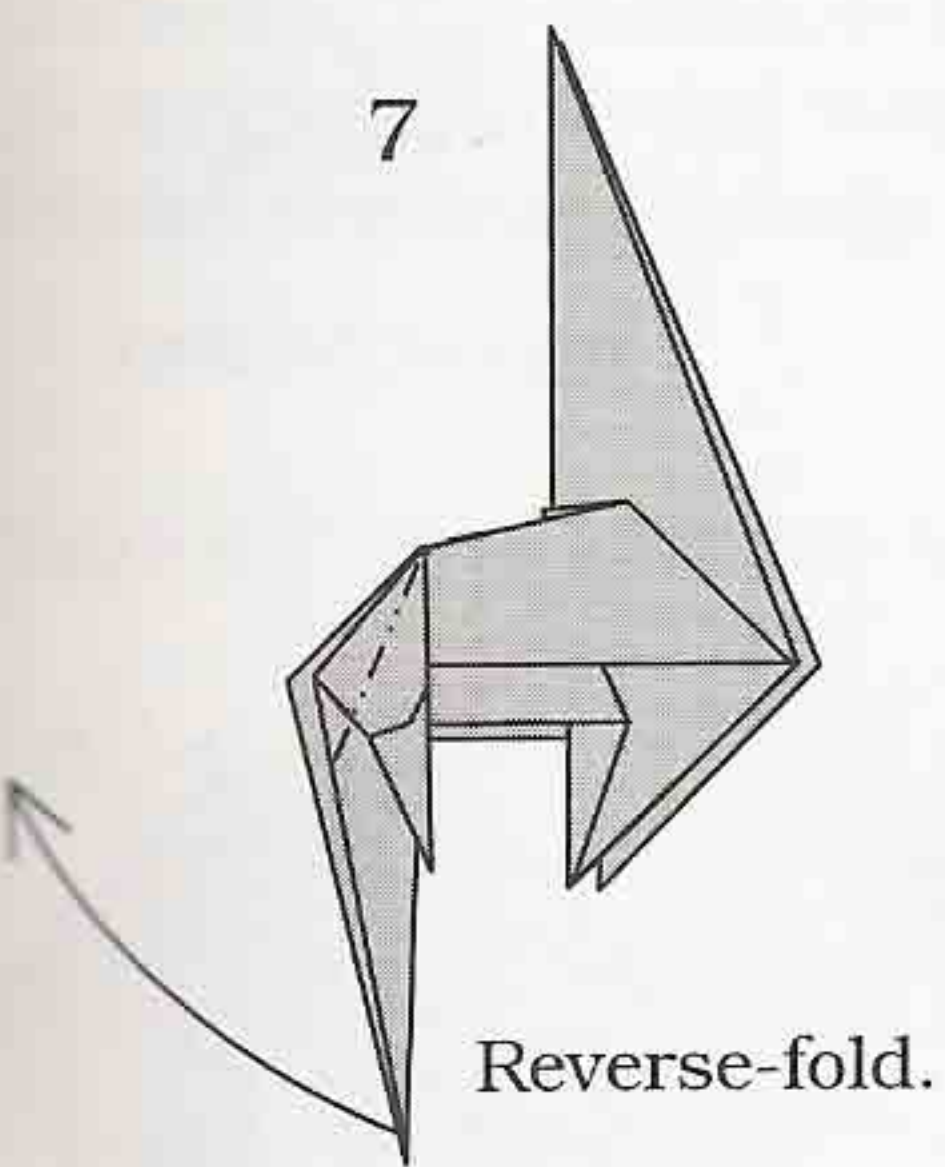
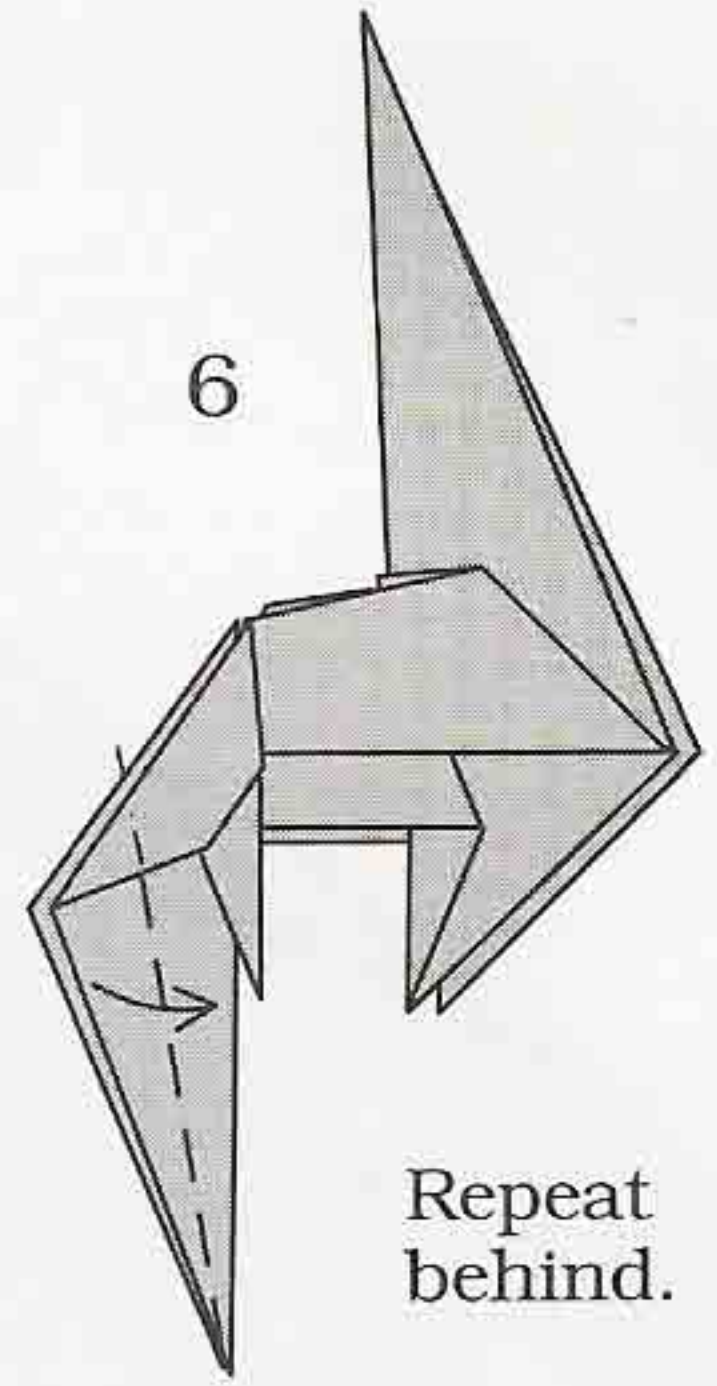
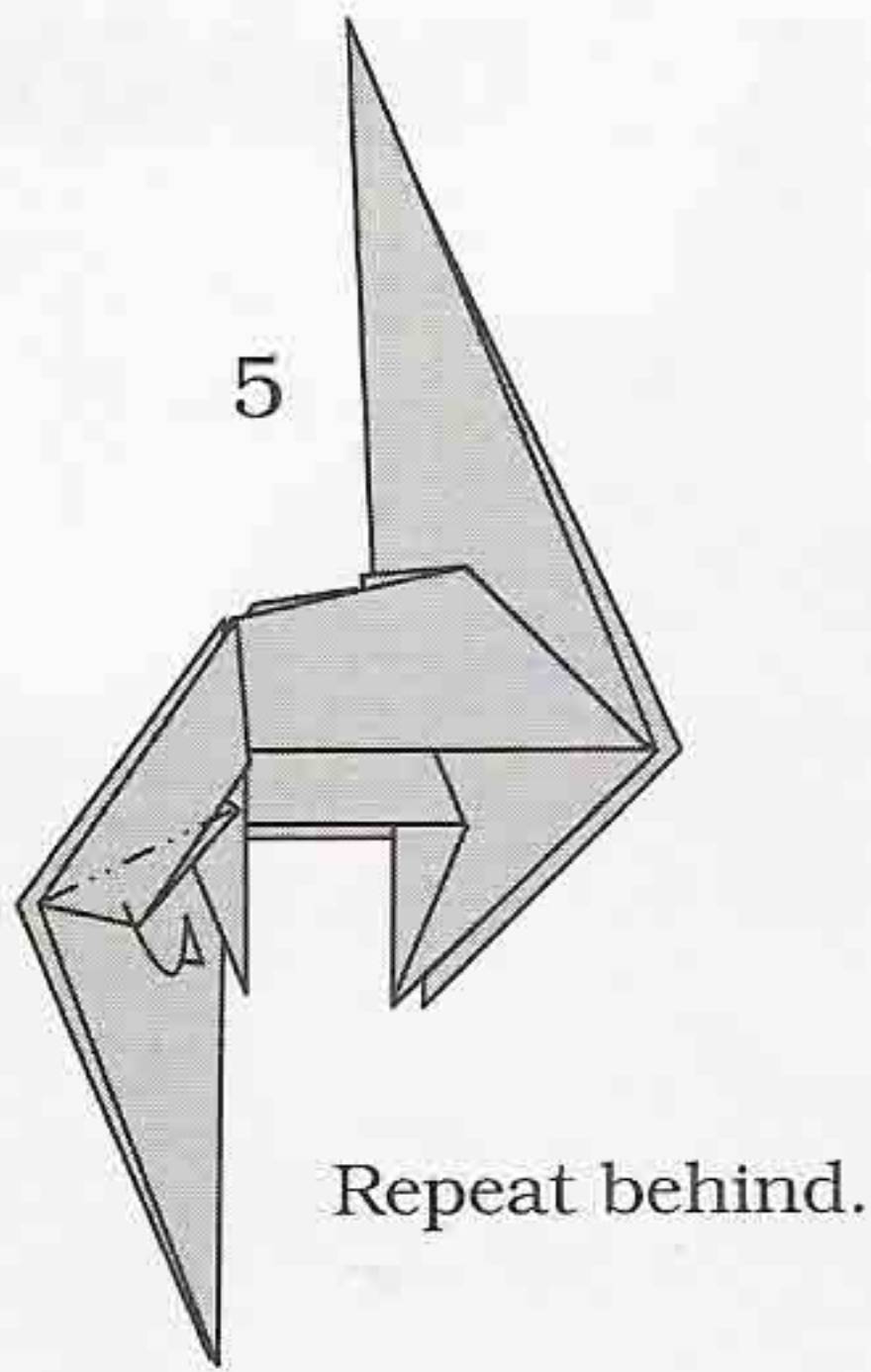
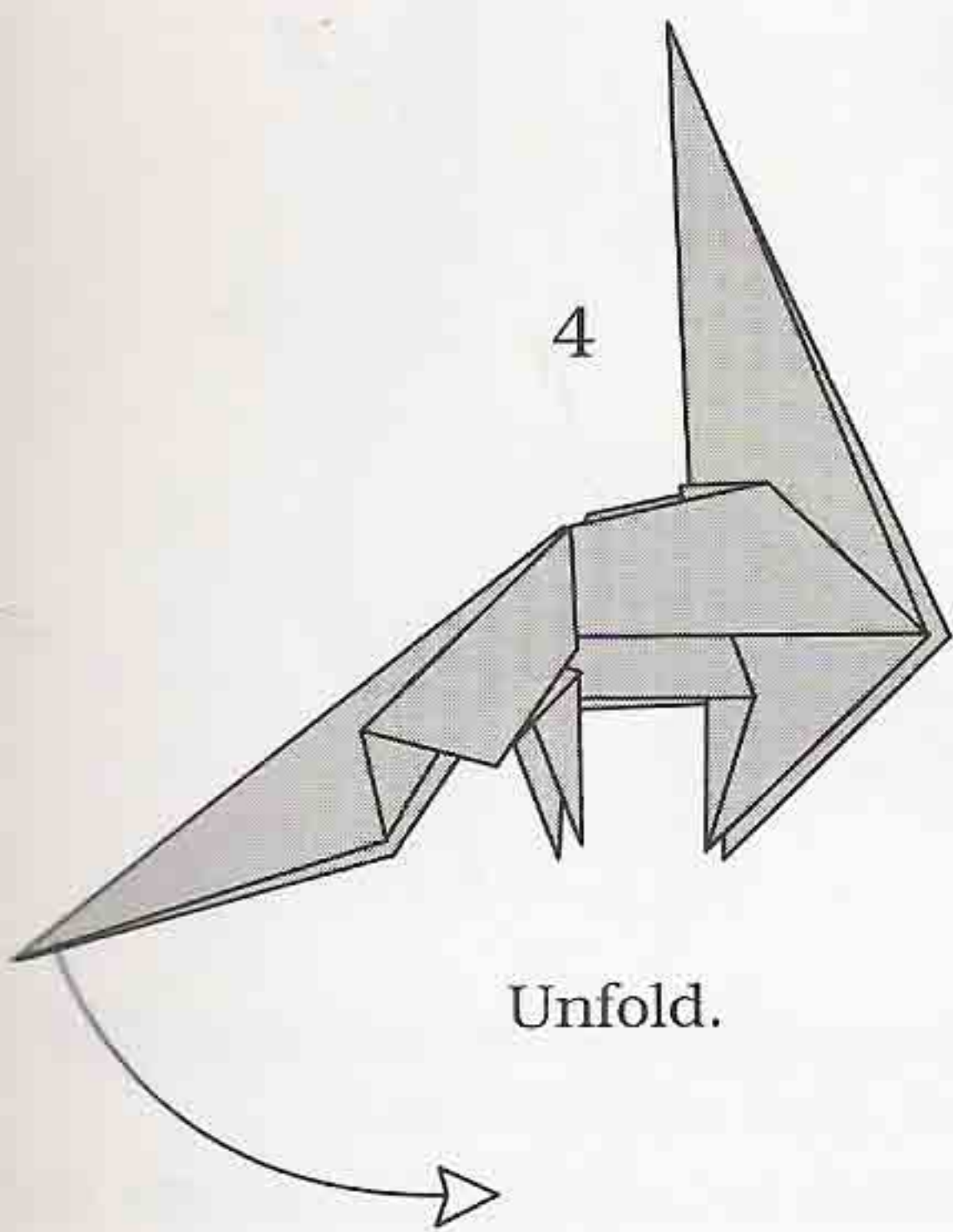

Head.

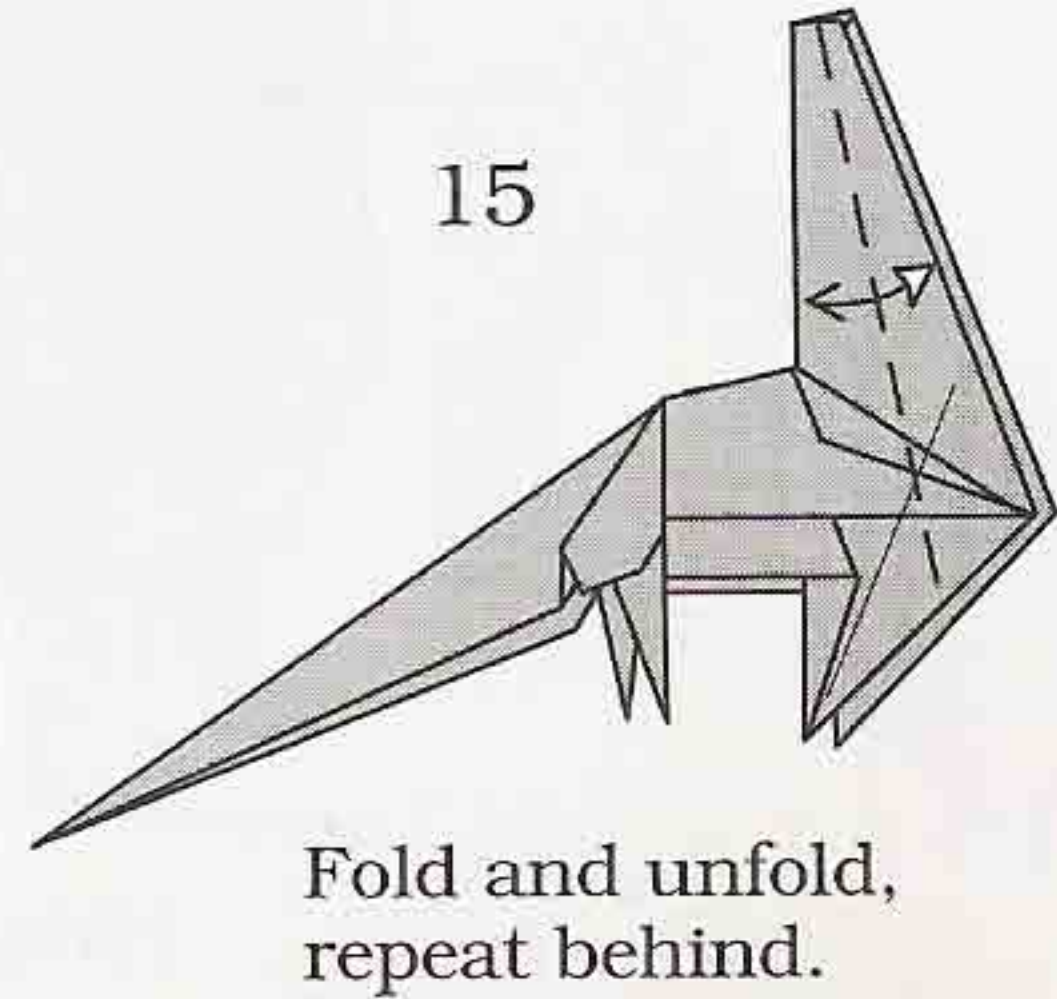
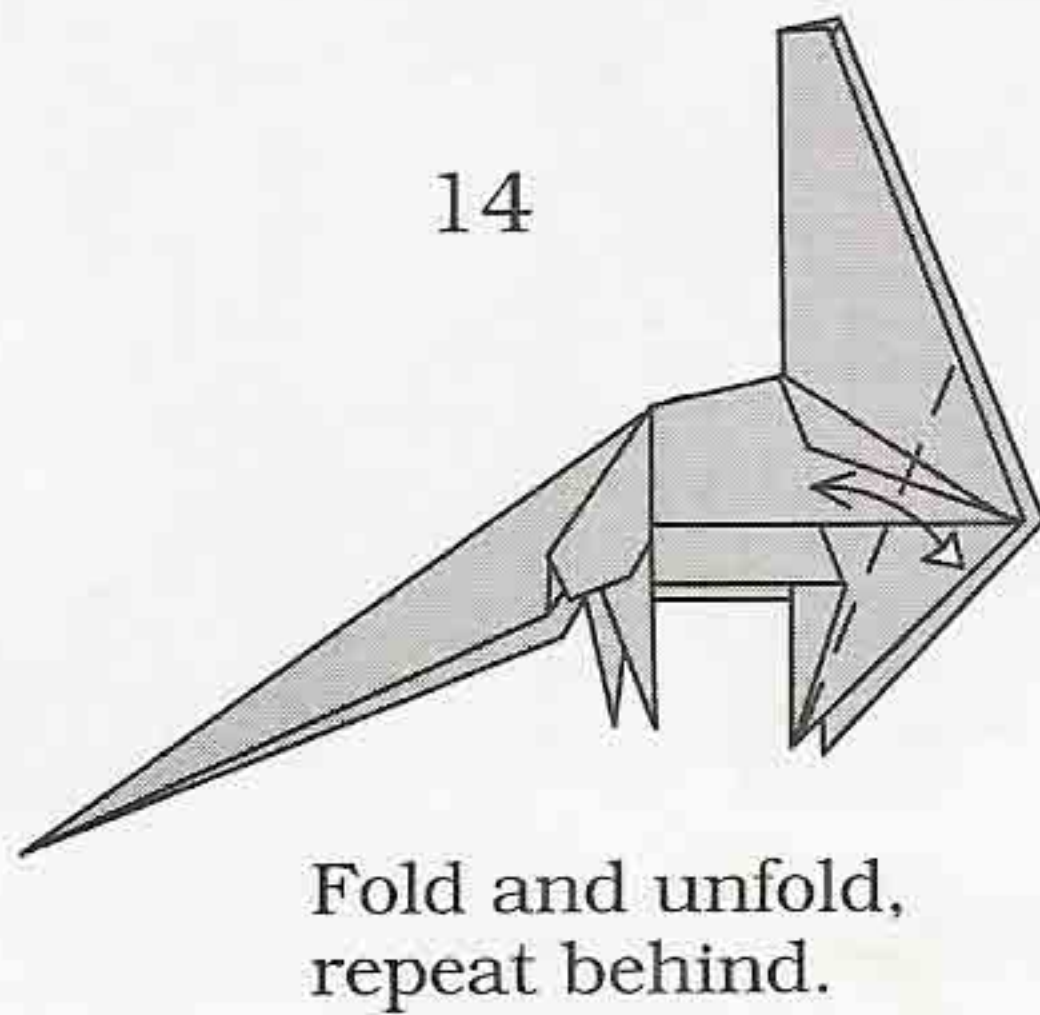
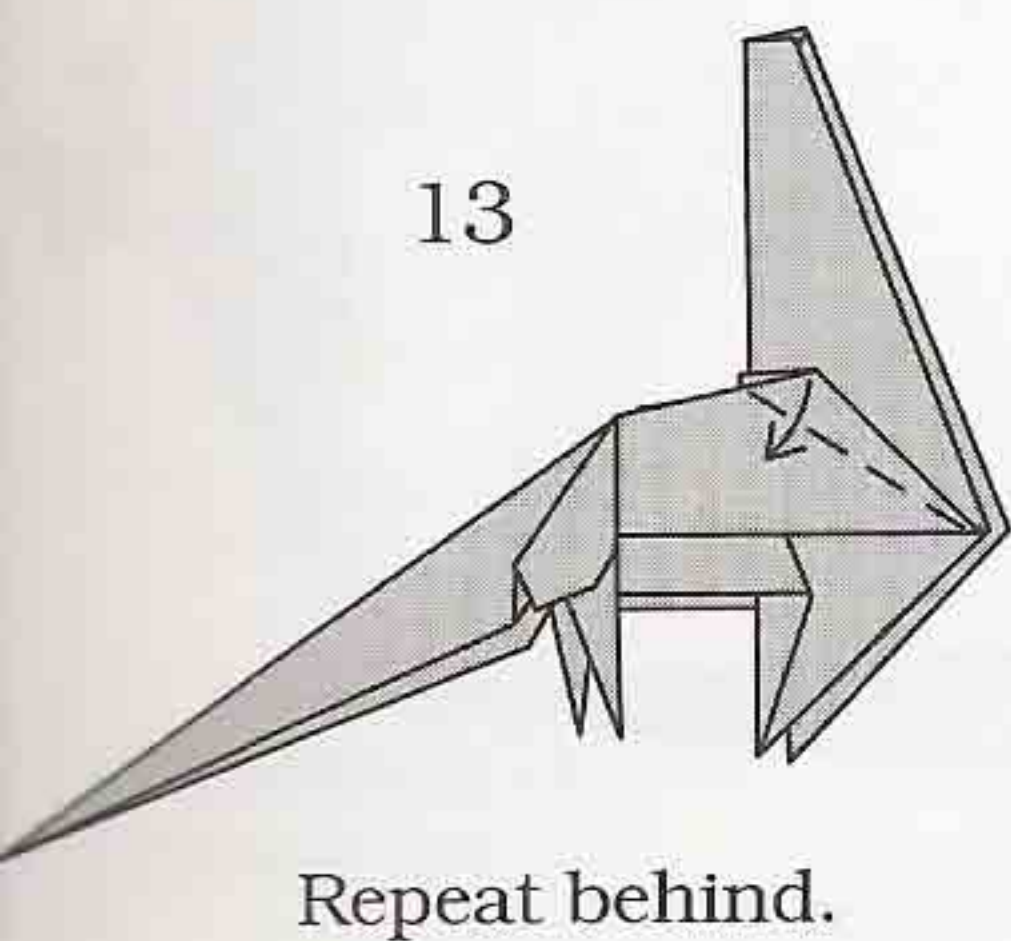
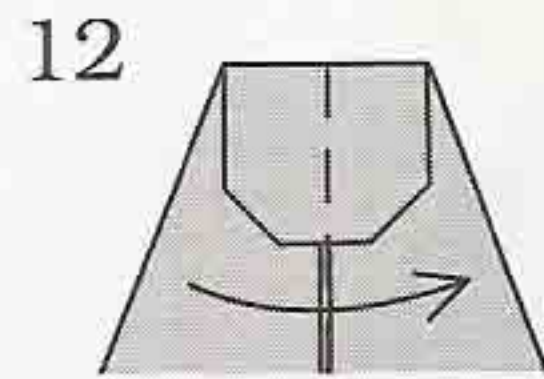
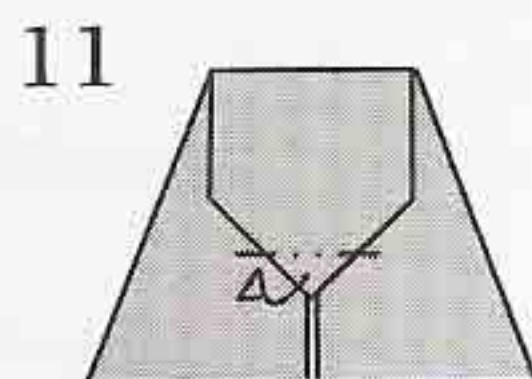
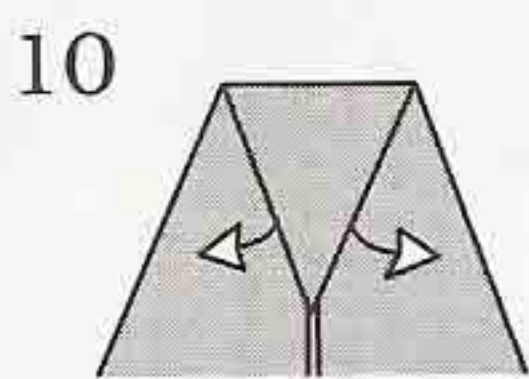

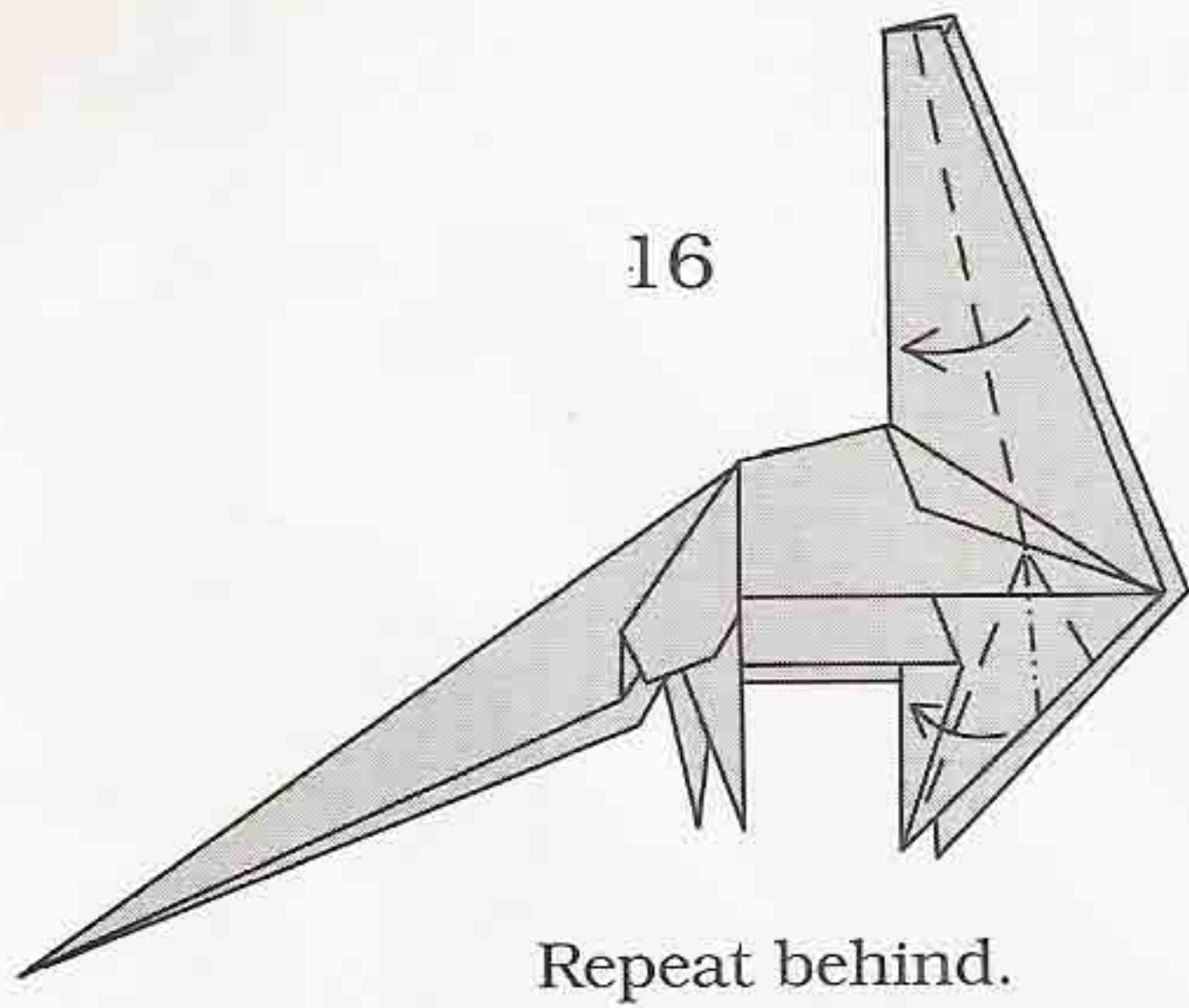

16

Repeat behind.

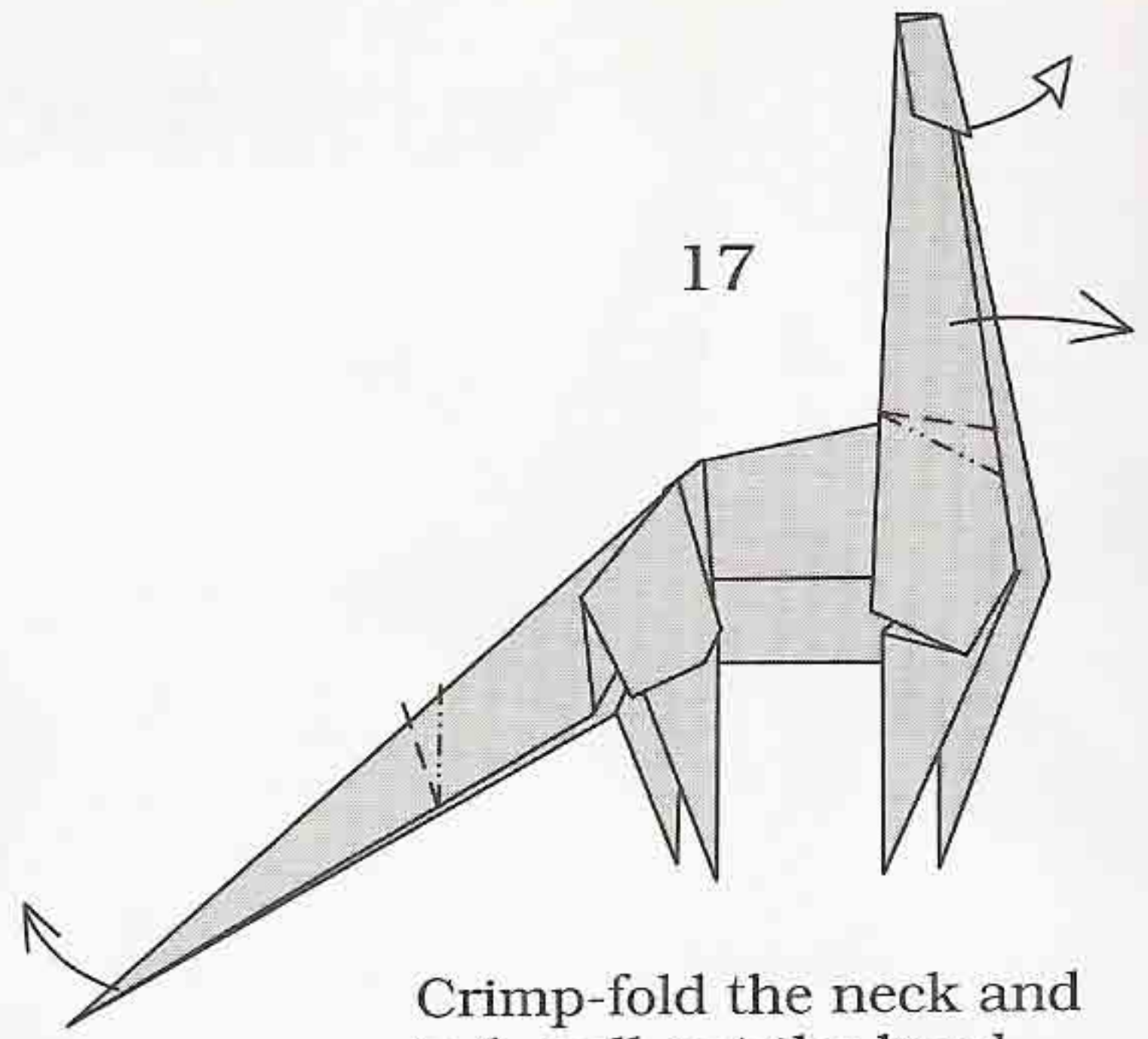

17

Crimp-fold the neck and tail, pull out the head.

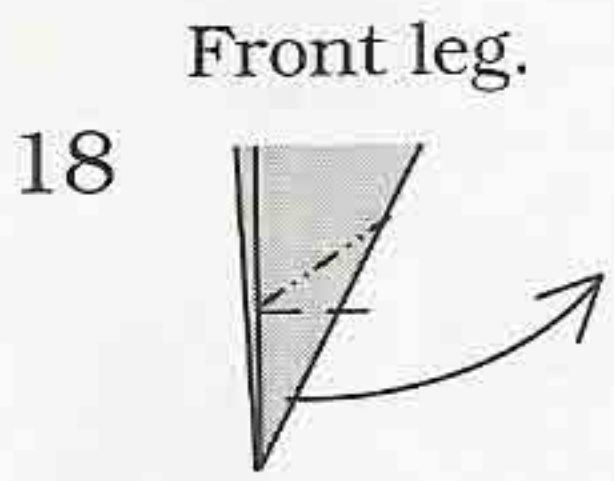

18

Front leg.

Repeat behind.

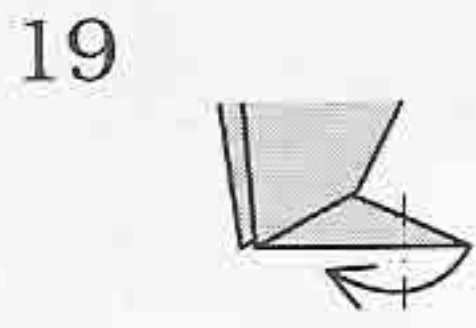

19

Repeat behind.

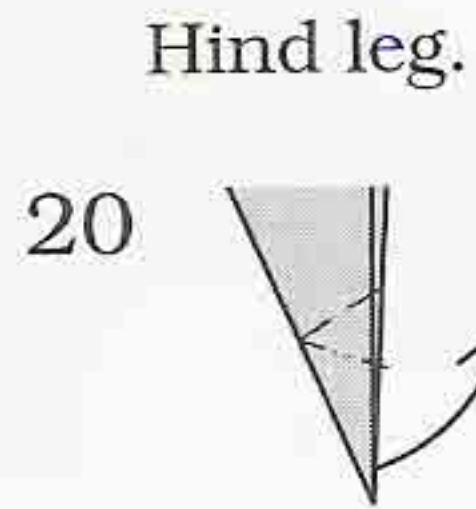

20

Hind leg.

Repeat behind.

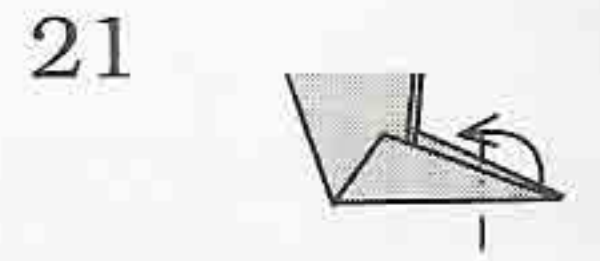

21

Repeat behind.

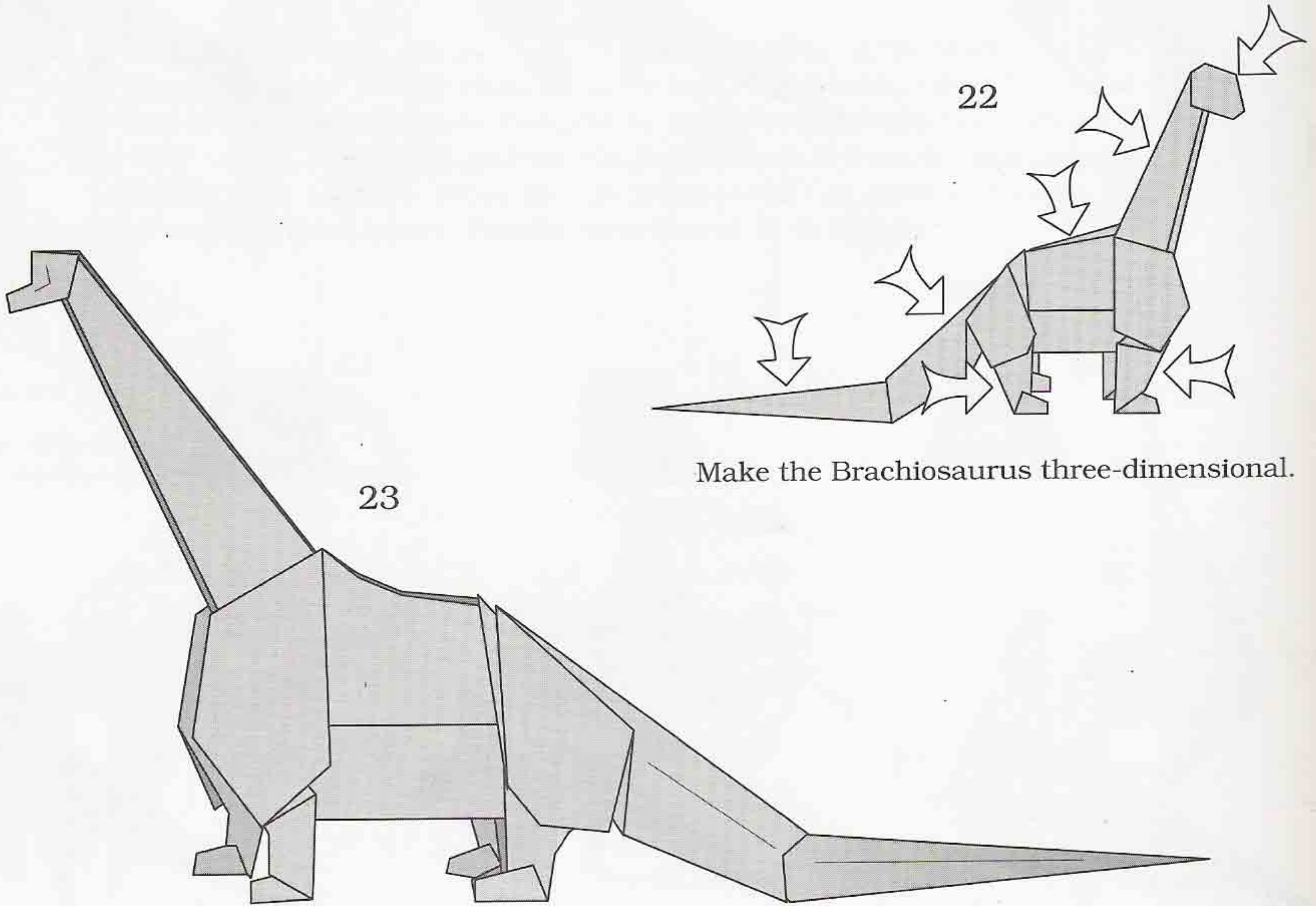

22

Make the Brachiosaurus three-dimensional.

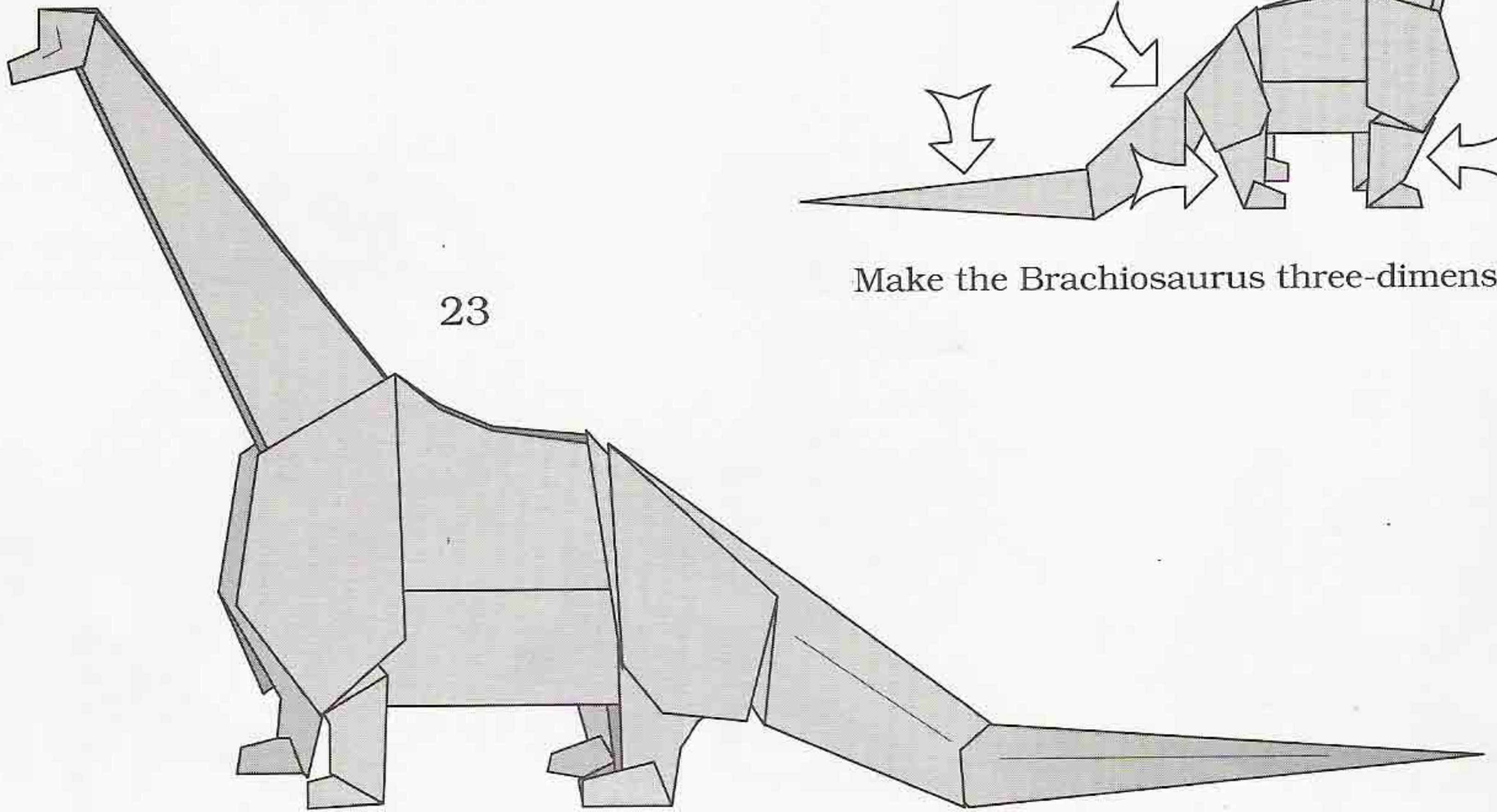

23

Brachiosaurus

Dimetrodon

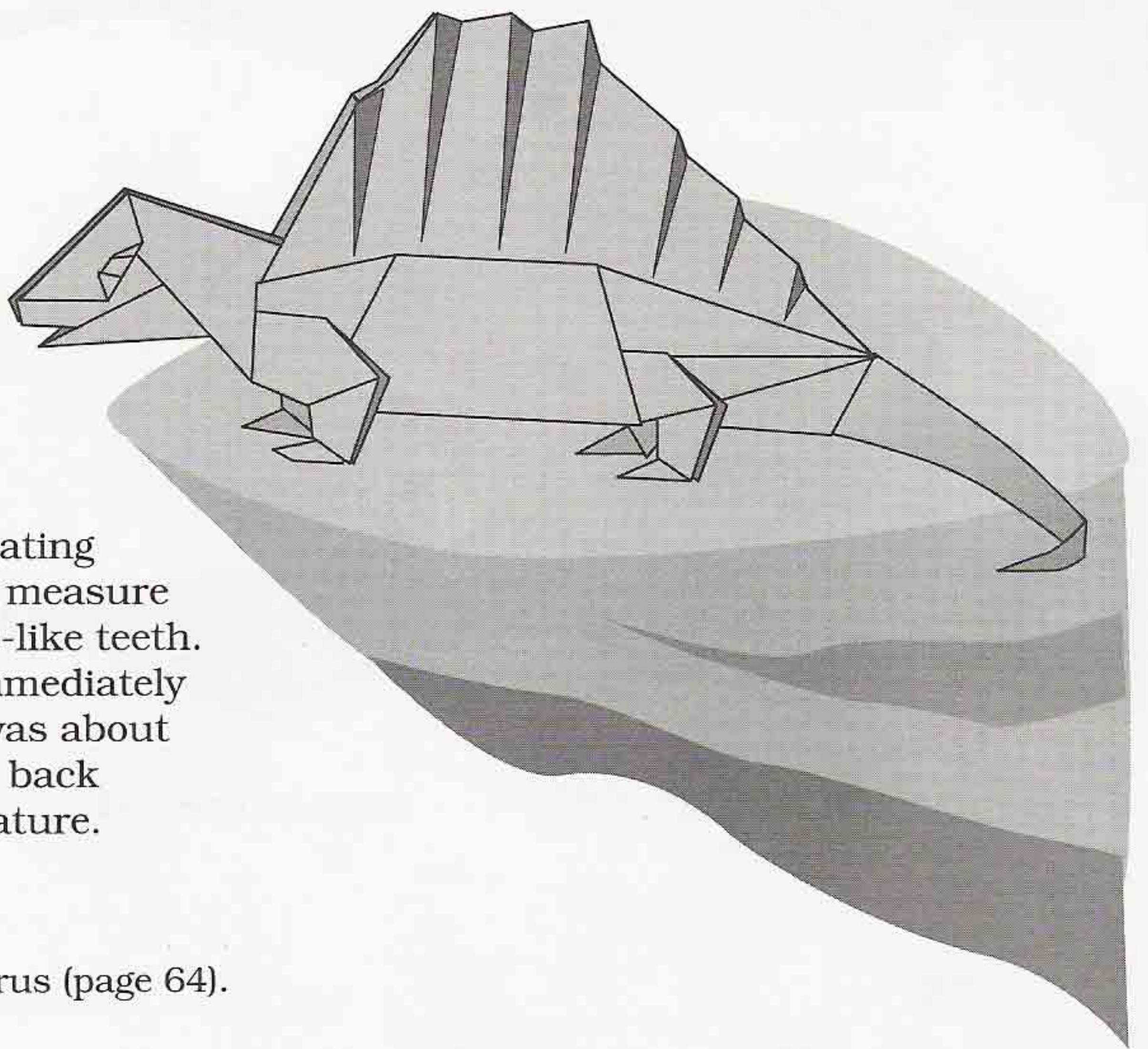

di-ME-tro-don

This was a very powerful meat eating reptile. Its name means "double measure tooth" because of its many knife-like teeth. It lived in the Permian Period immediately preceding the Mesozoic Era. It was about 10 feet long and the "sail" on its back helped regulate its body temperature.

Begin with step 26 of the Apatosaurus (page 64).

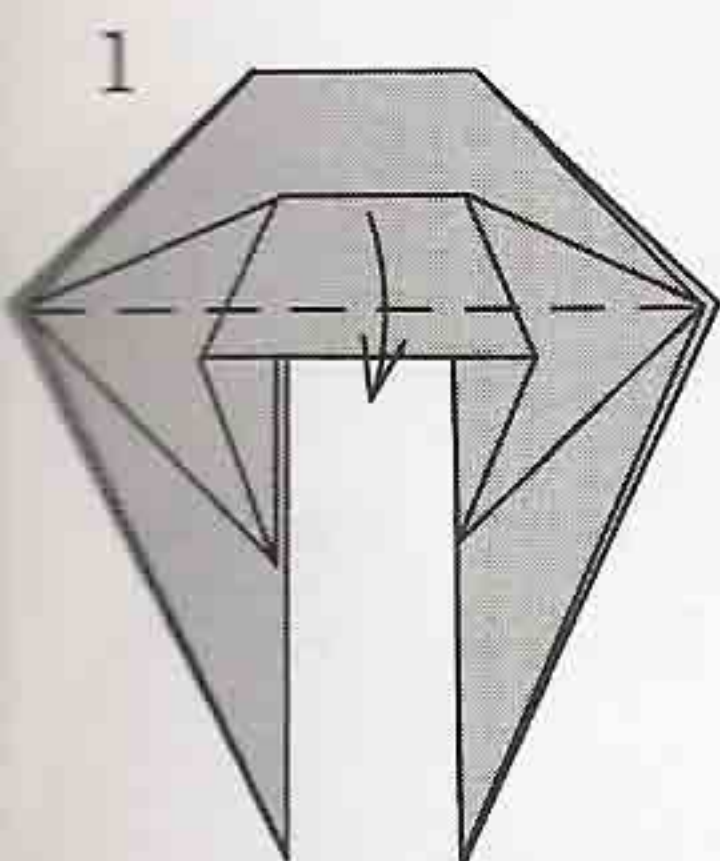

Repeat behind.

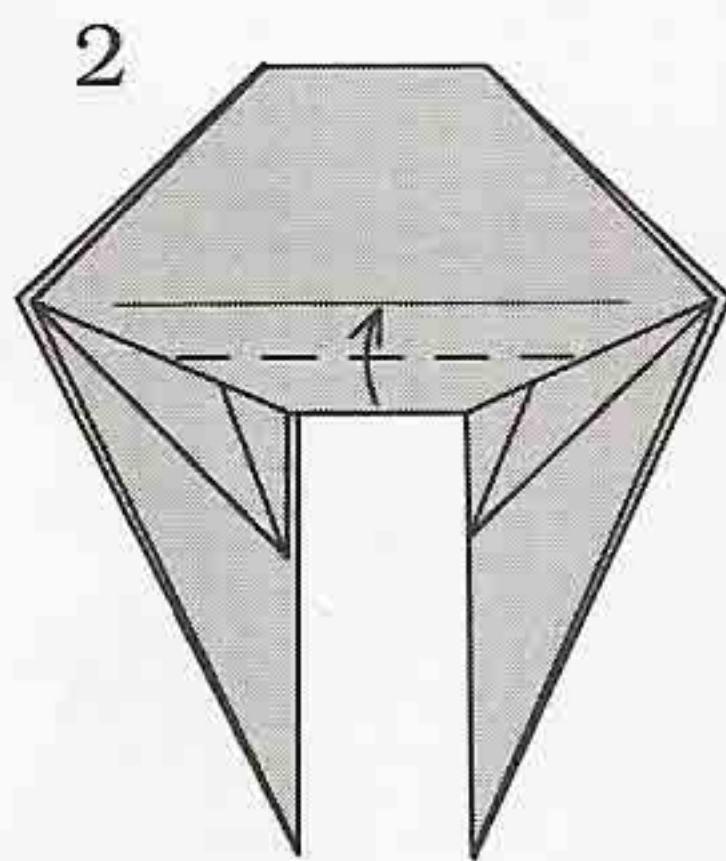

Repeat behind.

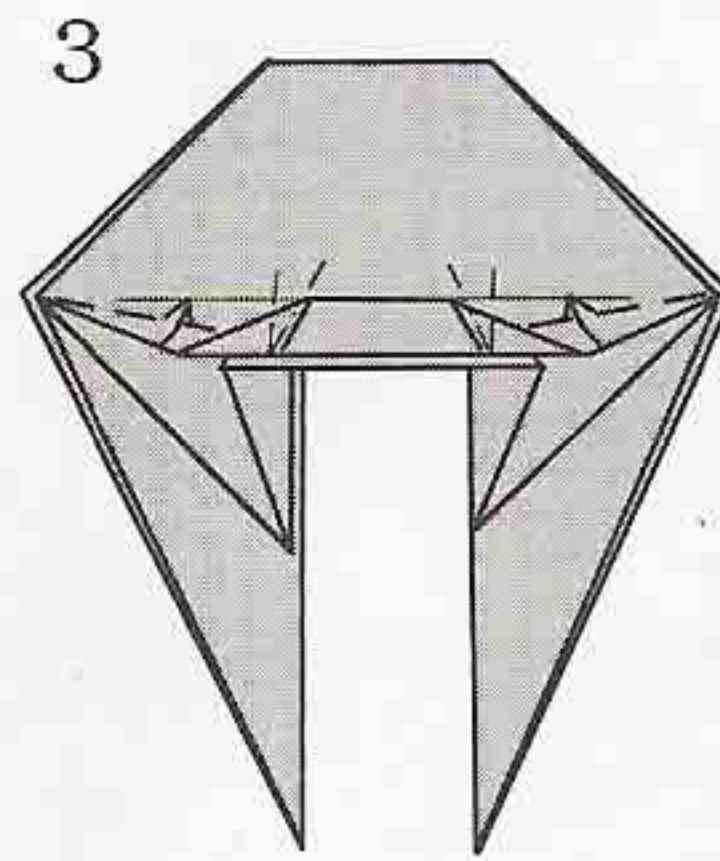

Repeat behind.

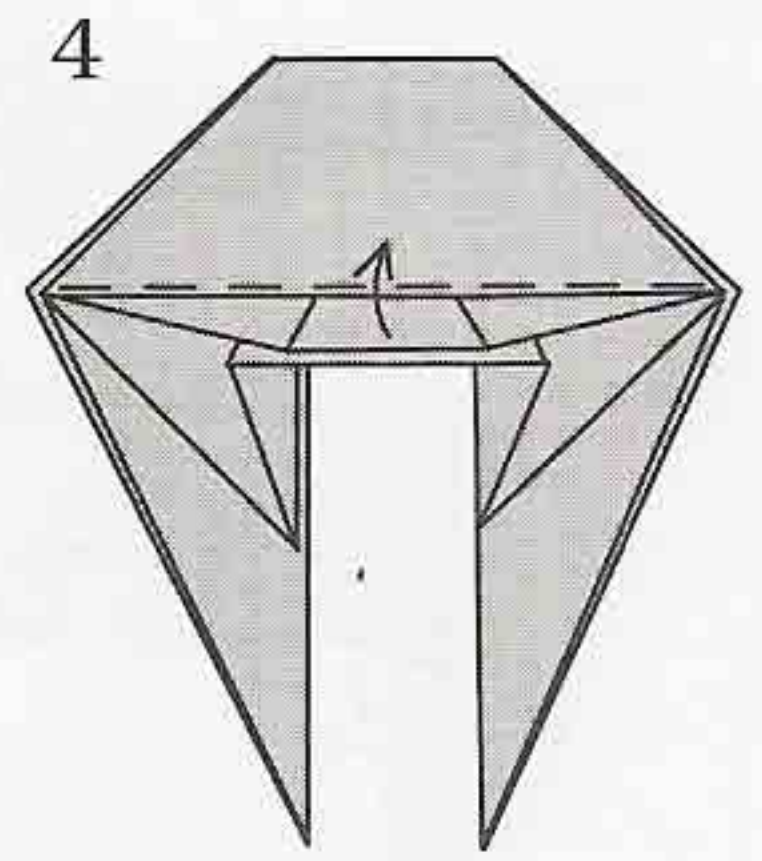

Repeat behind.

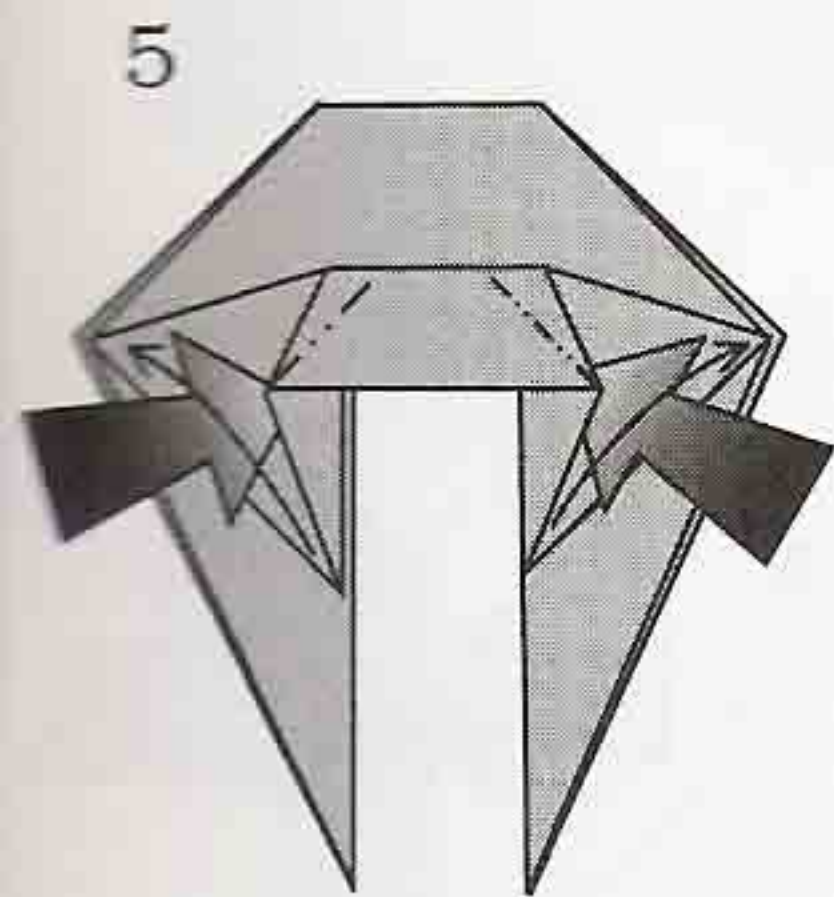

Reverse folds,
repeat behind.

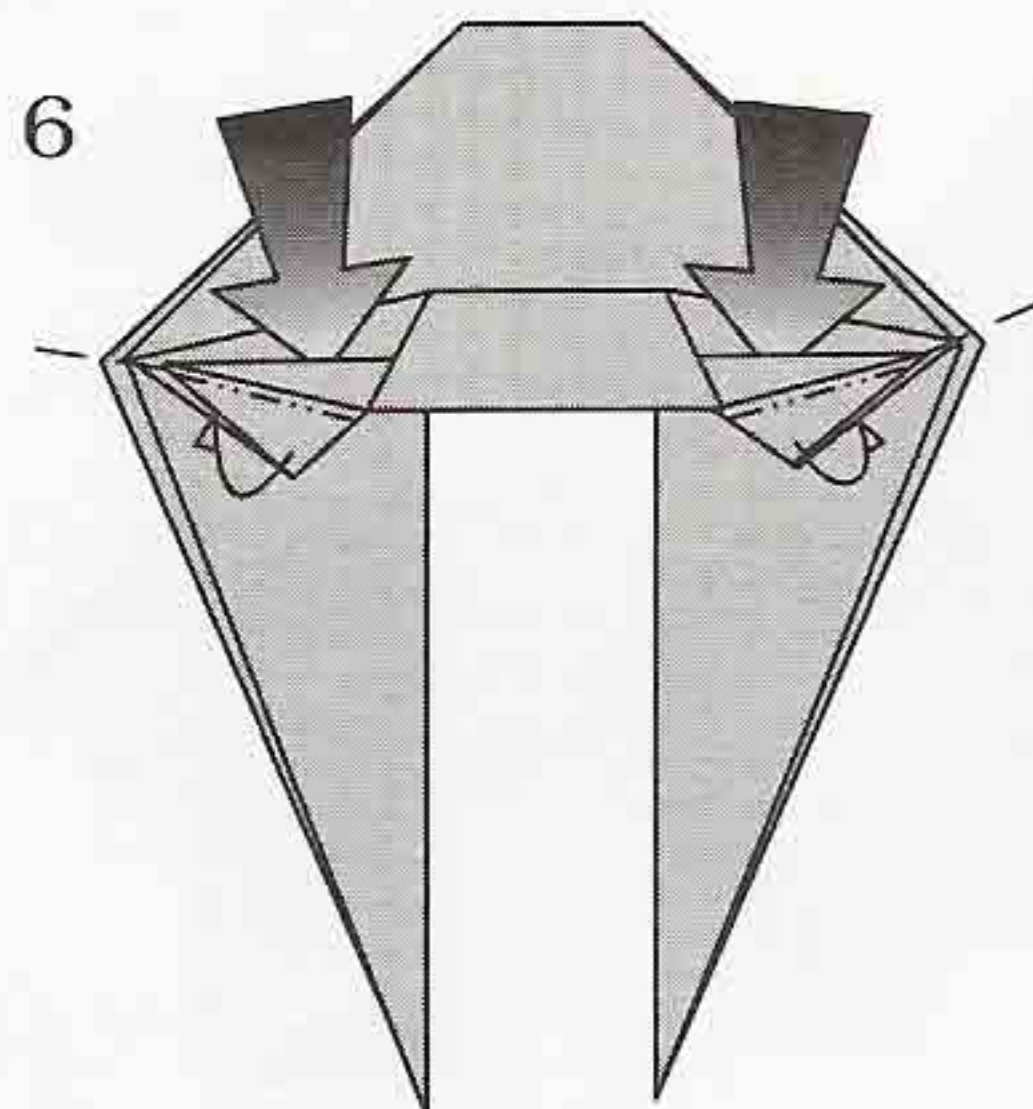

Reverse folds,
repeat behind.

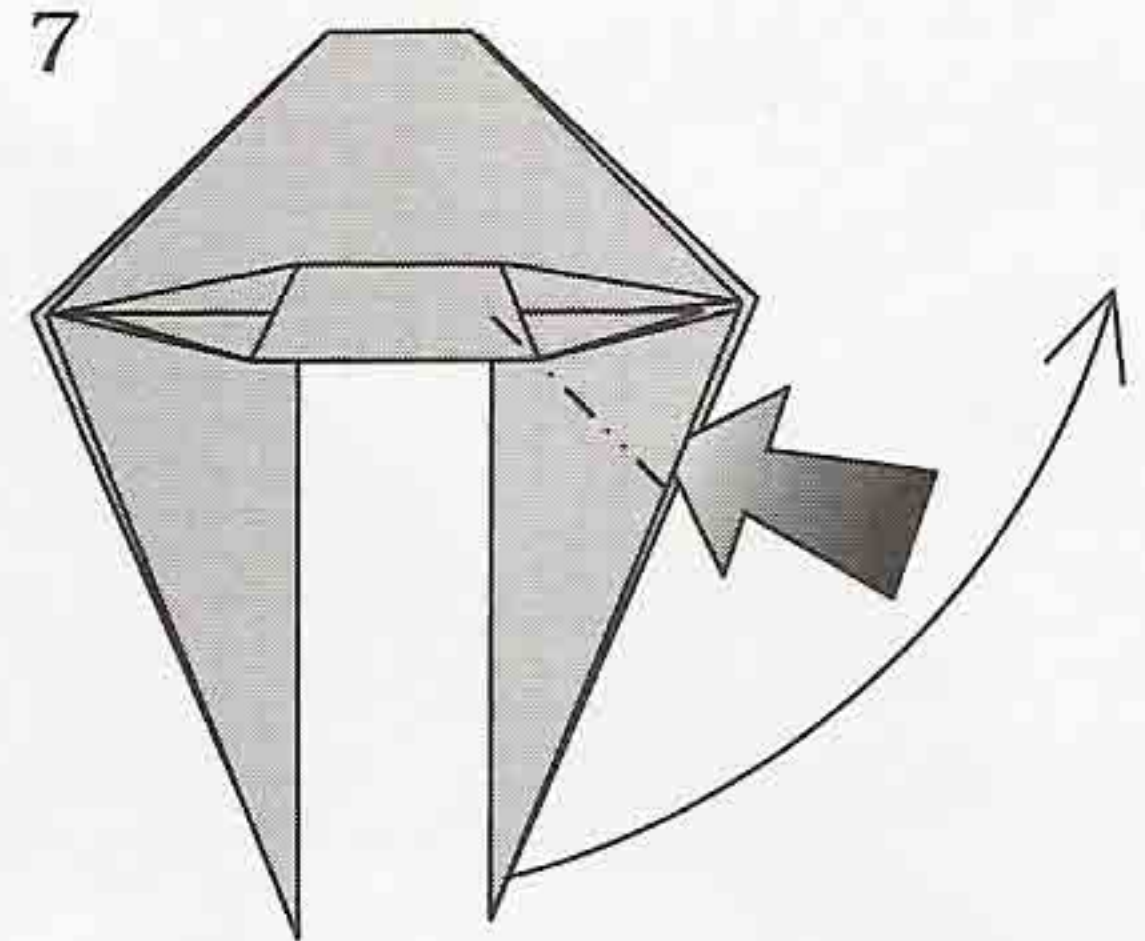

Reverse-fold.

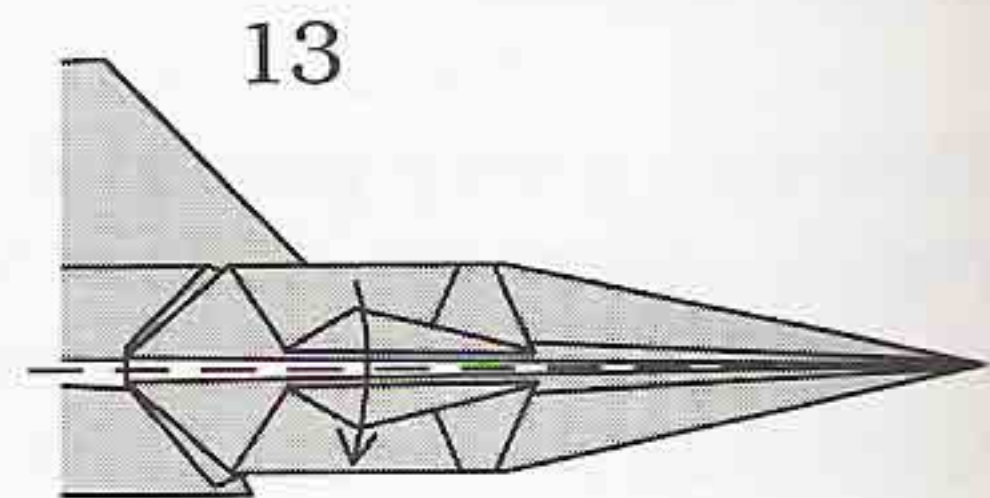
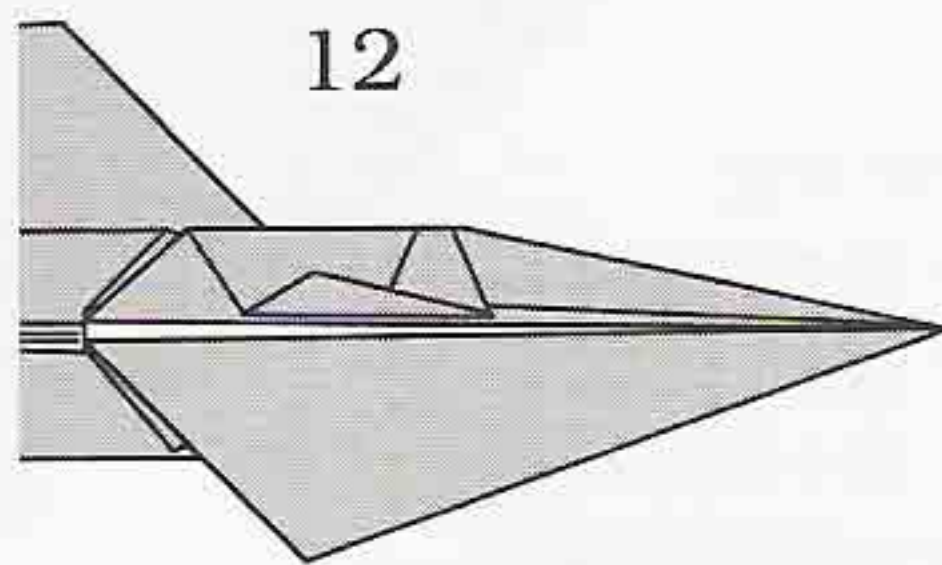
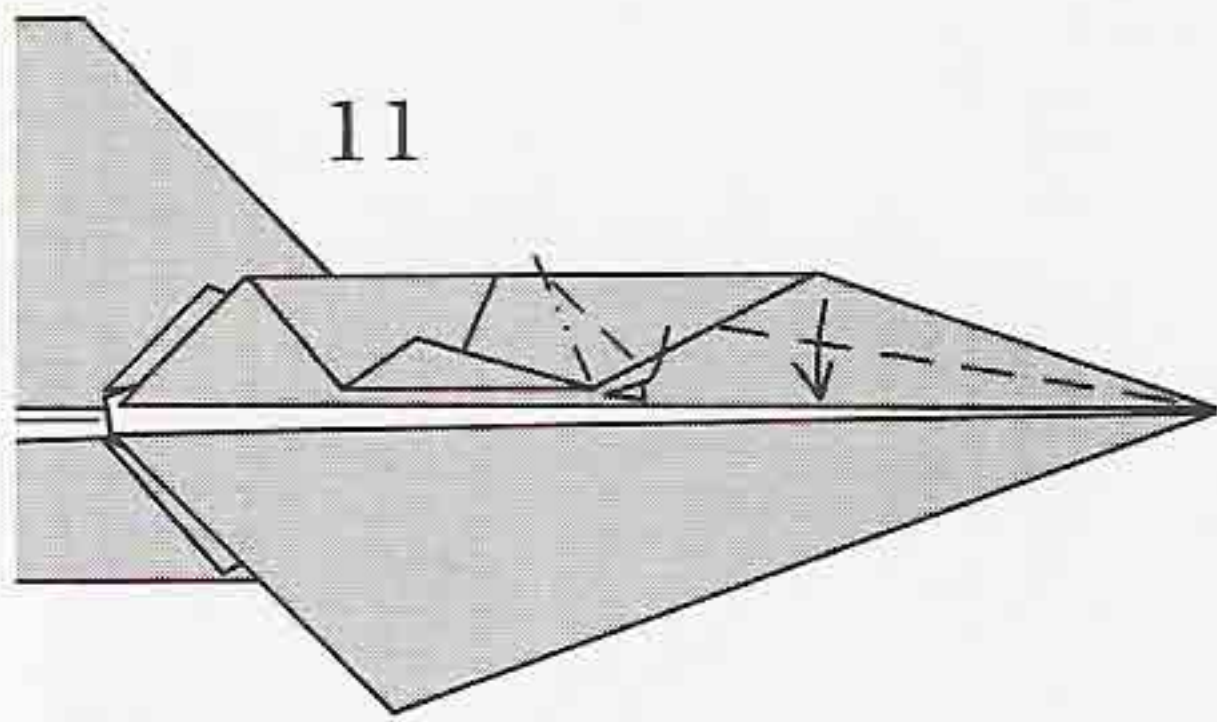
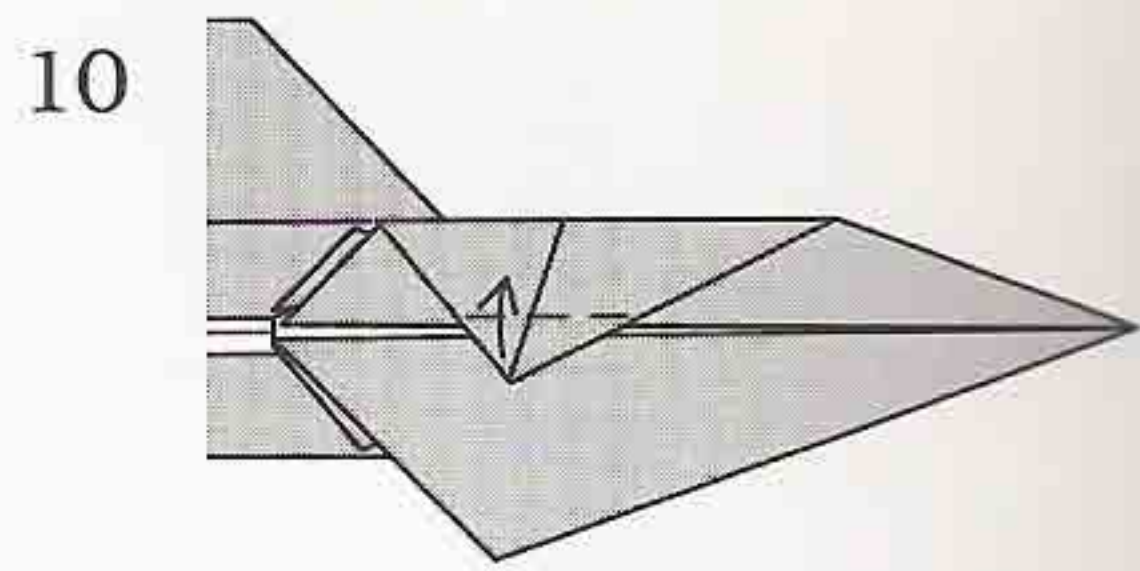
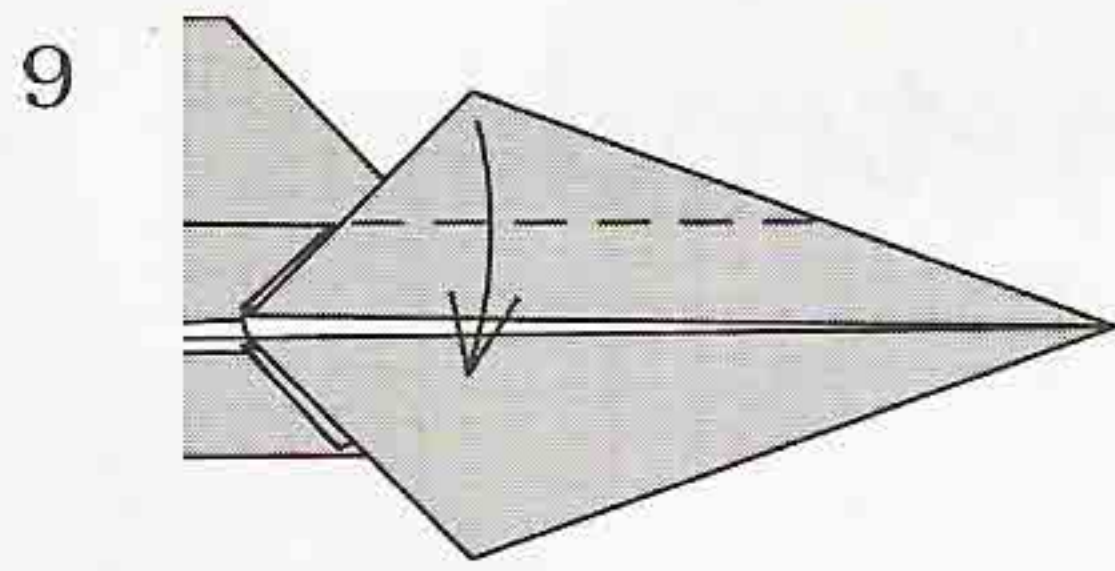
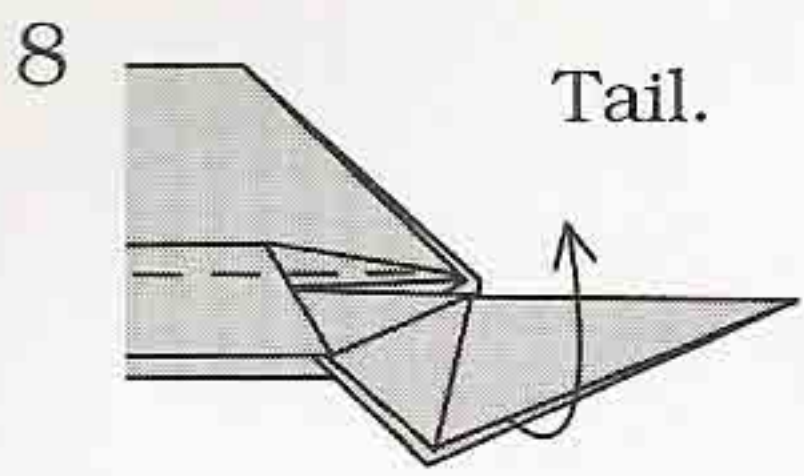

Repeat steps 9-11.

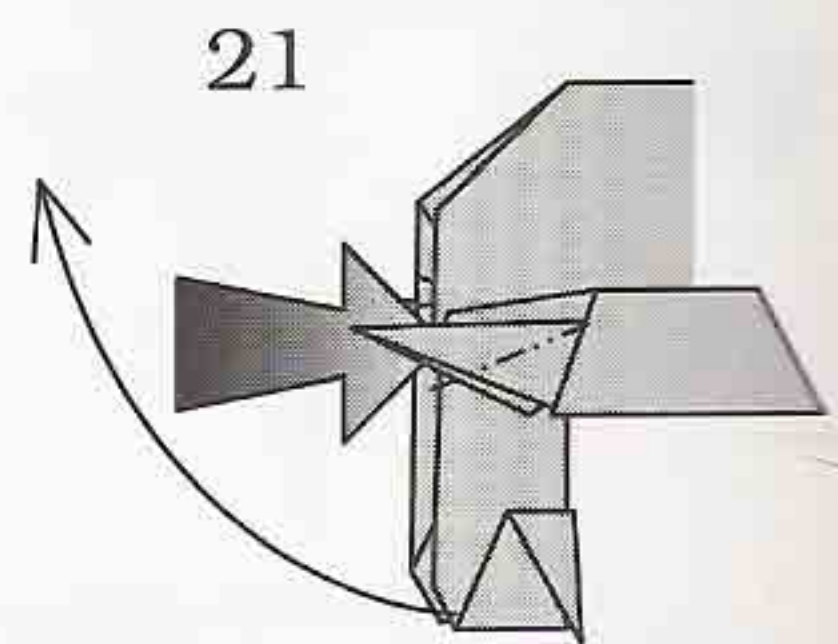
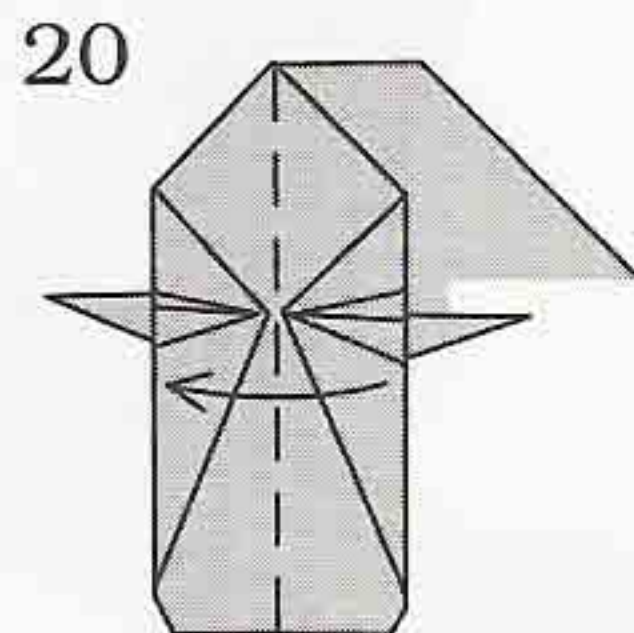
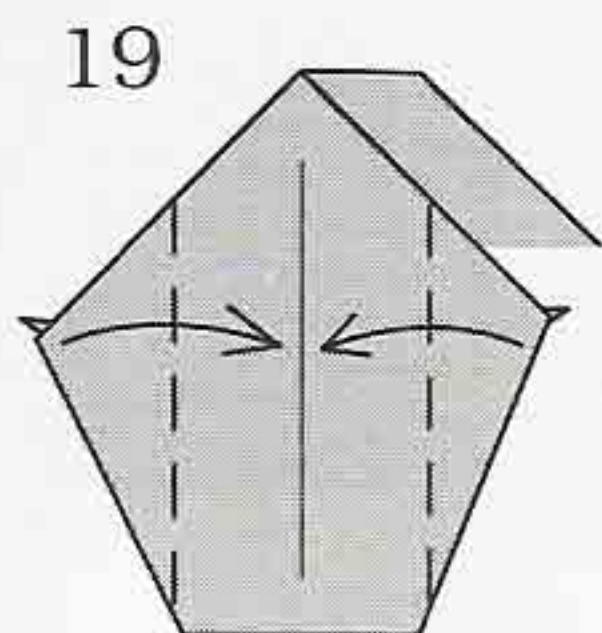
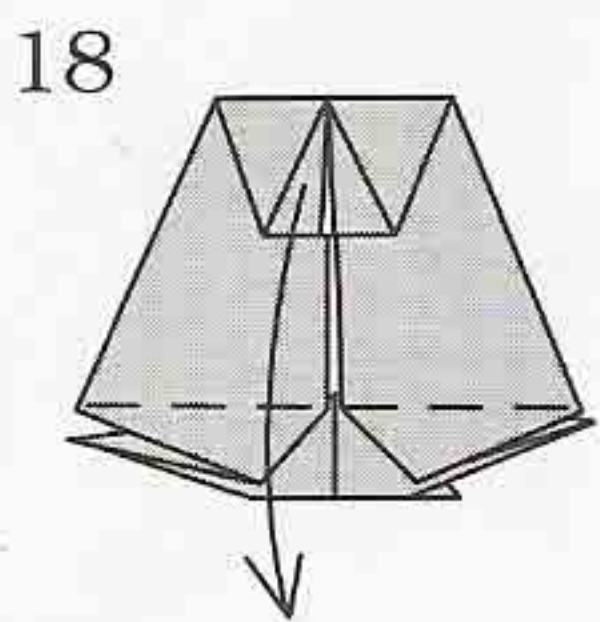
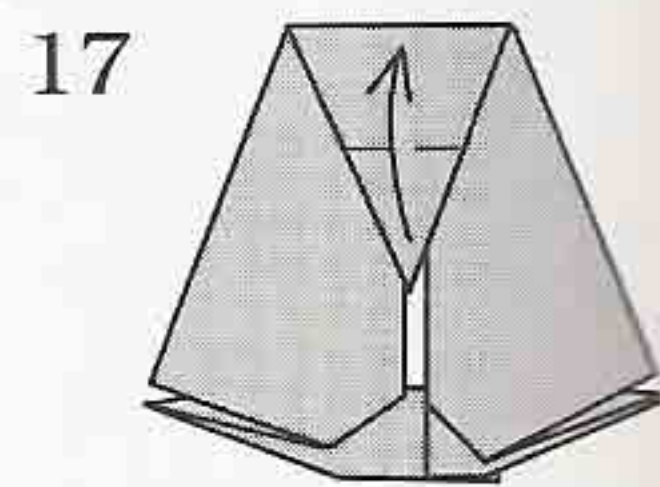
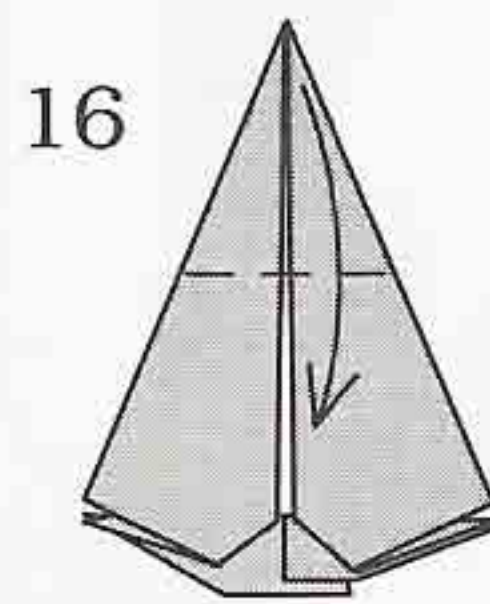
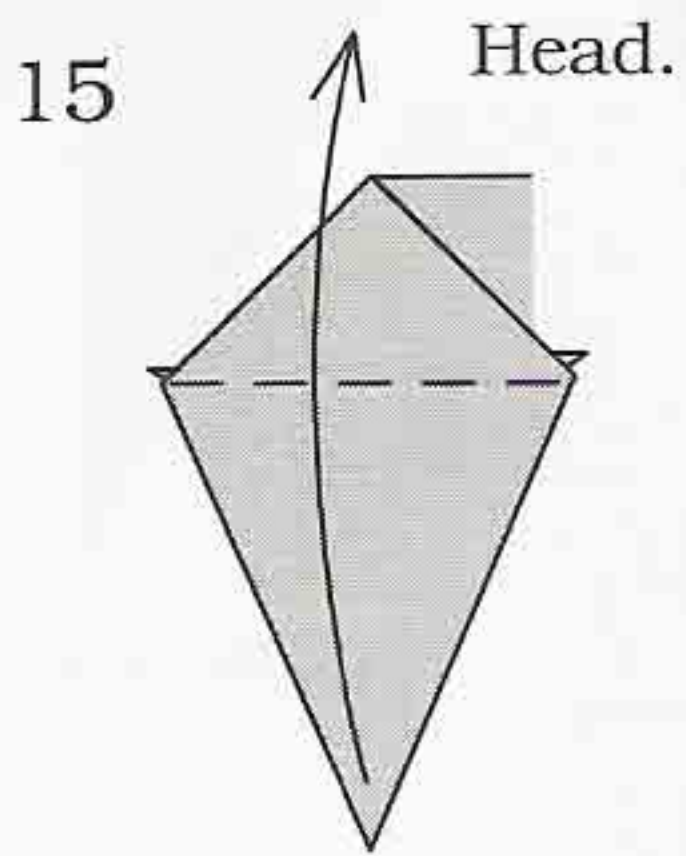
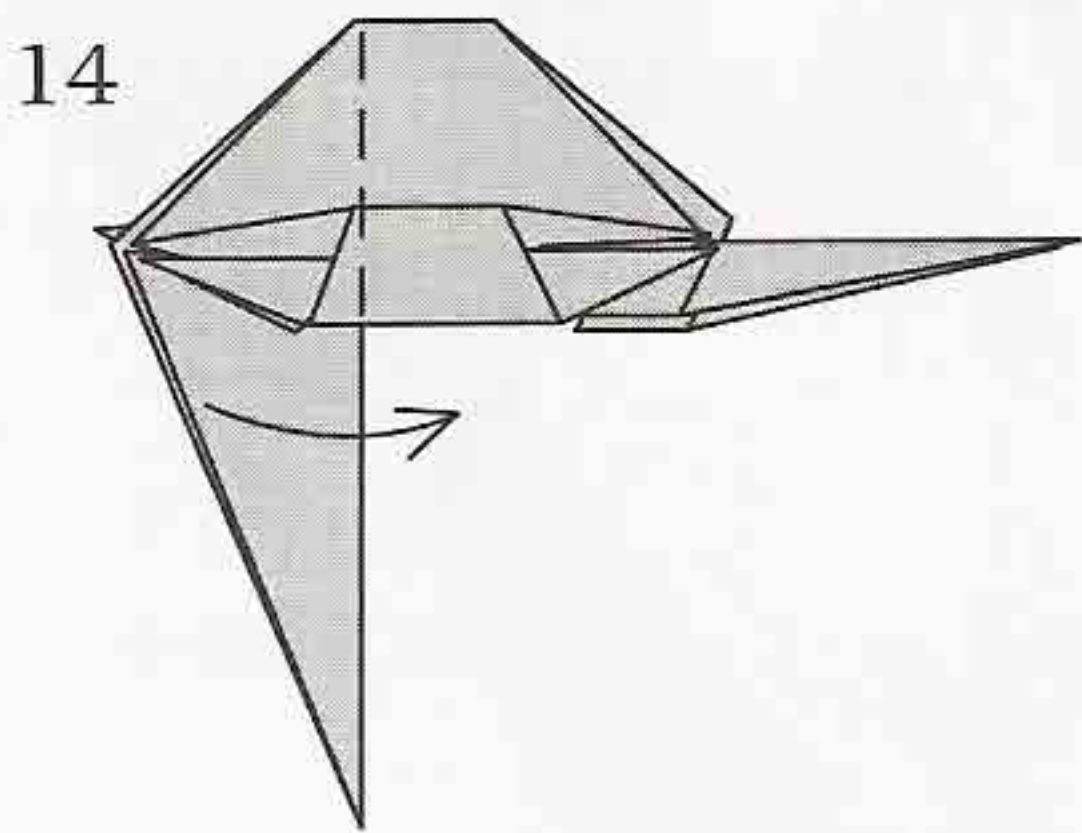

Reverse-fold.

22

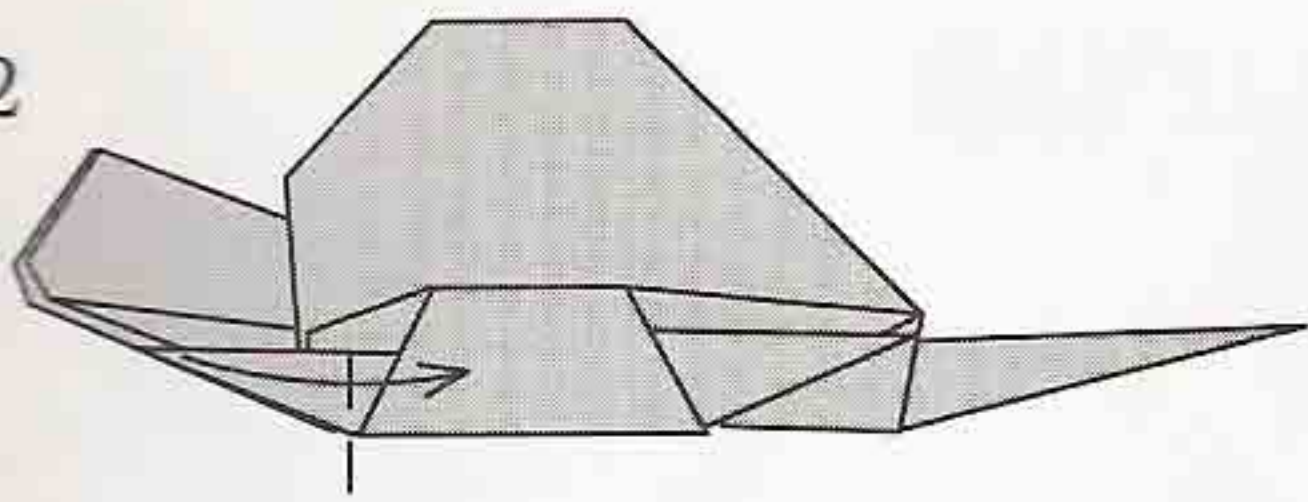

Repeat behind.

23

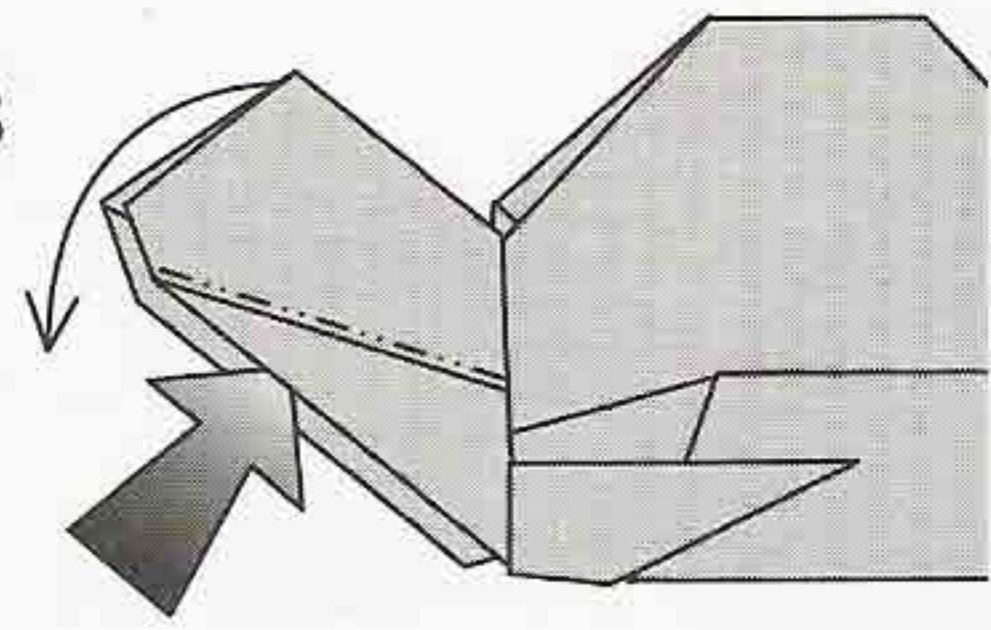

Reverse-fold.

24

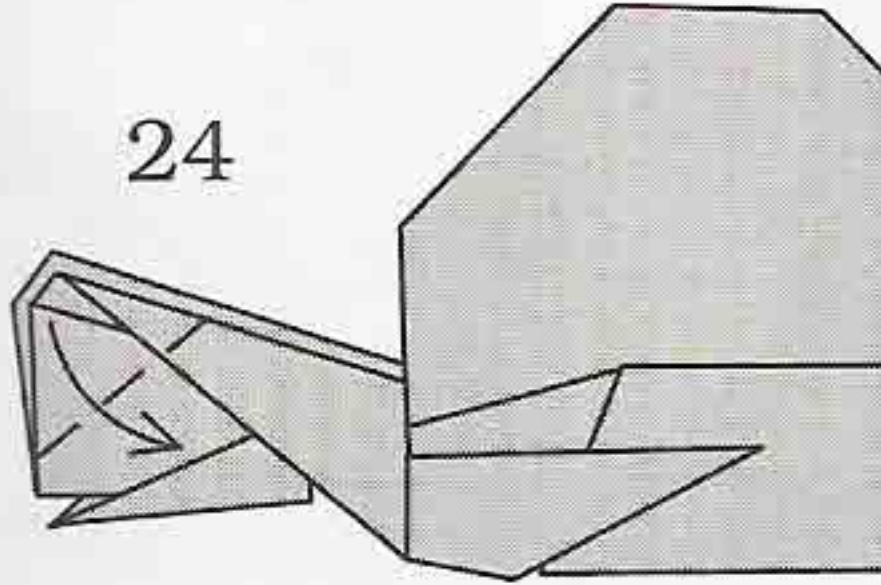

Repeat behind.

25

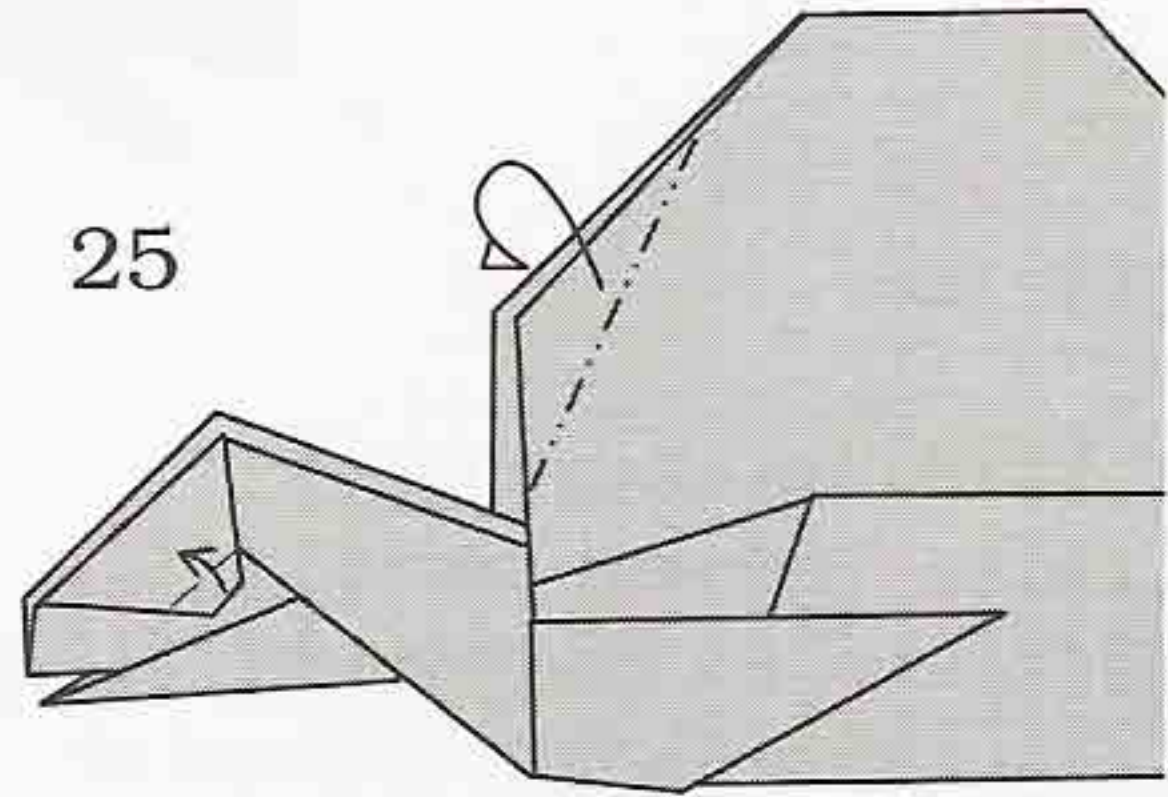

Form the eye and shape the back. Repeat behind.

26

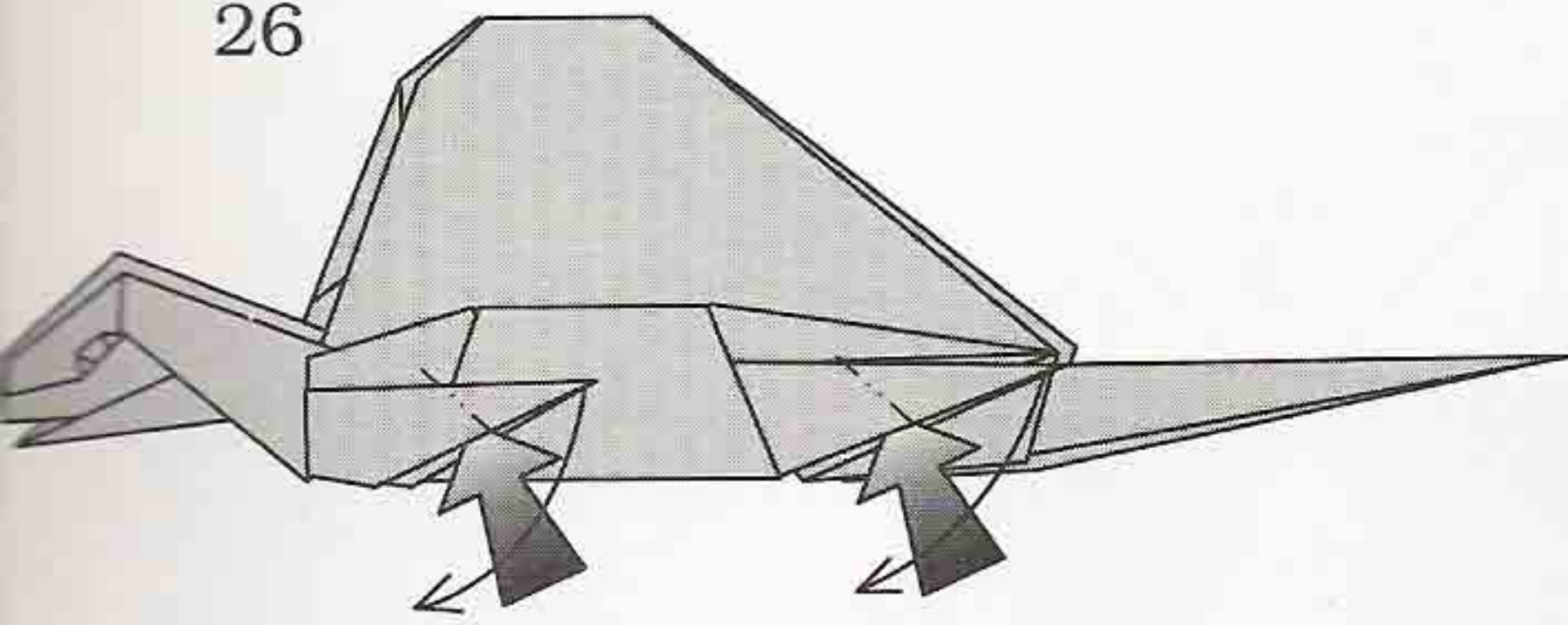

Reverse folds, repeat behind.

27

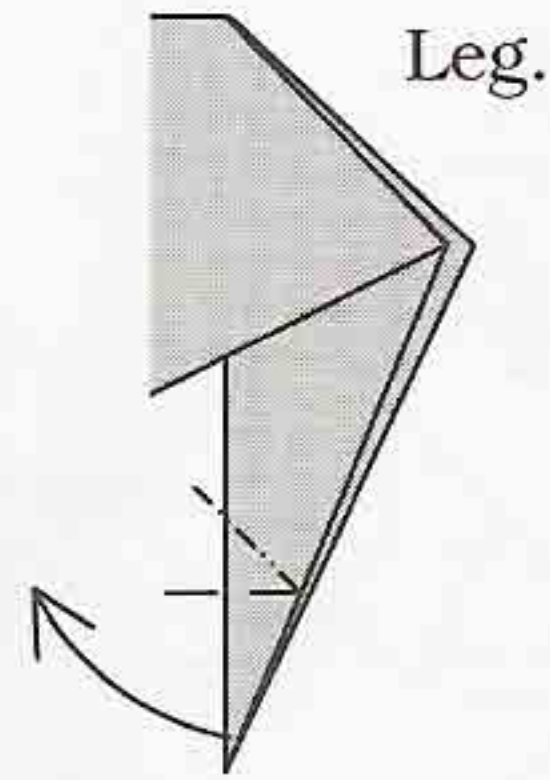

Leg.

Crimp-fold the four legs.

28

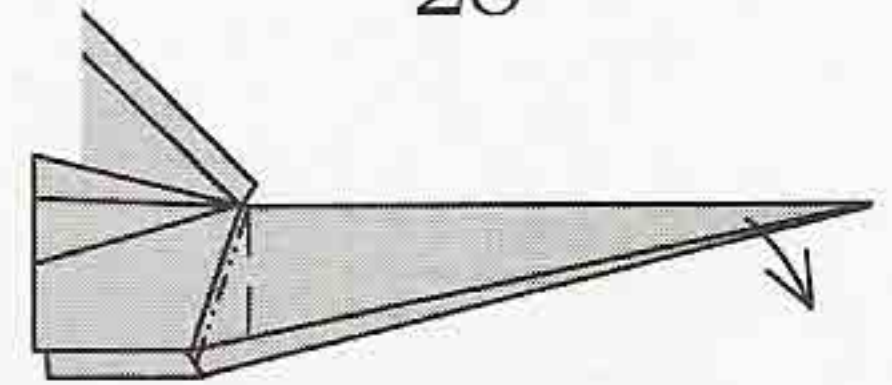

Crimp-fold and curl the tail.

29

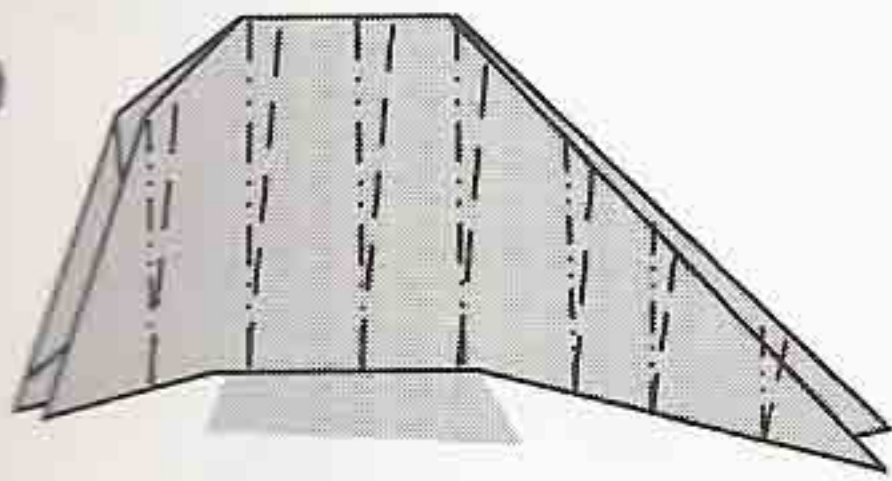

Pleat Dimetrodon's sail.

30

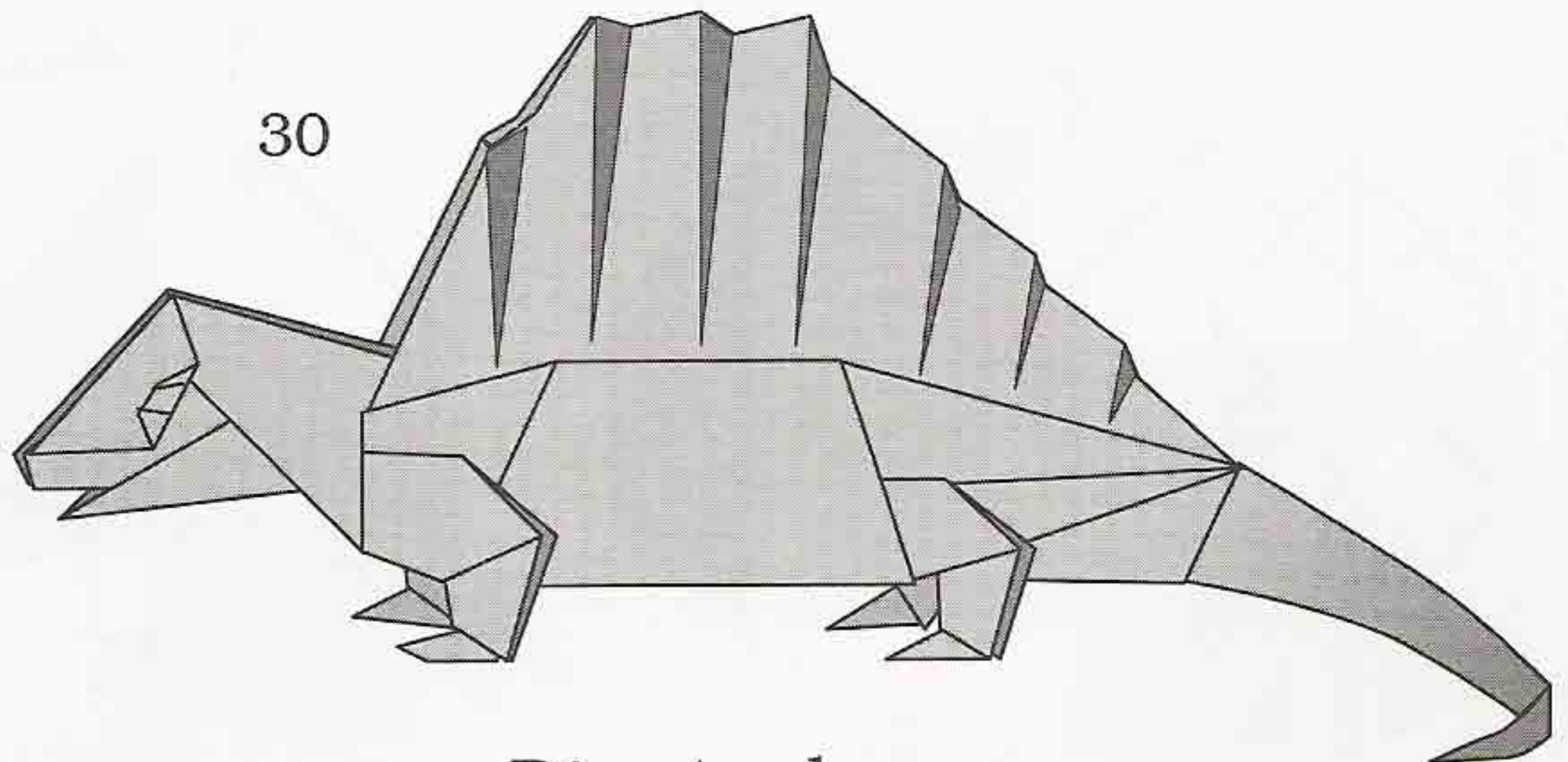

Dimetrodon

Elasmosaurus

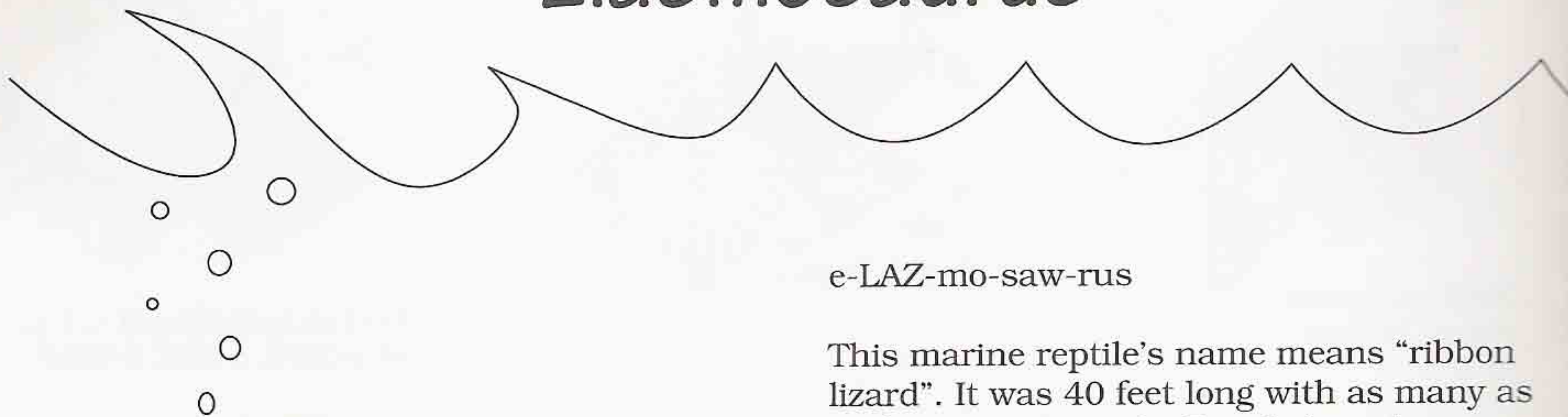

e-LAZ-mo-saw-rus

This marine reptile's name means "ribbon lizard". It was 40 feet long with as many as 76 bones in its neck. Fossils have been found in Kansas which was a shallow sea in the Cretaceous Period. It used its long neck and sharp teeth to dine on fish.

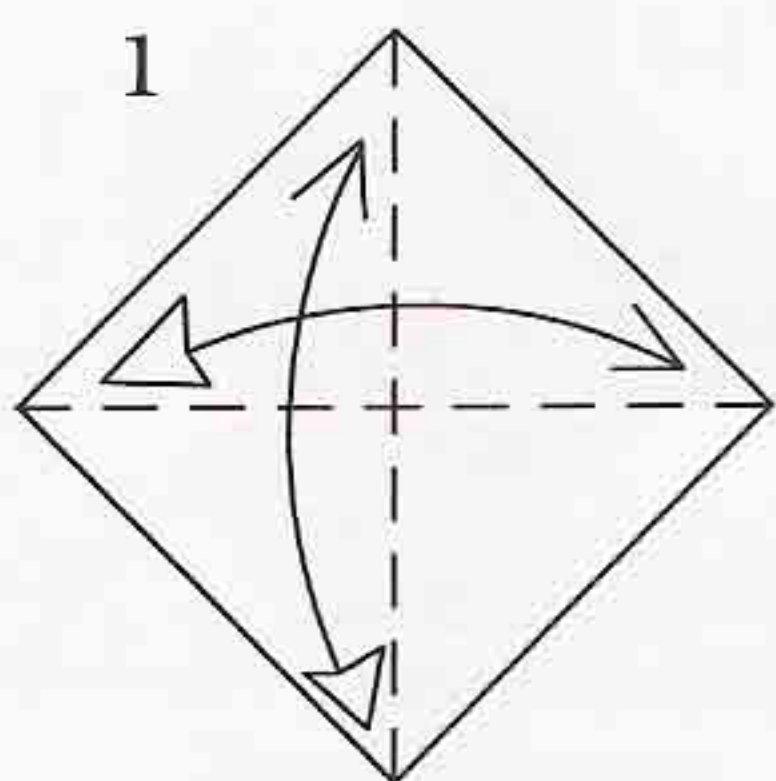
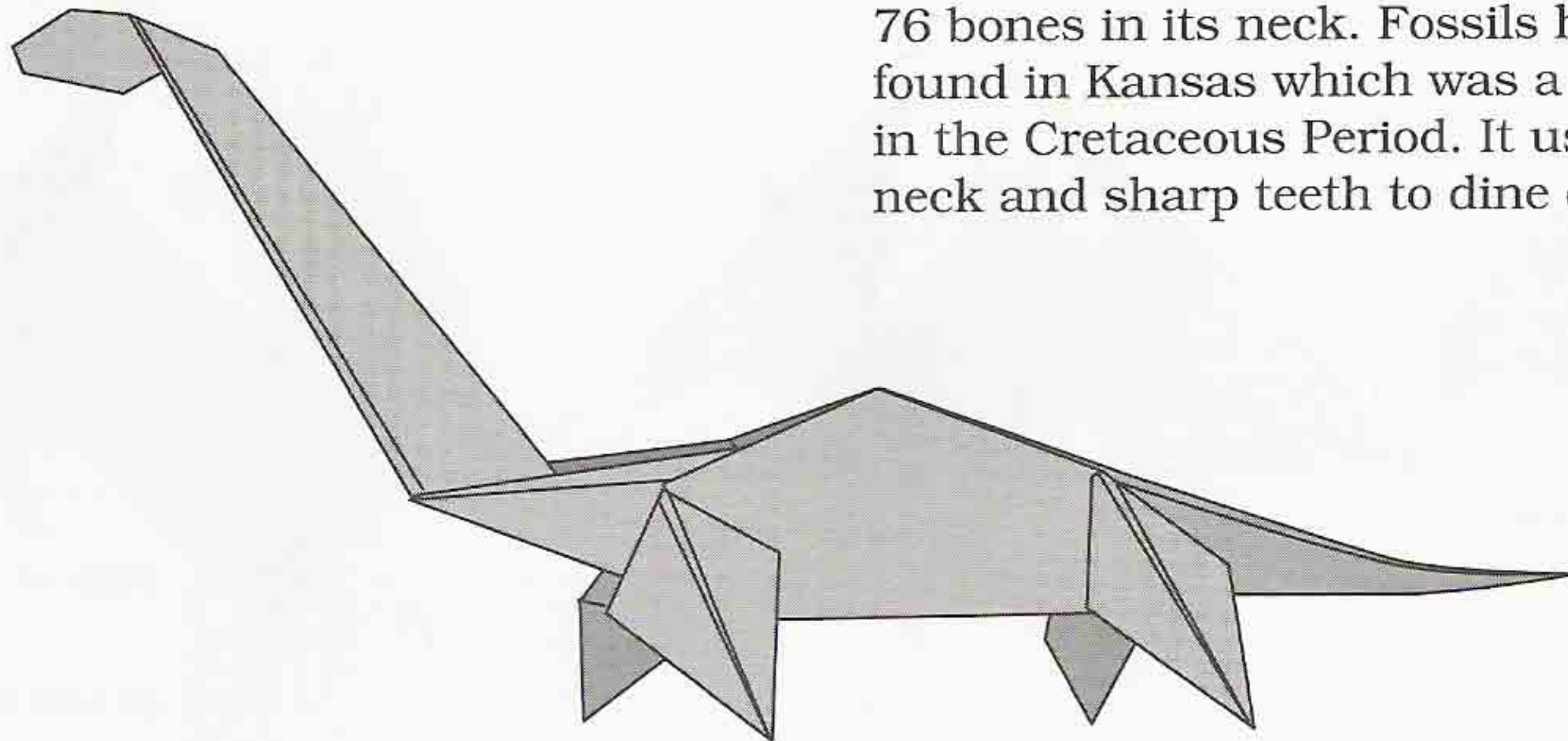

1
Fold and unfold along the diagonals.

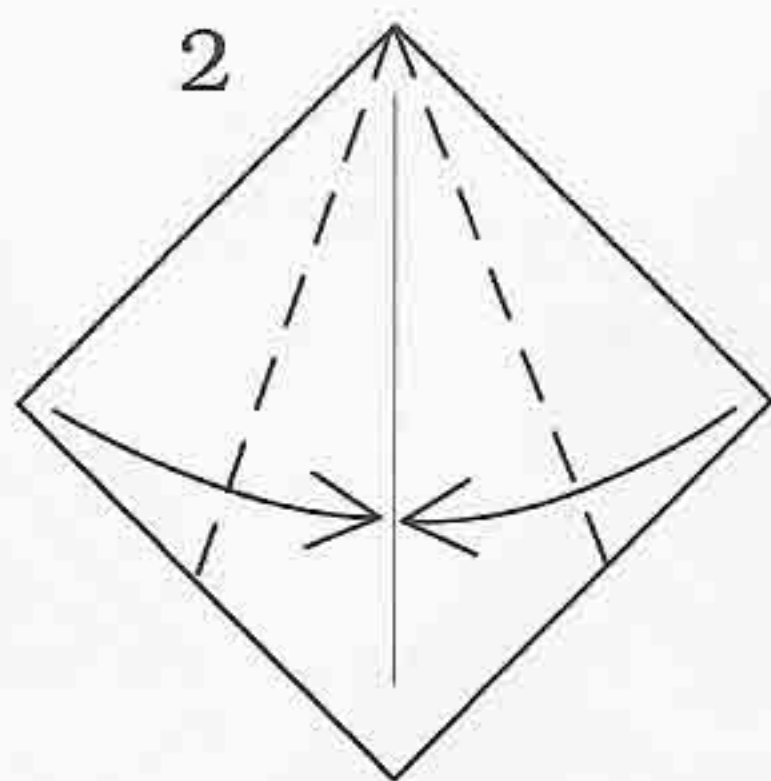

2
Kite-fold.

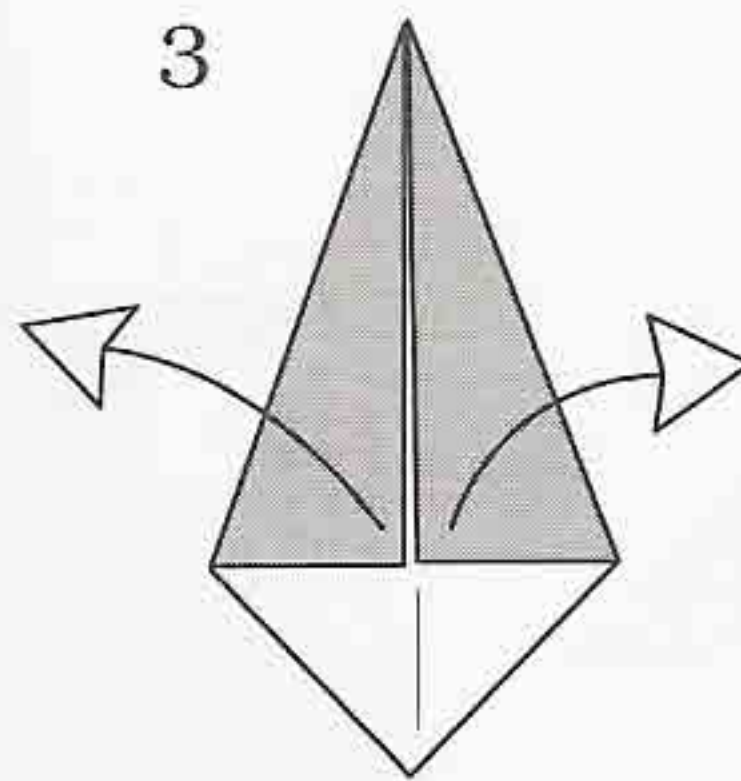

3
Unfold.

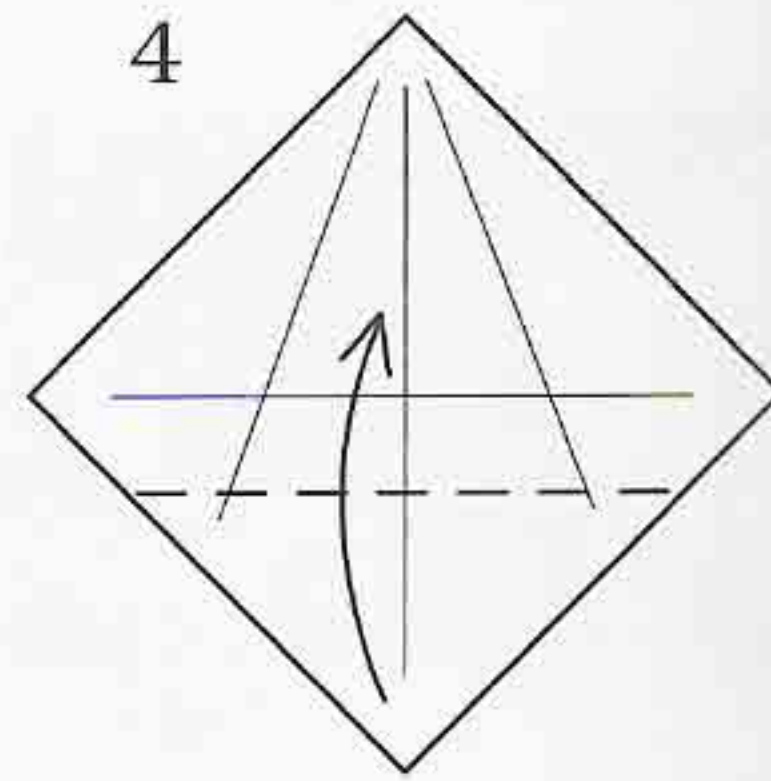

4
Fold and unfold.

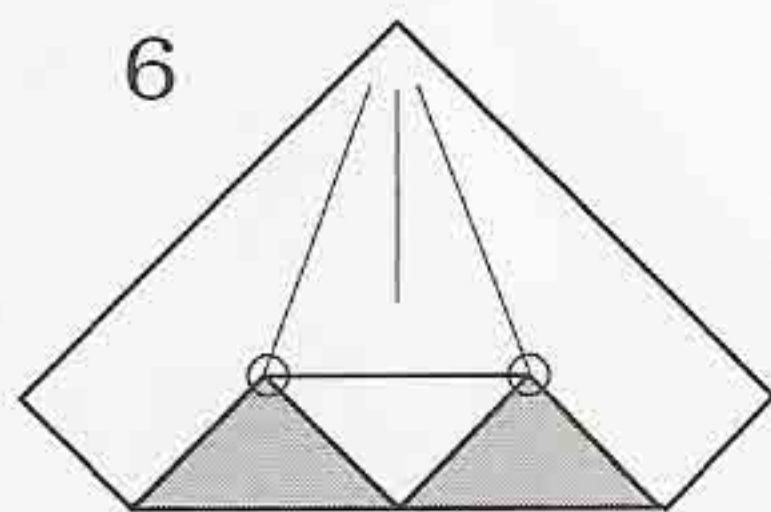
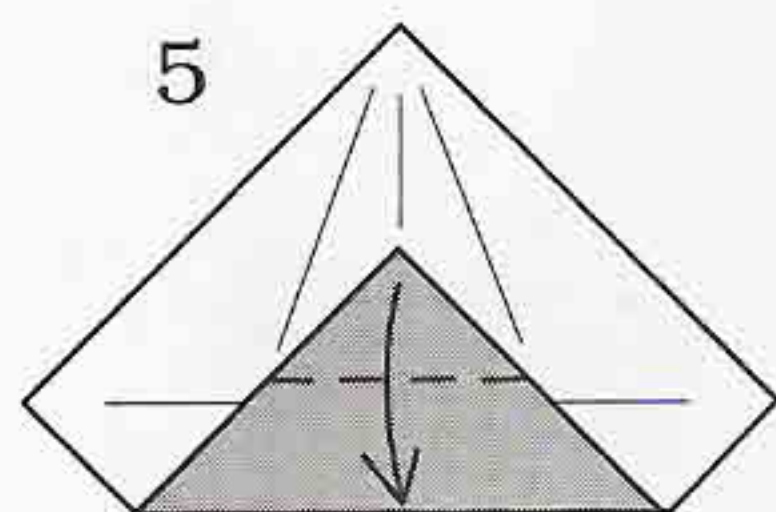

5
6
If all the lines intersect where the circles are drawn then continue. Otherwise, repeat steps 4-5.

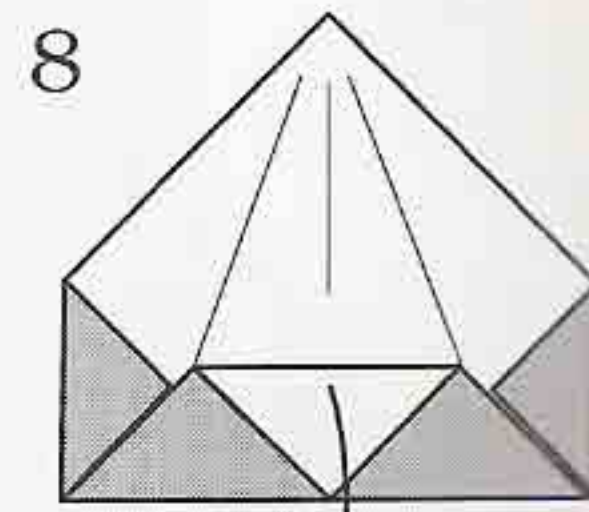
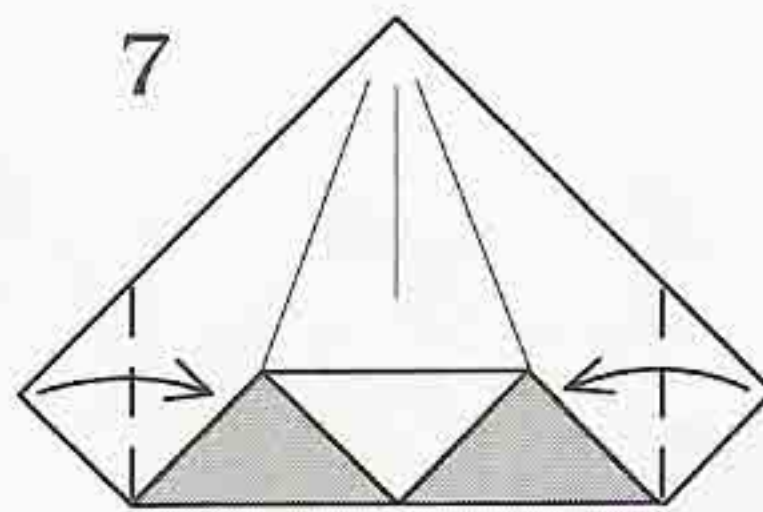

7
8
Unfold.

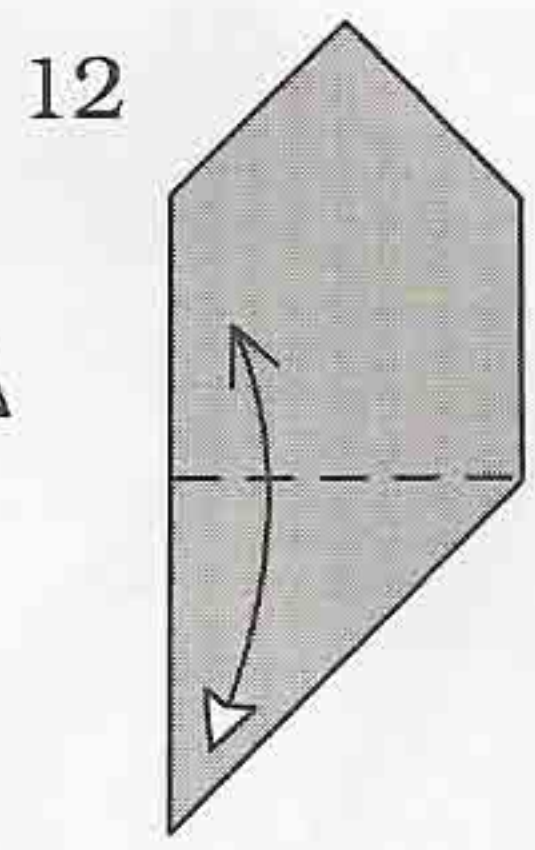
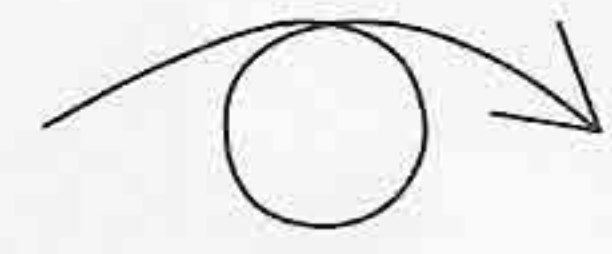
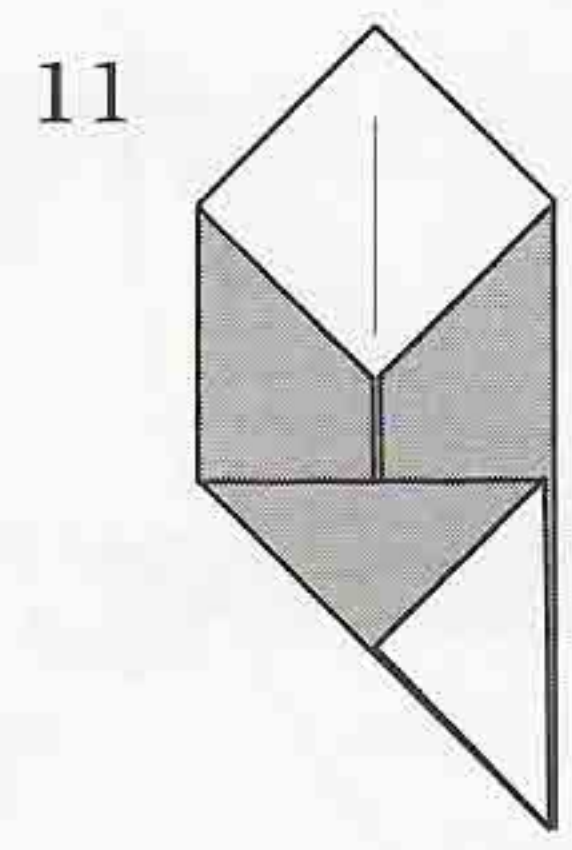
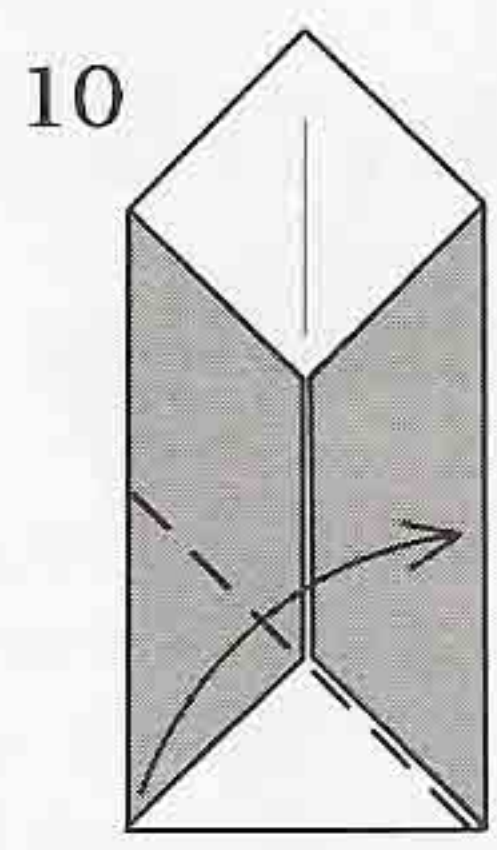
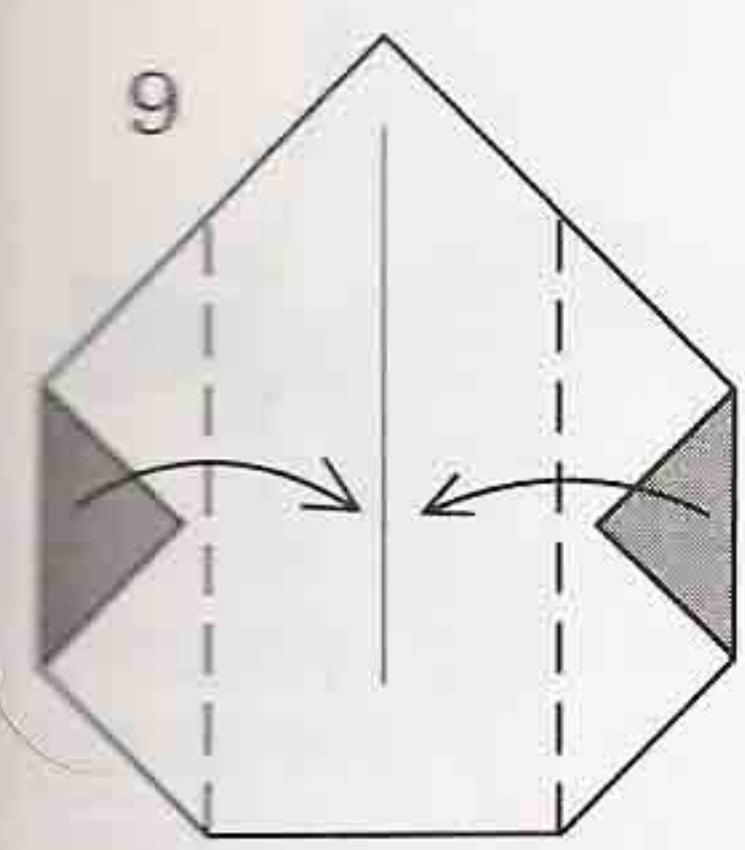

Fold up and unfold.

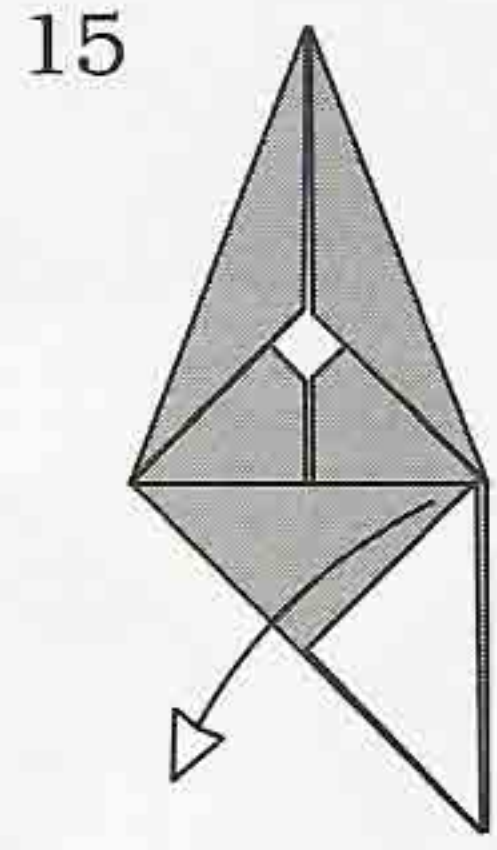
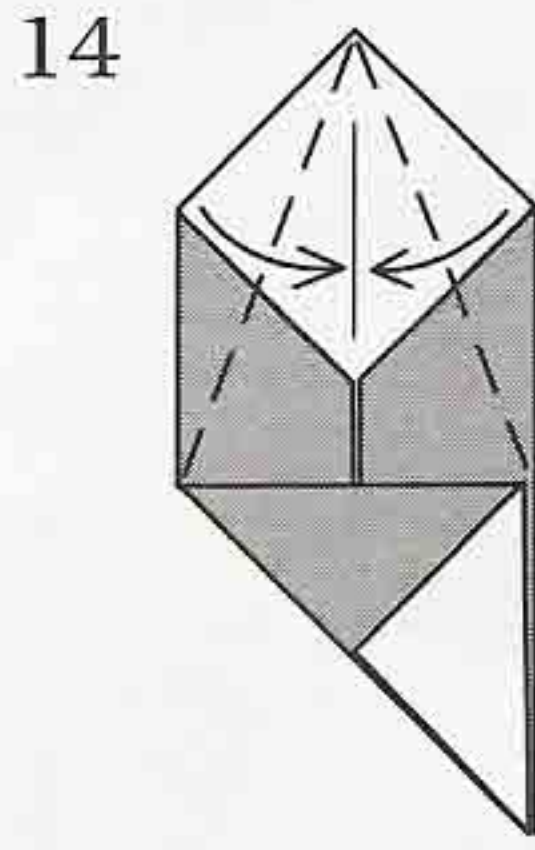
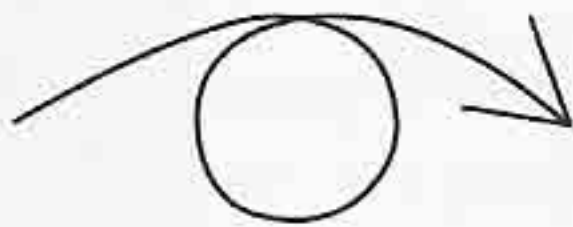
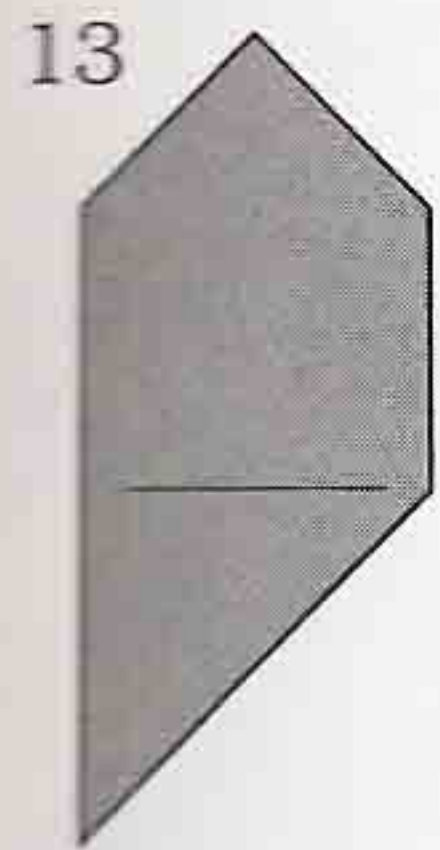

Unfold.

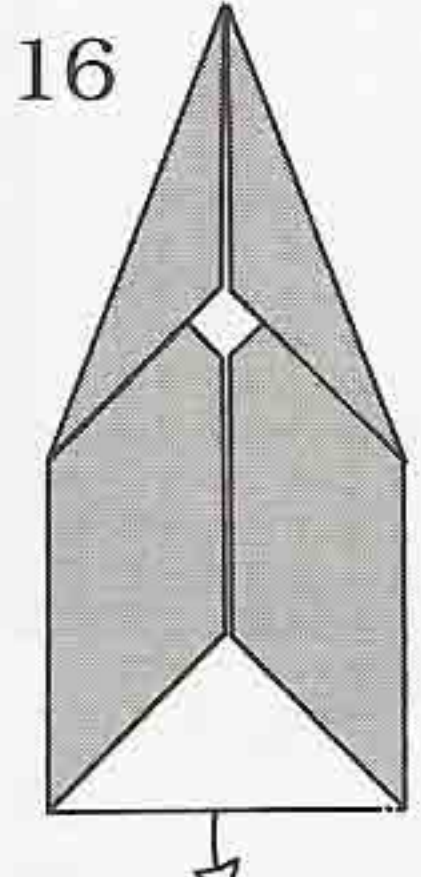

Unfold.

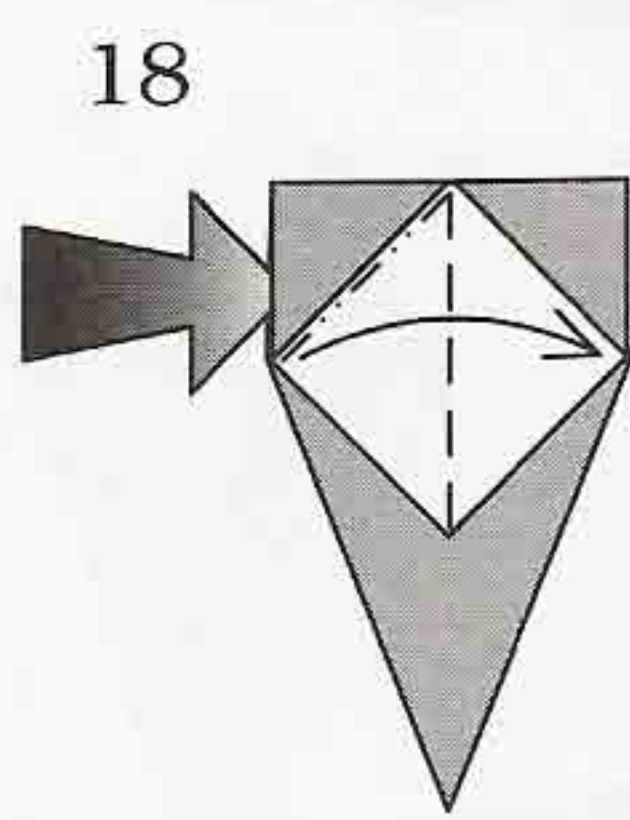
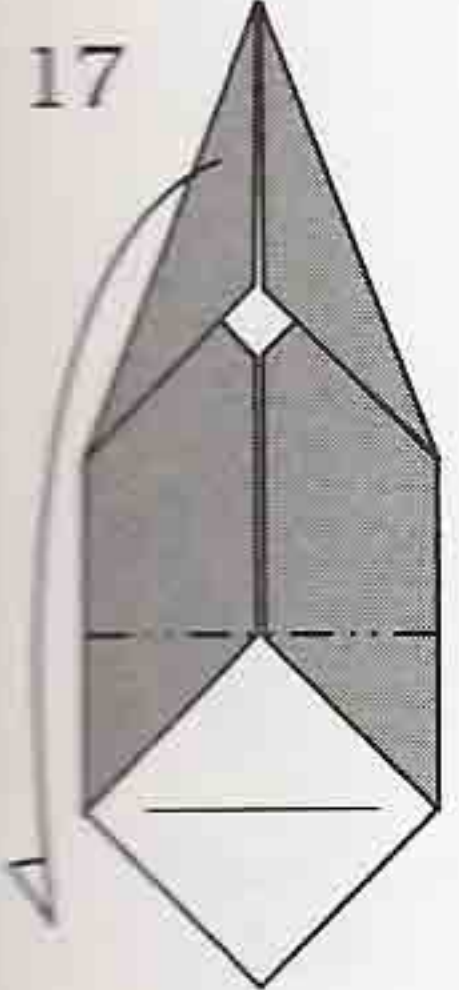

Squash-fold.

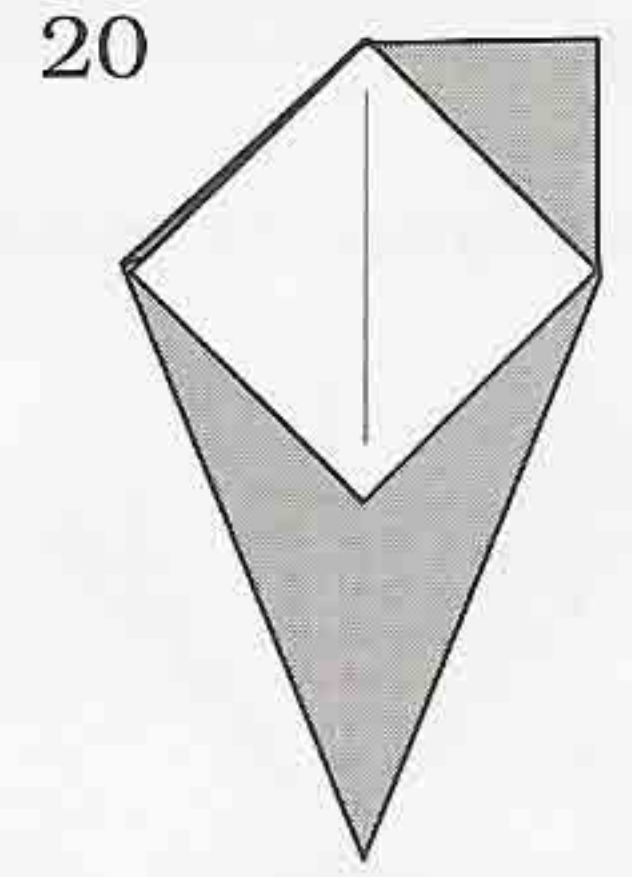
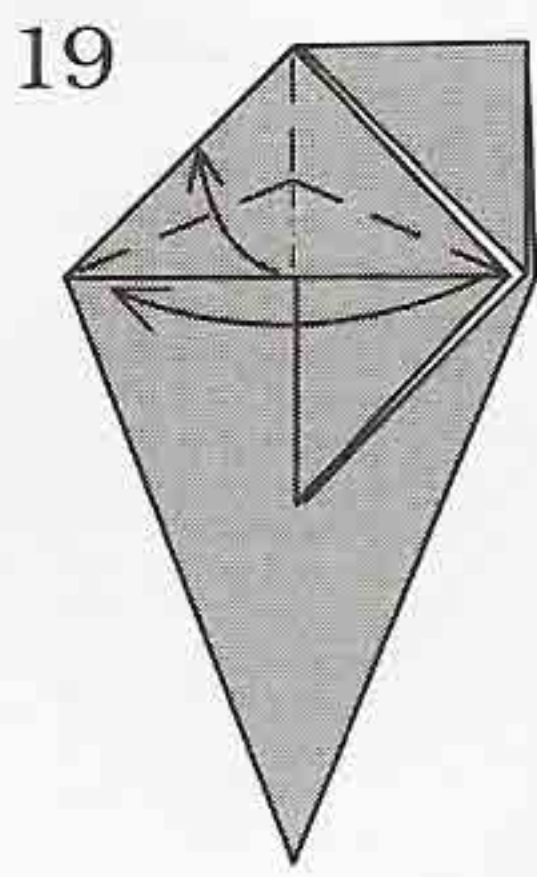

Repeat steps 18-19 on the right.

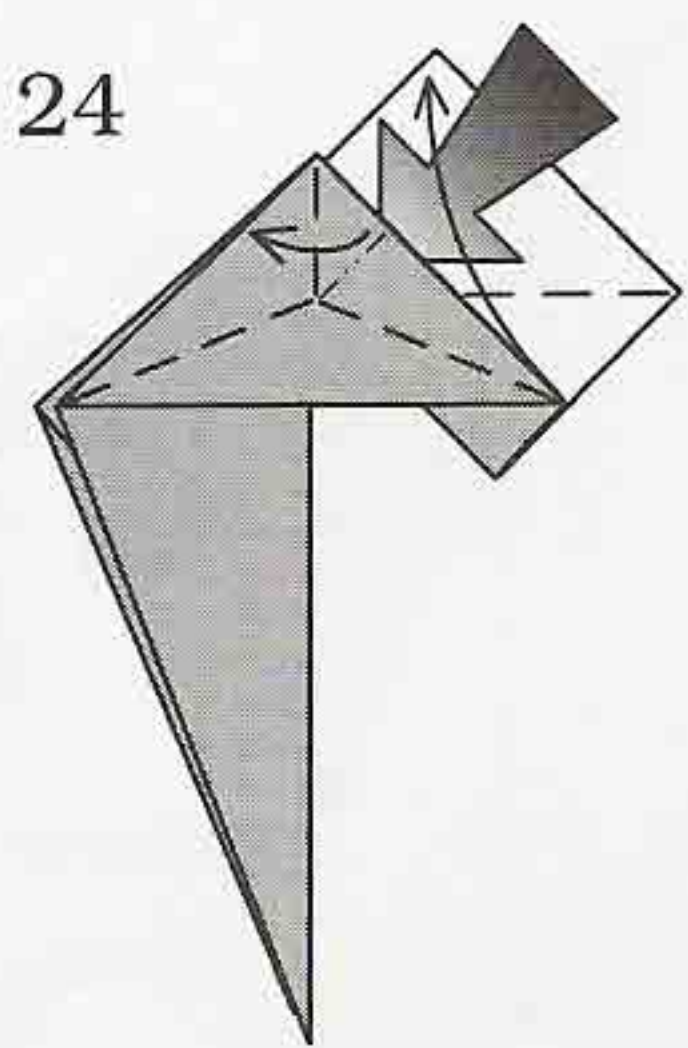
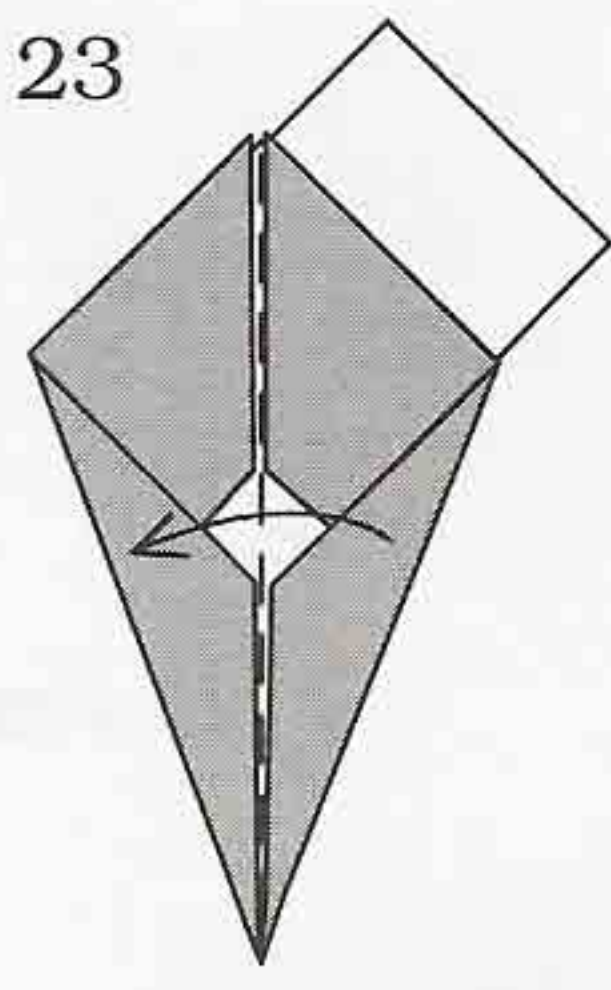
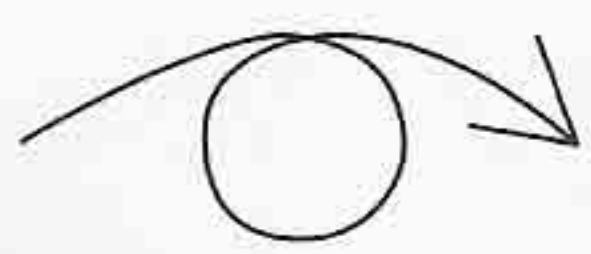
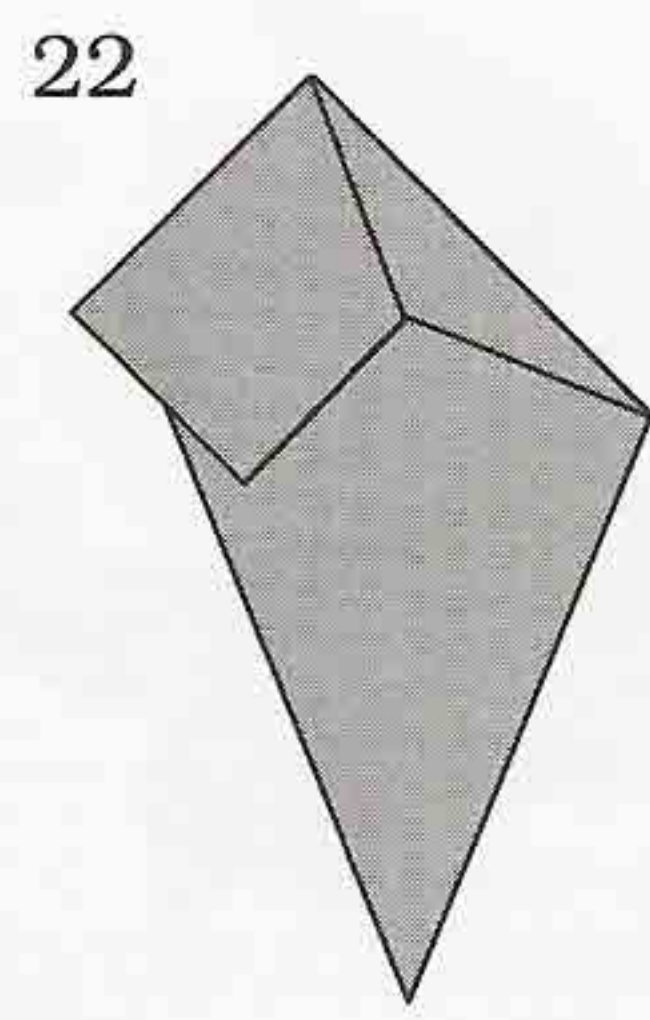
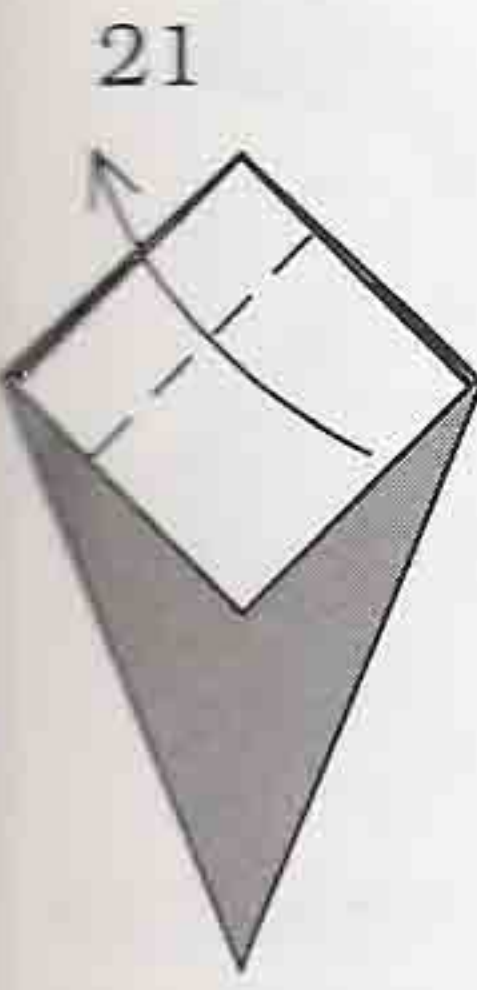

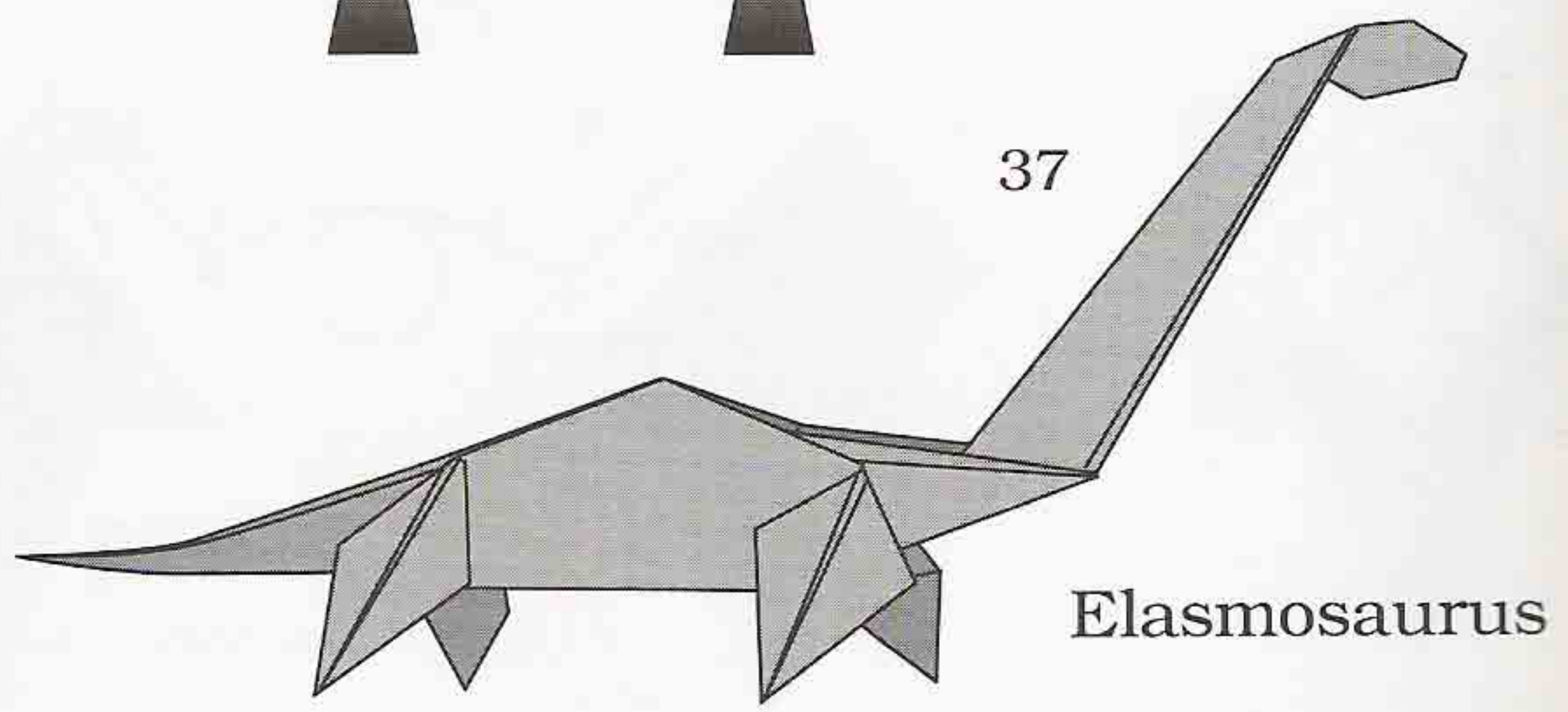
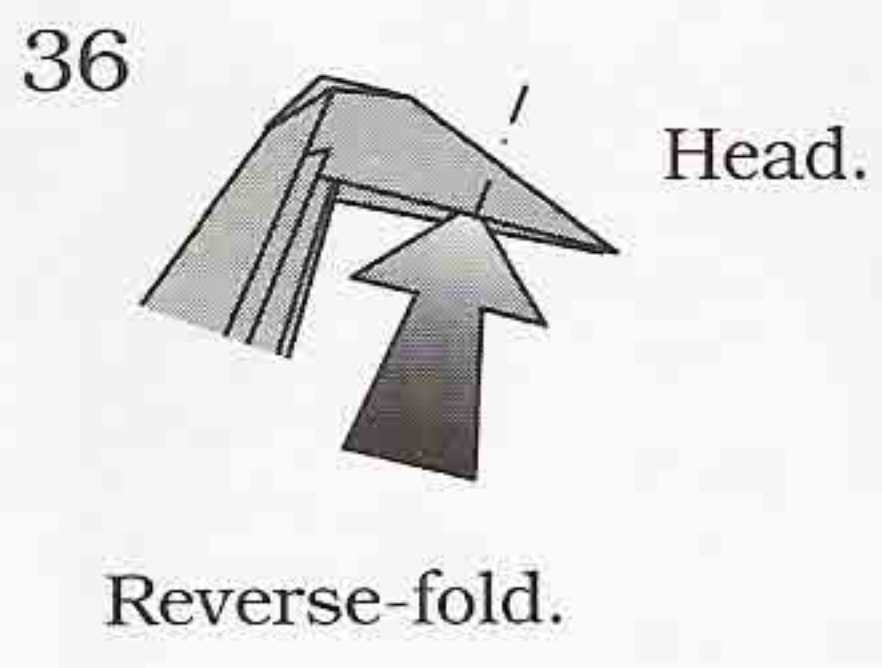
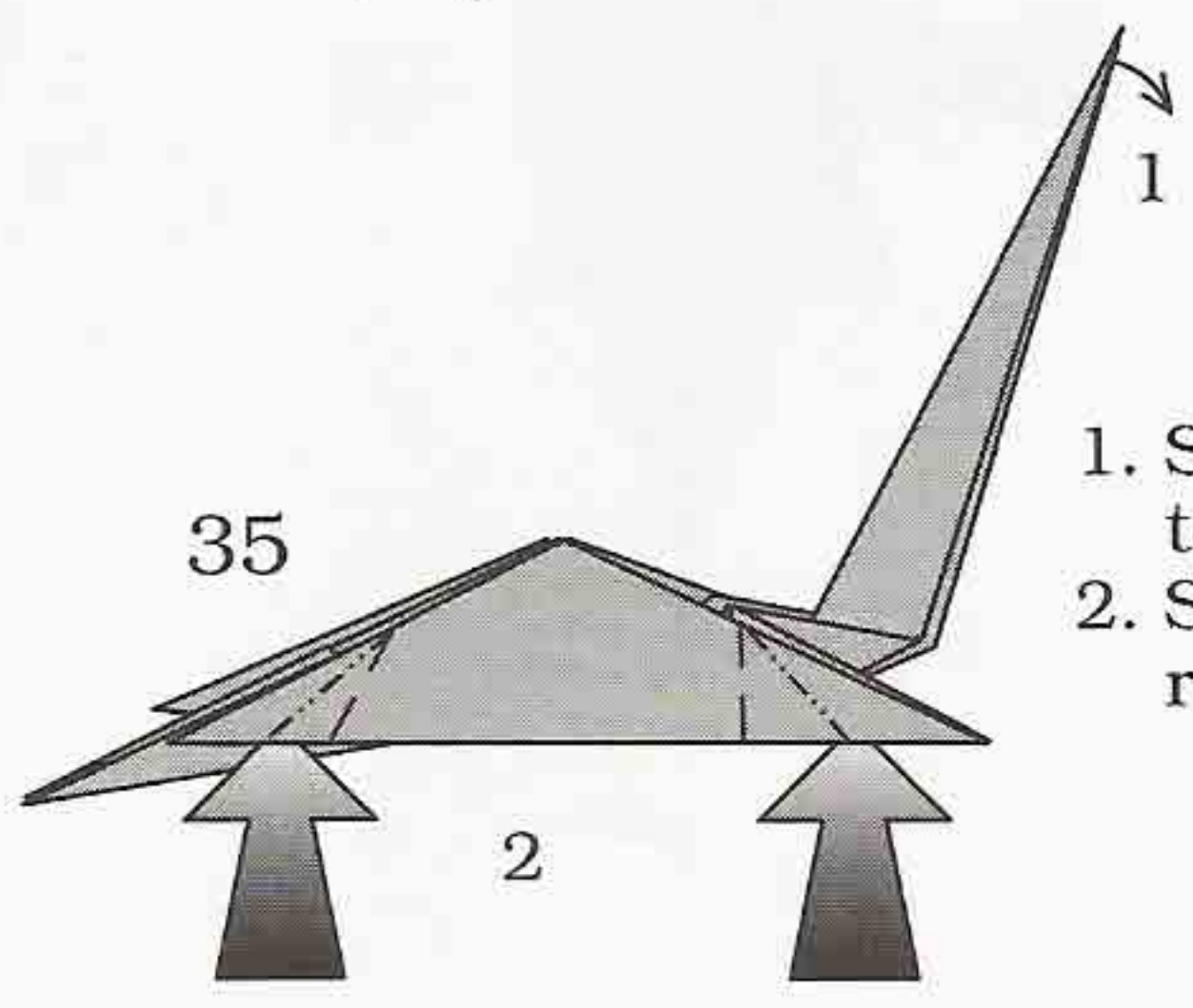
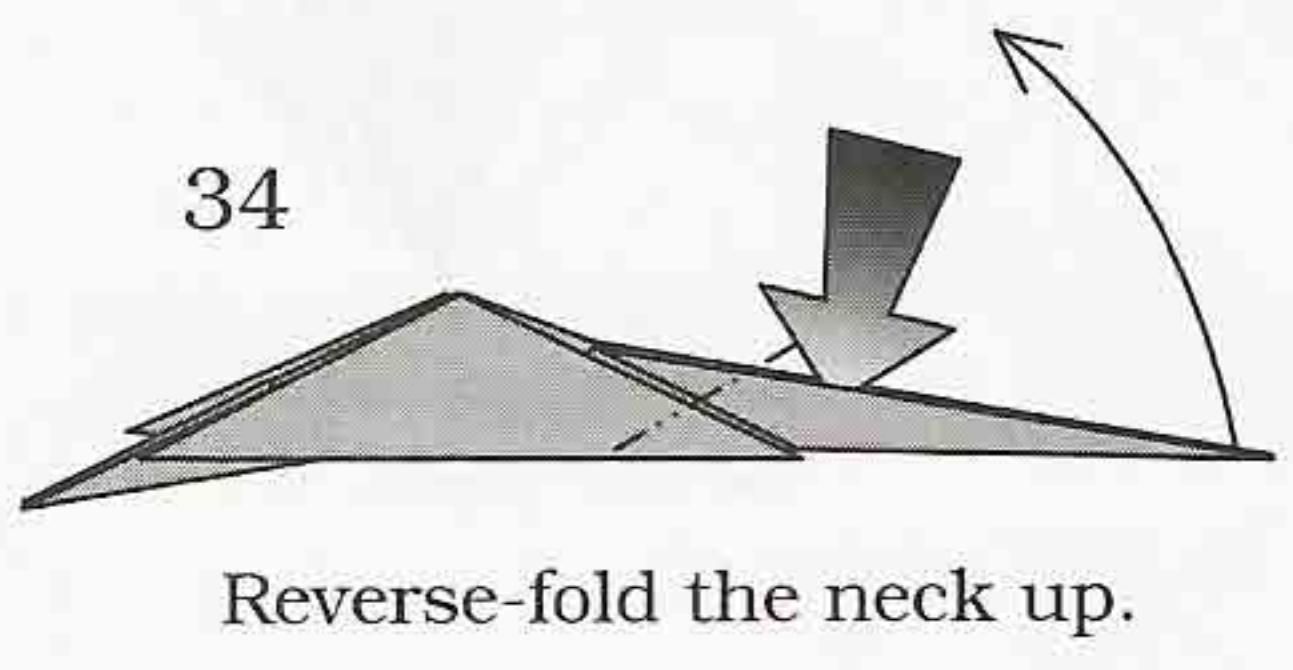
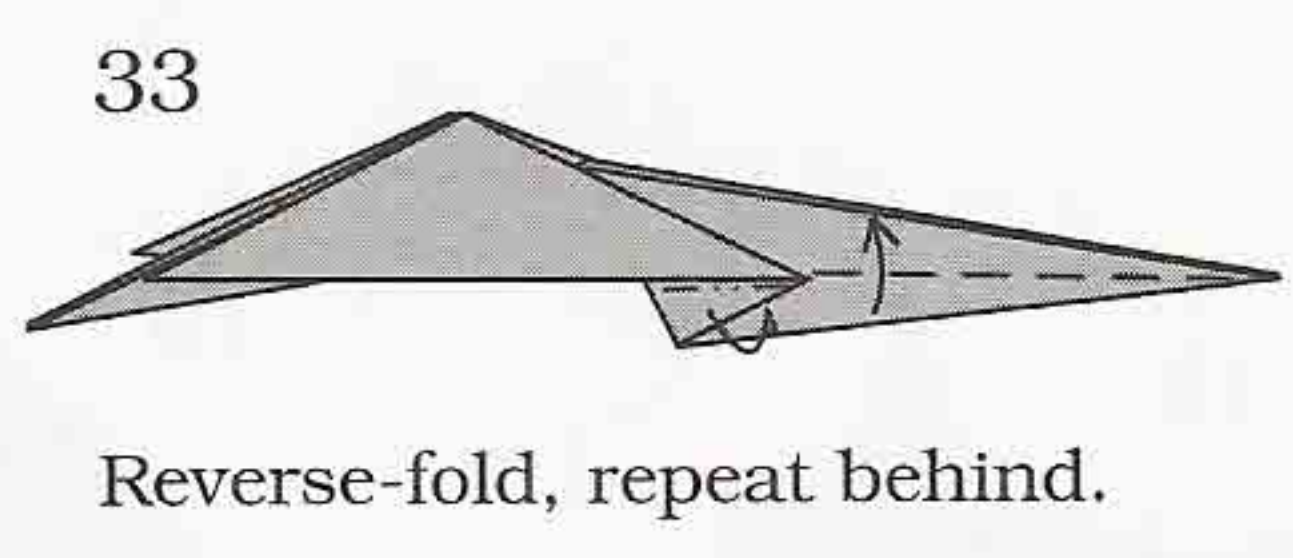
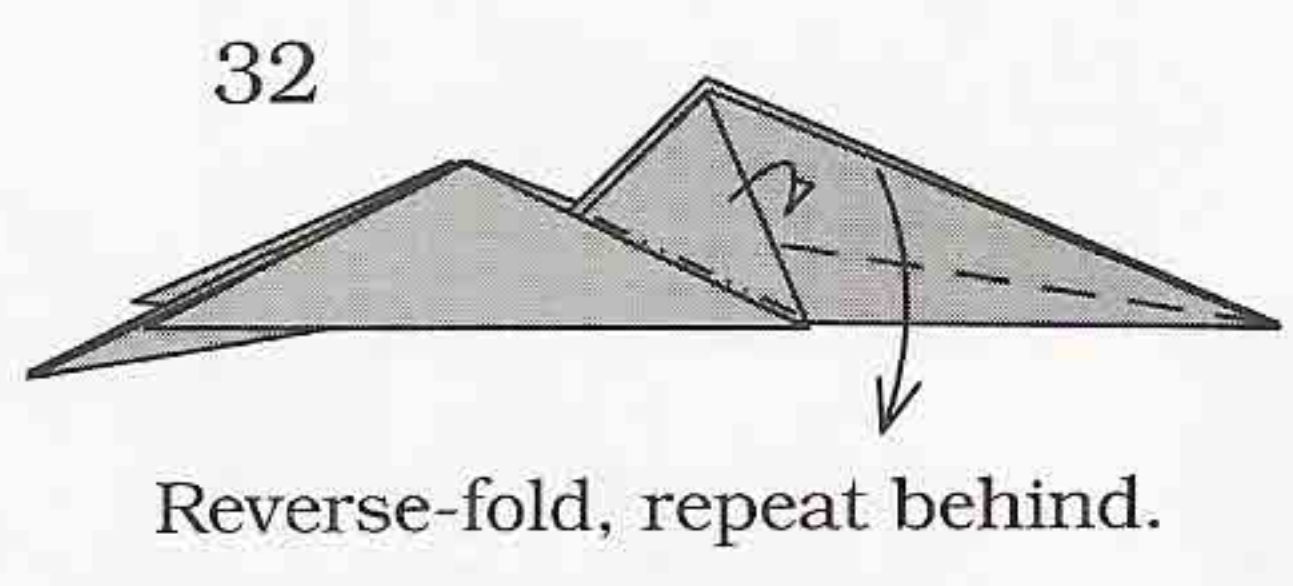
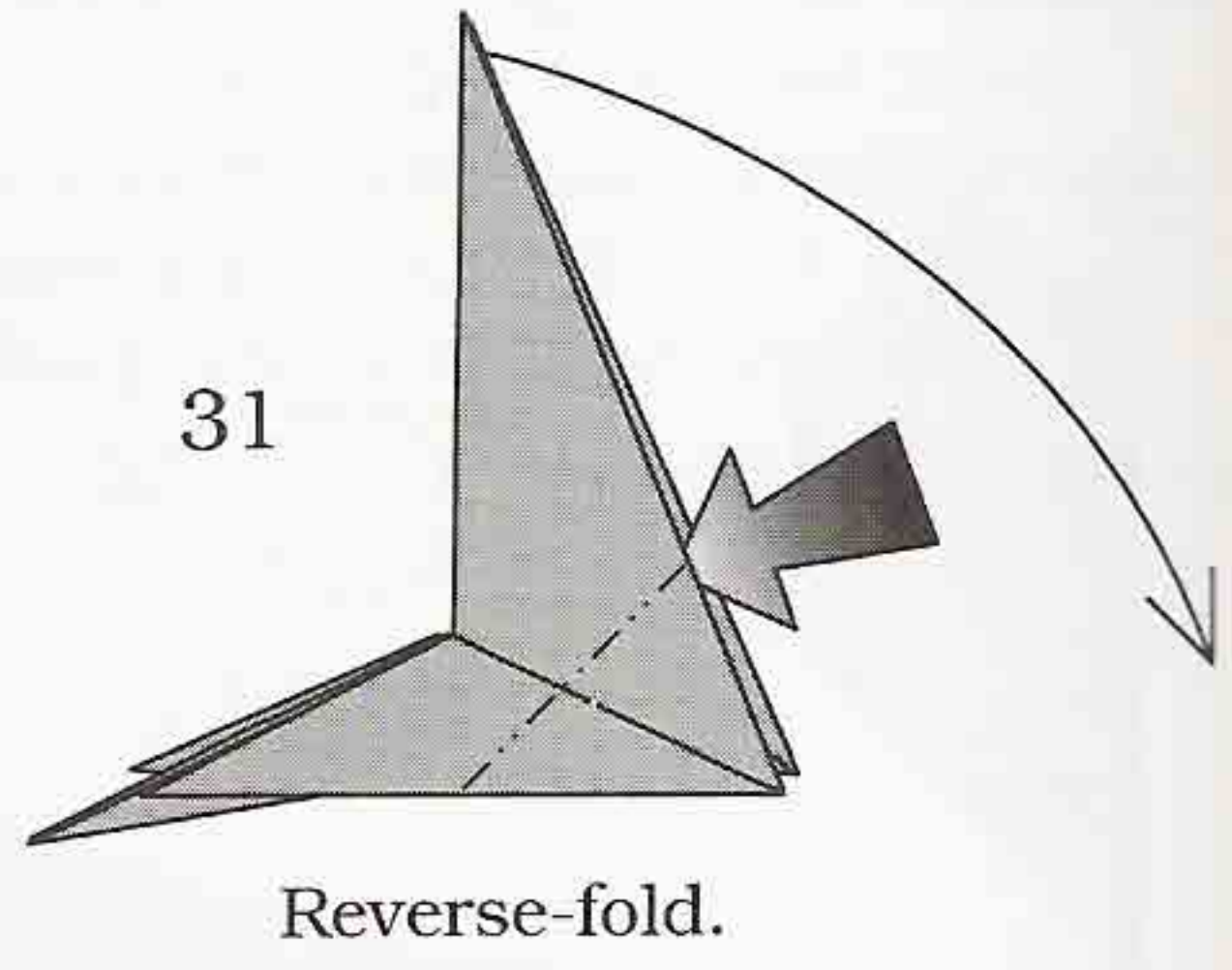
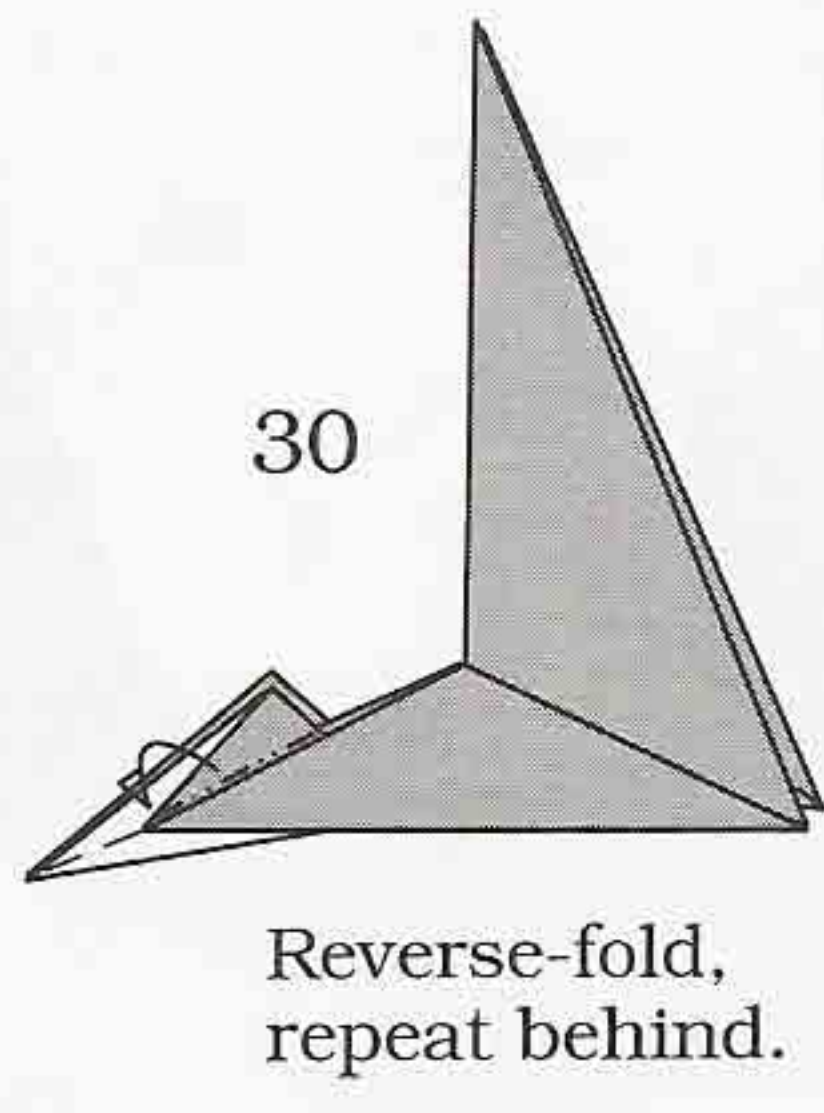
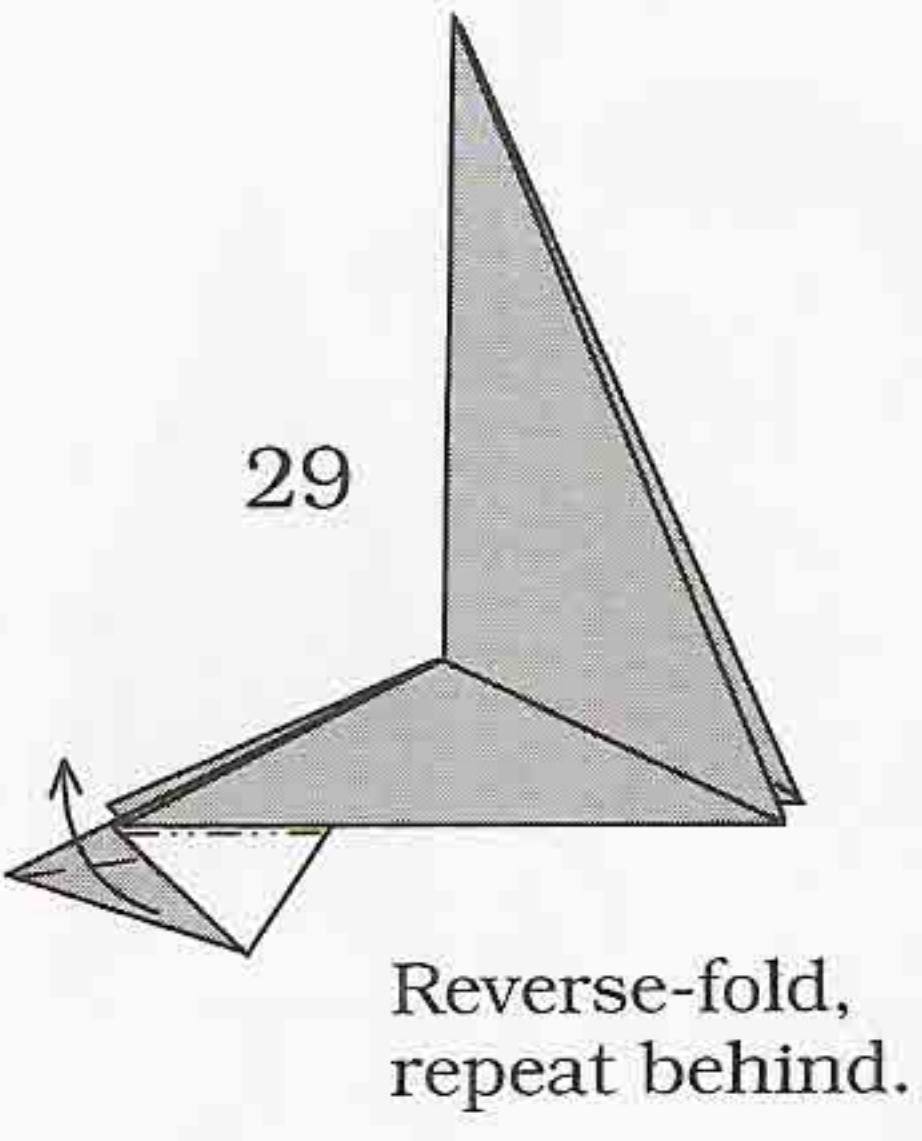
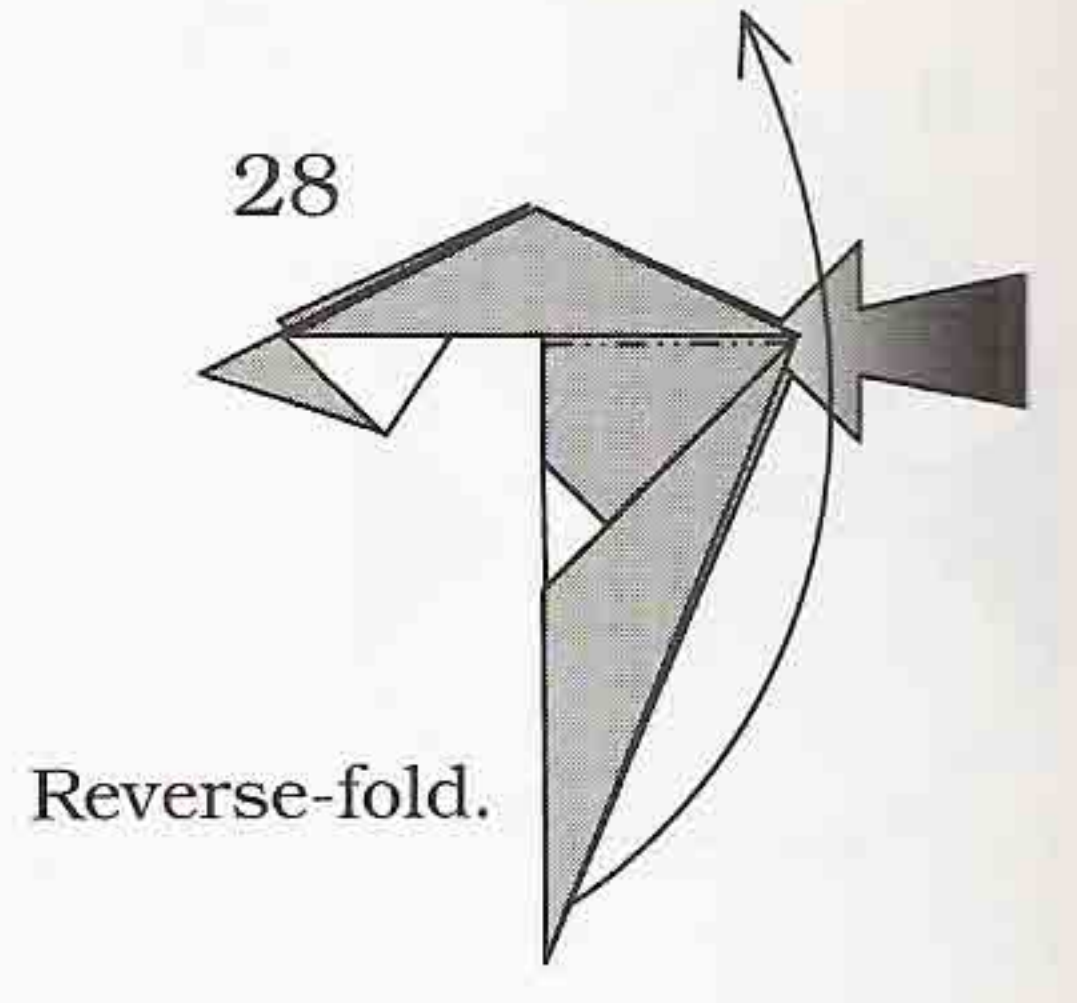
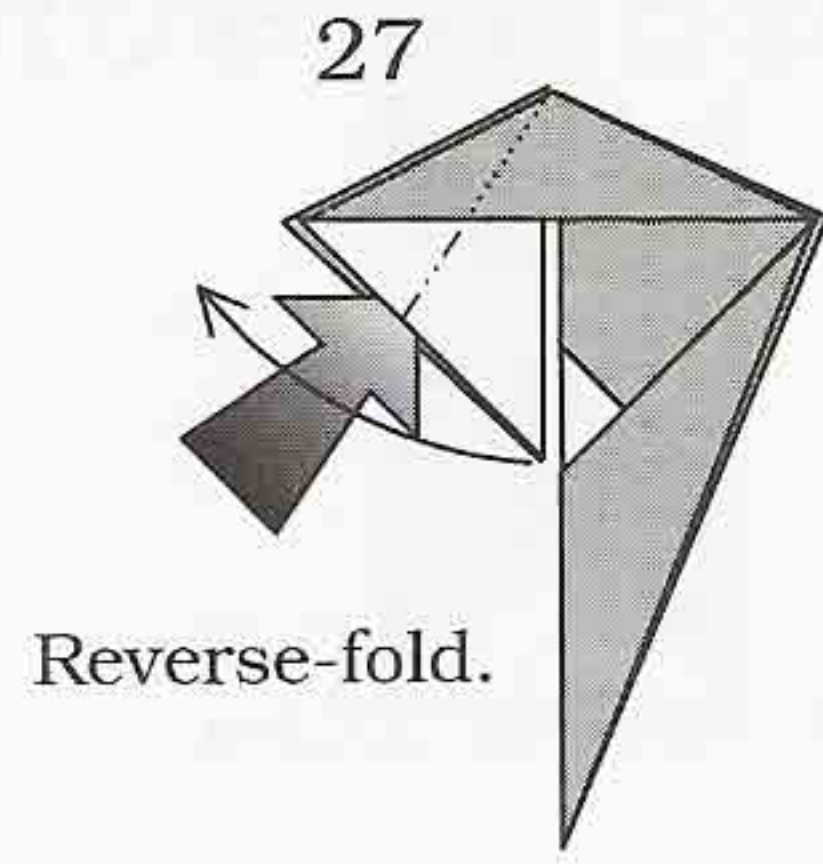
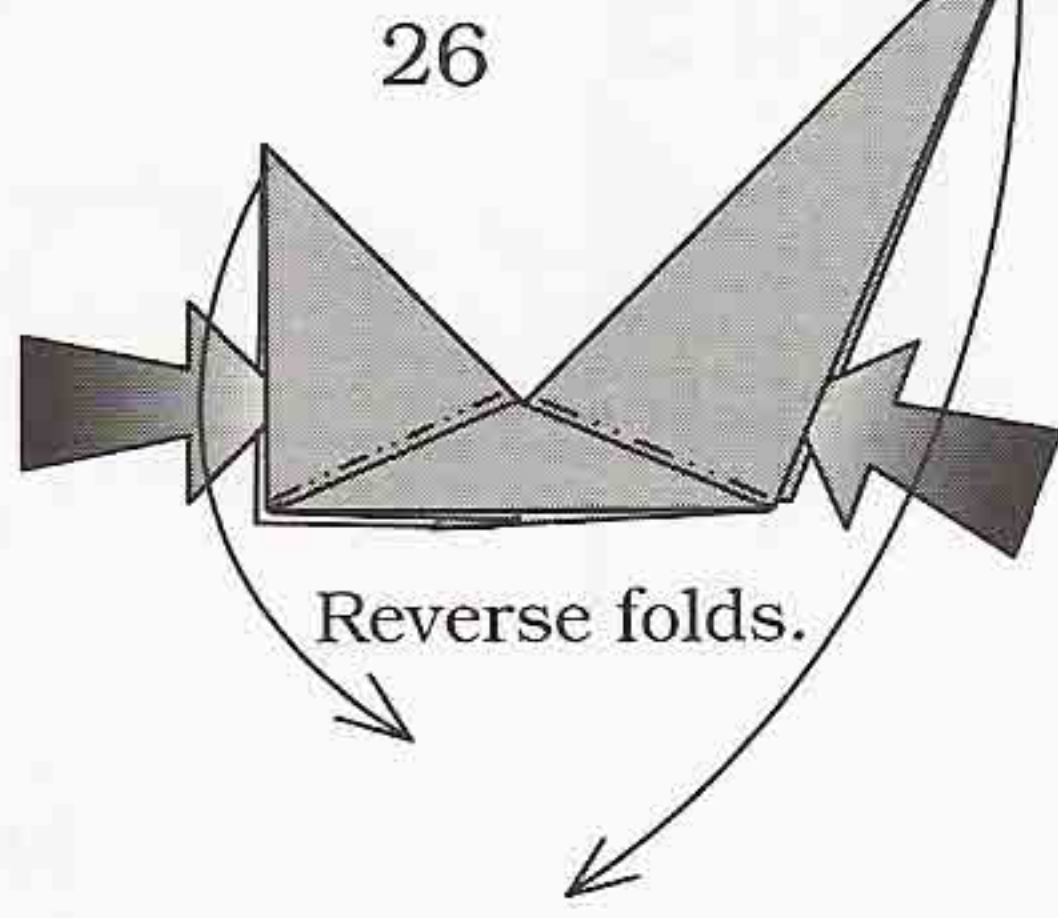
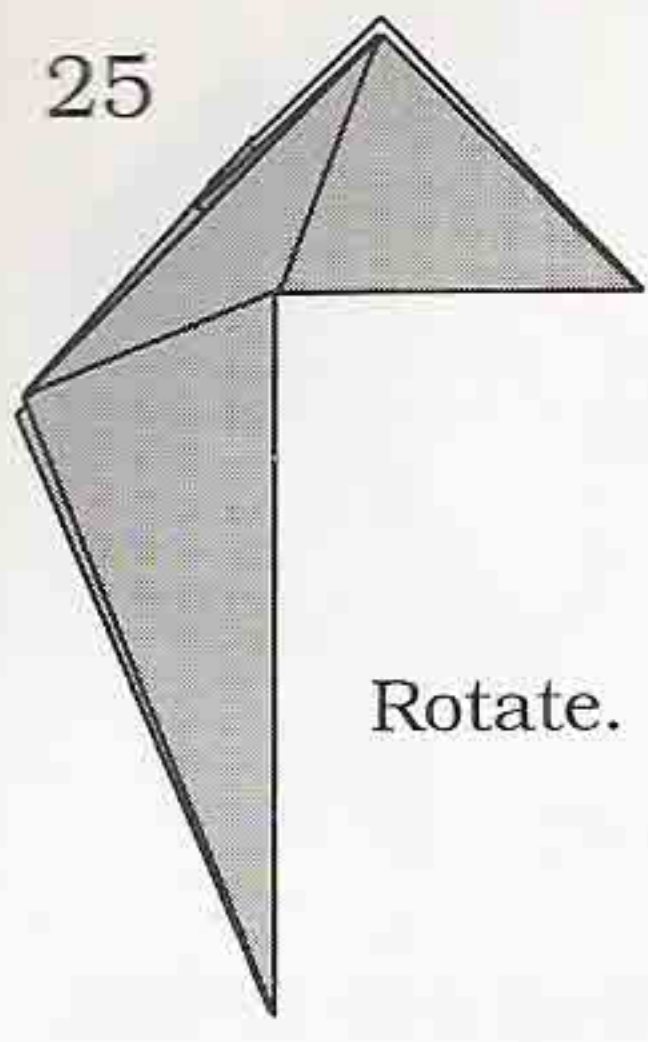

Hadrosaurus

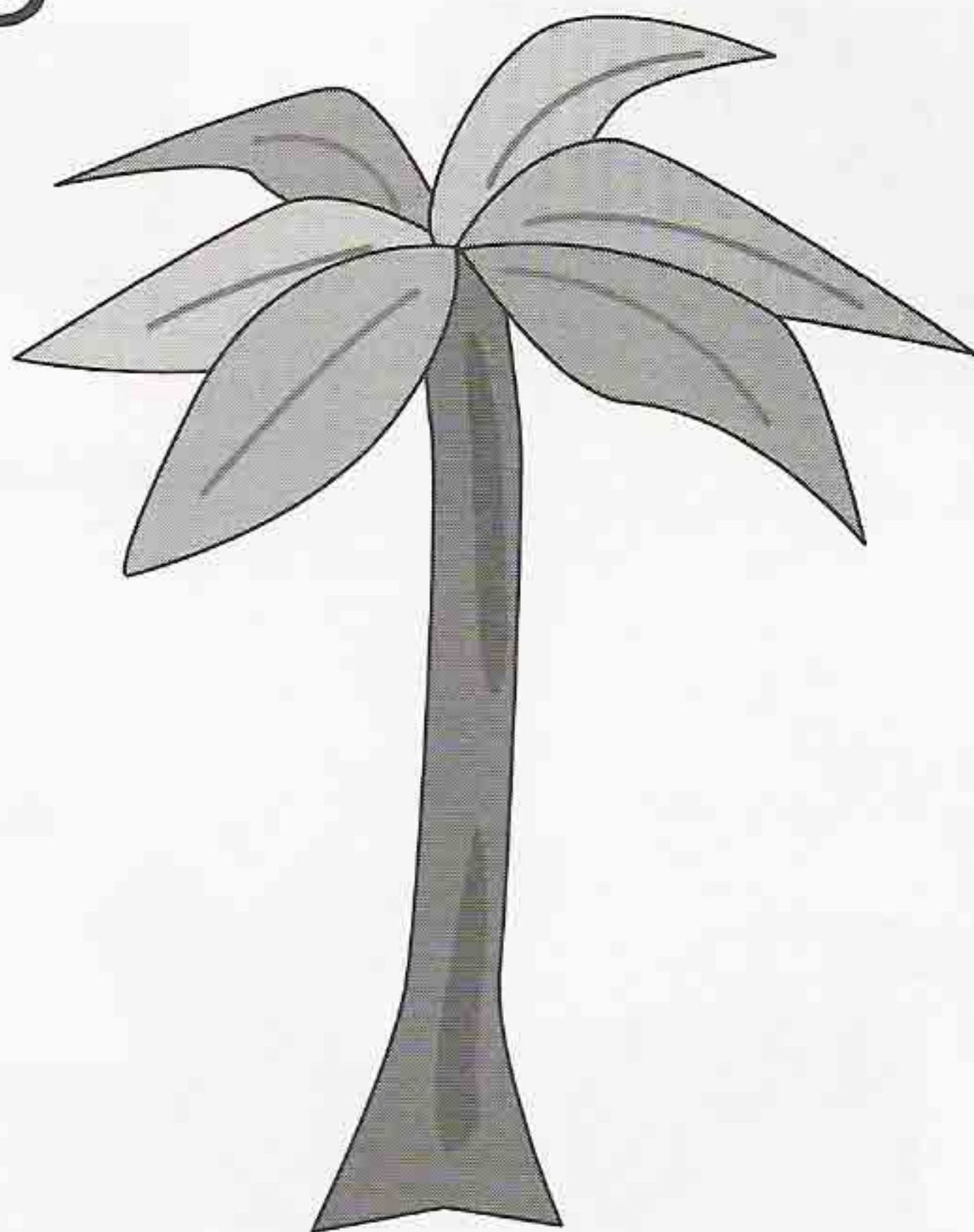
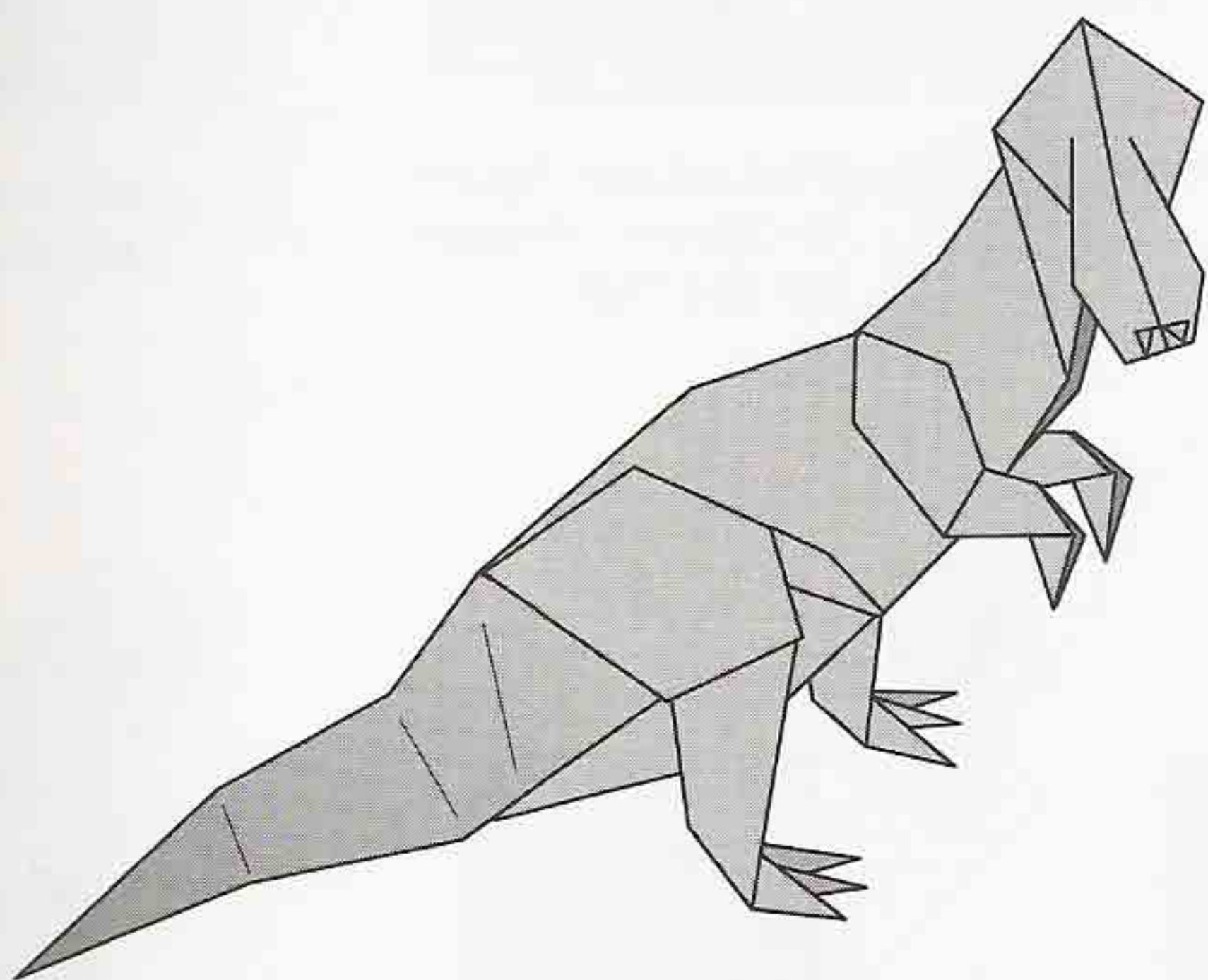

had-ro-SAW-rus

Formerly known as Trachodon, the "rough tooth", this duck billed dinosaur was 33 feet long. Behind the bill were 2000 teeth used for grinding water plants. Hadrosaurus means "bulky lizard" and was the first dinosaur skeleton ever excavated in the U.S. It was found in New Jersey in 1858. Mummified skin has also been found of this Cretaceous creature.

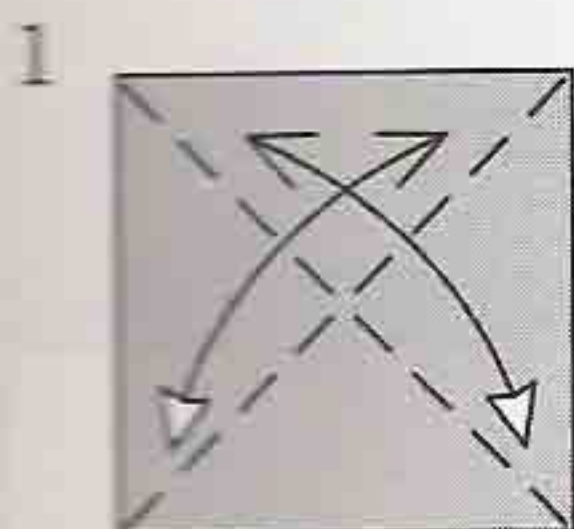

Fold and unfold.

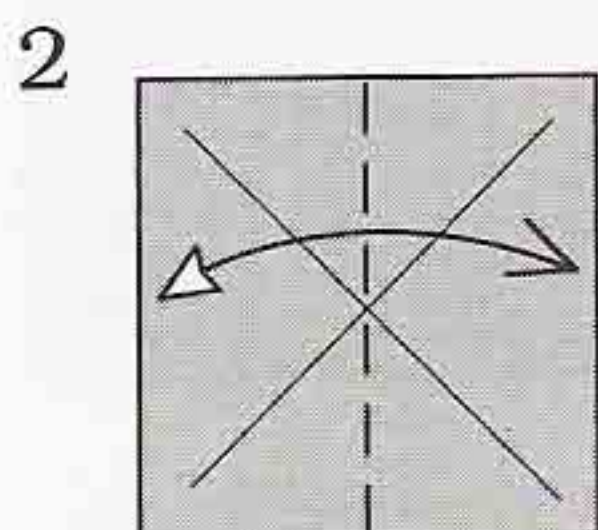

Fold and unfold.

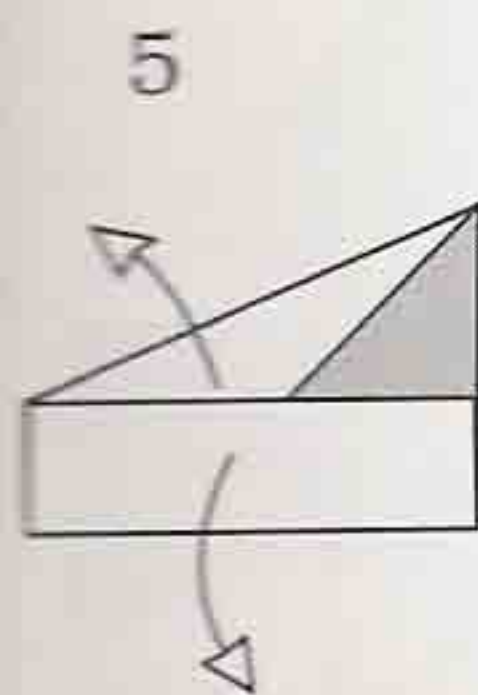
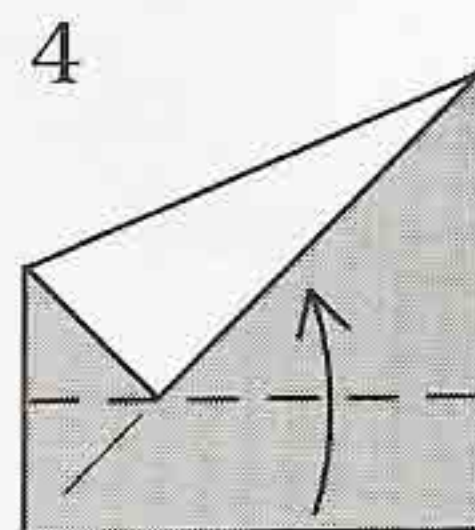
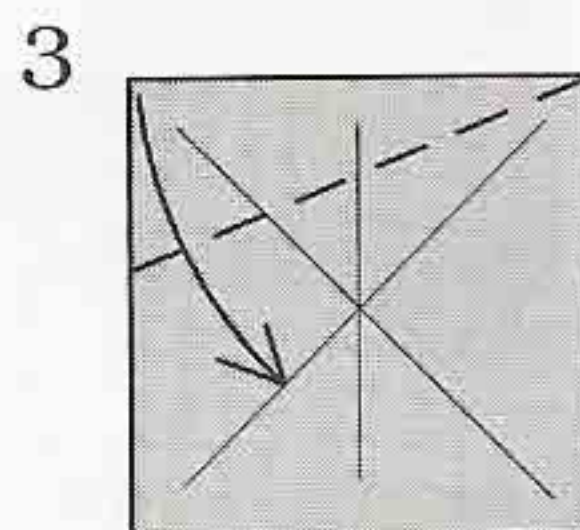

Unfold.

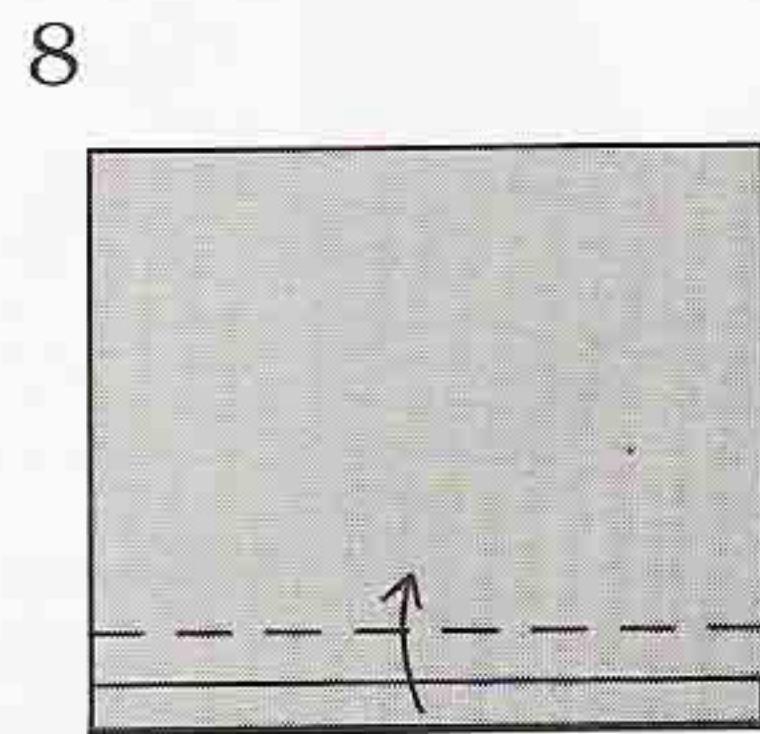
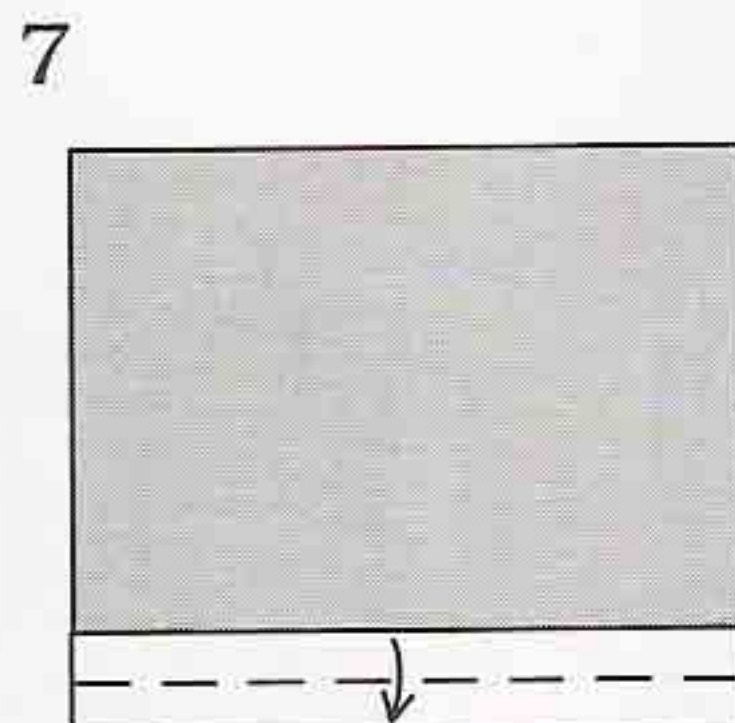
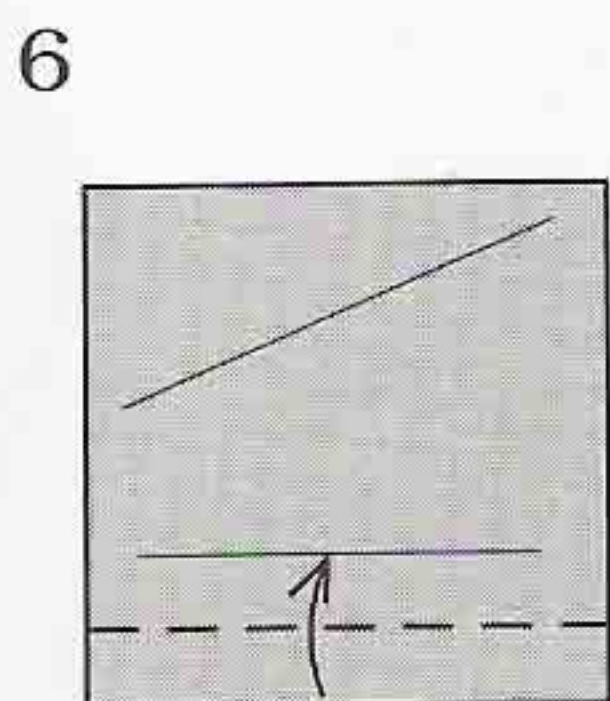

Fold along the existing crease.

9

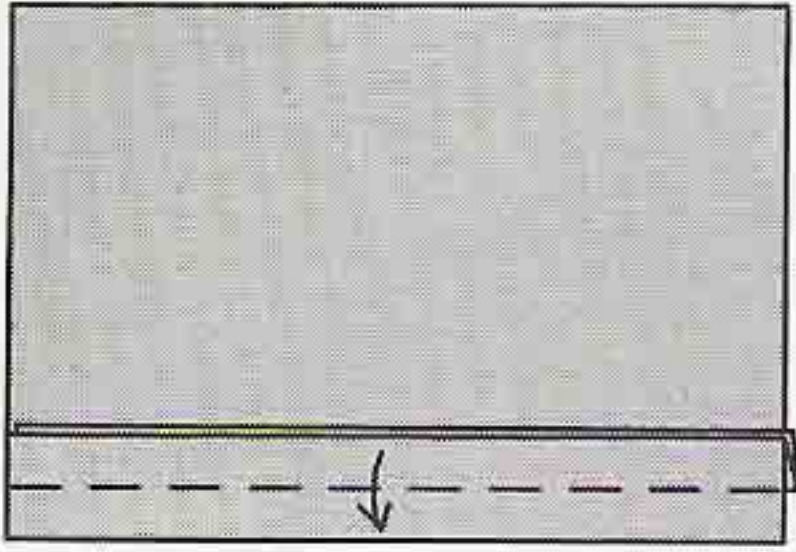

10

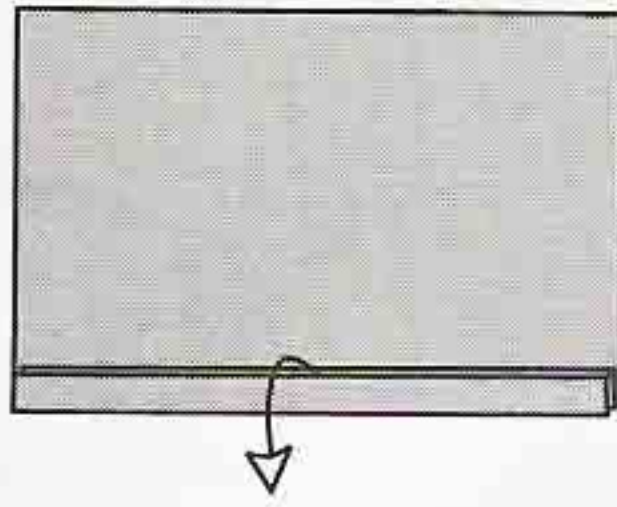

Unfold one layer.

11

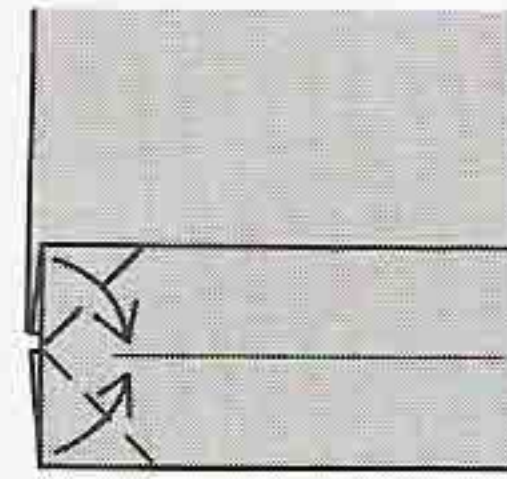

Part of the figure is drawn. Repeat on the right.

12

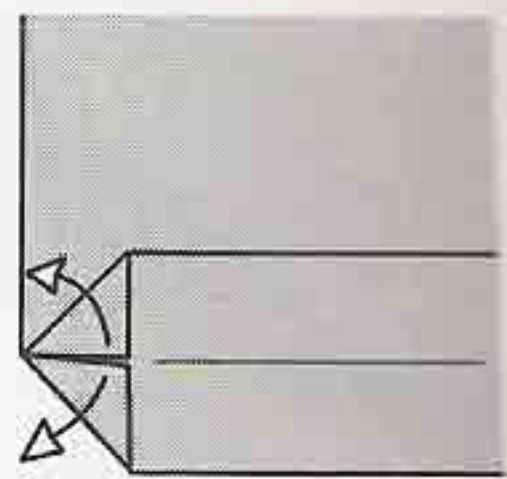

Unfold, repeat on the right.

13

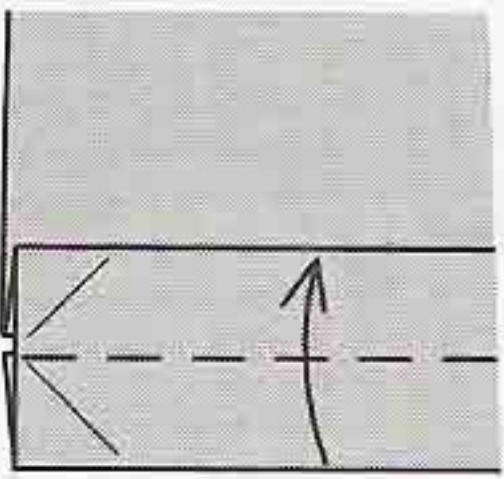

14

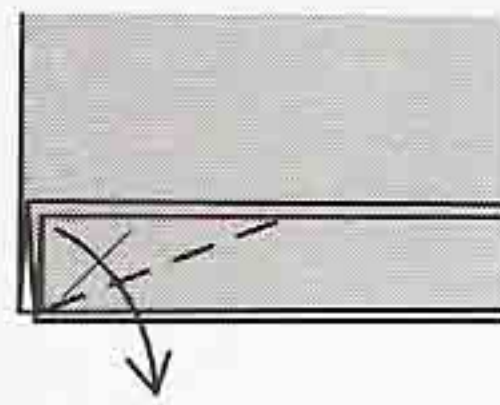

Repeat on the right.

15

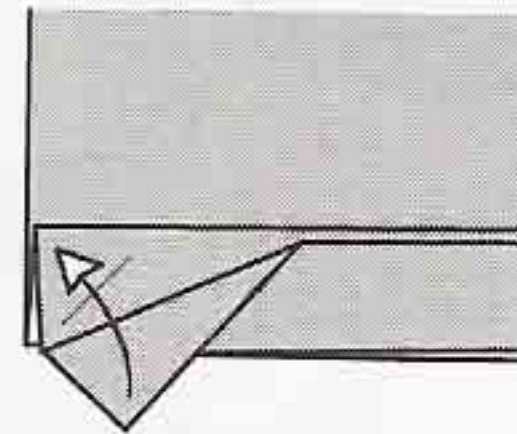

Unfold, repeat on the right.

16

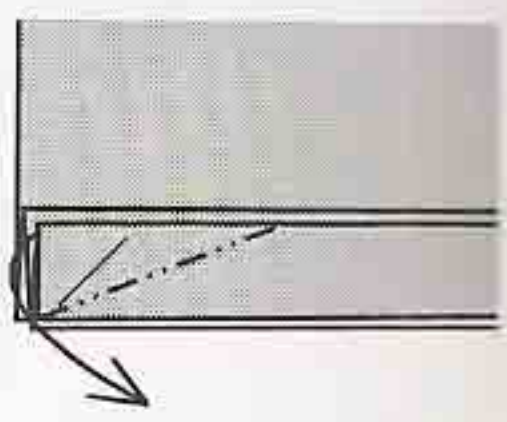

Reverse-fold, repeat on the right.

17

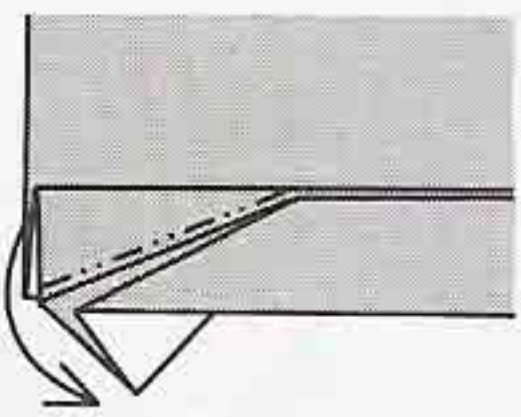

Reverse-fold, repeat on the right.

18

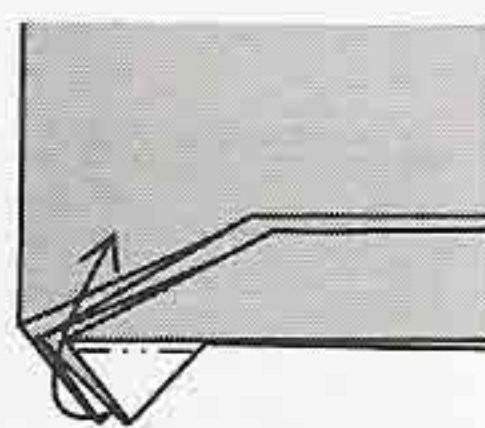

Two reverse folds, repeat on the right.

19

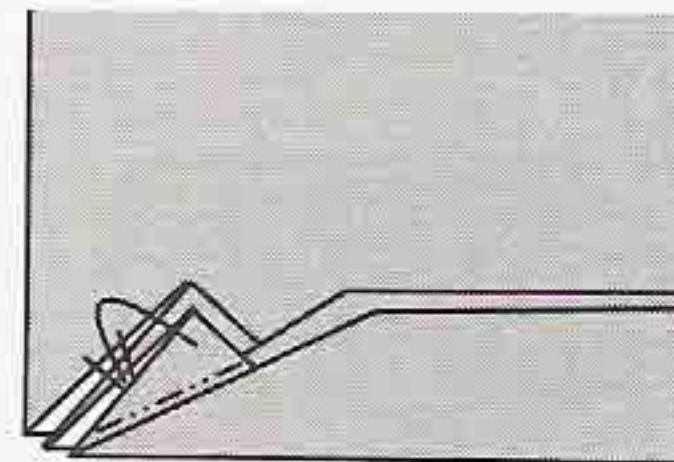

Two reverse folds, repeat on the right.

20

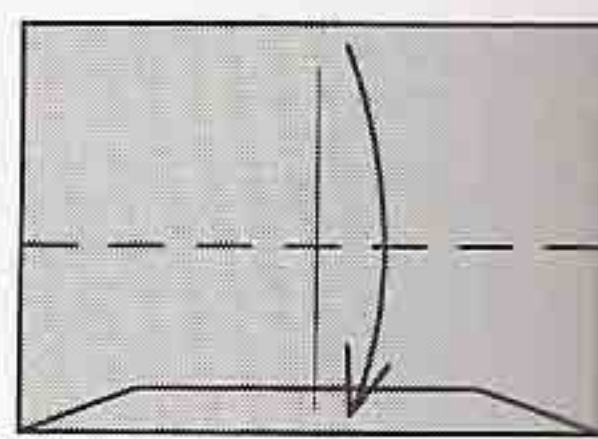

22

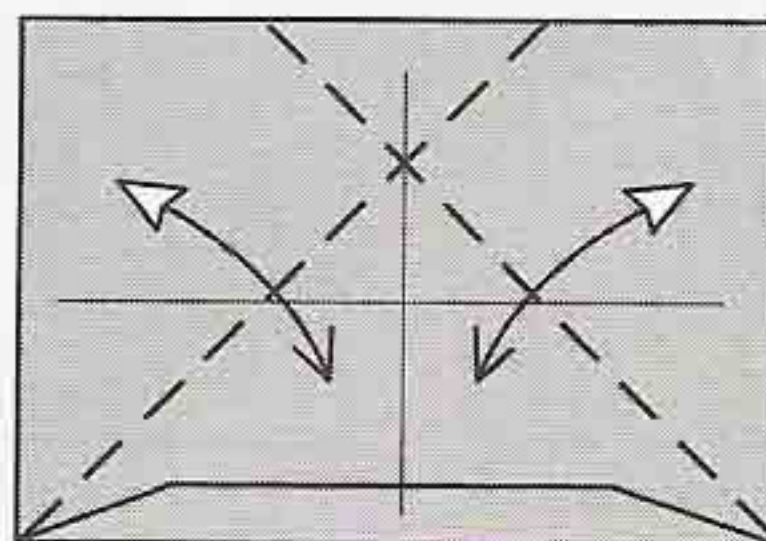

Fold and unfold.

23

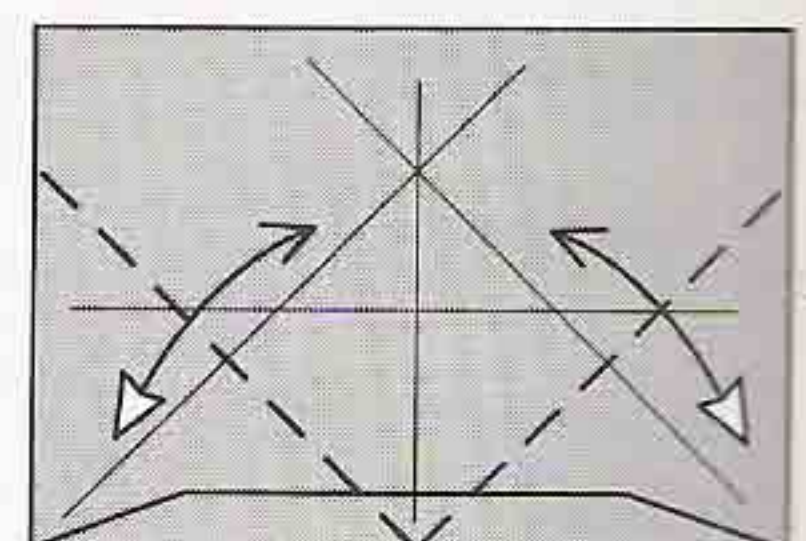

Fold and unfold.

21

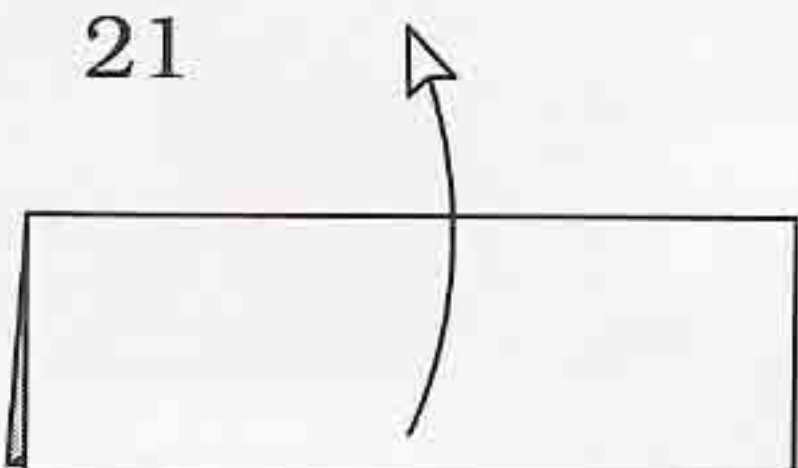

Unfold.

24

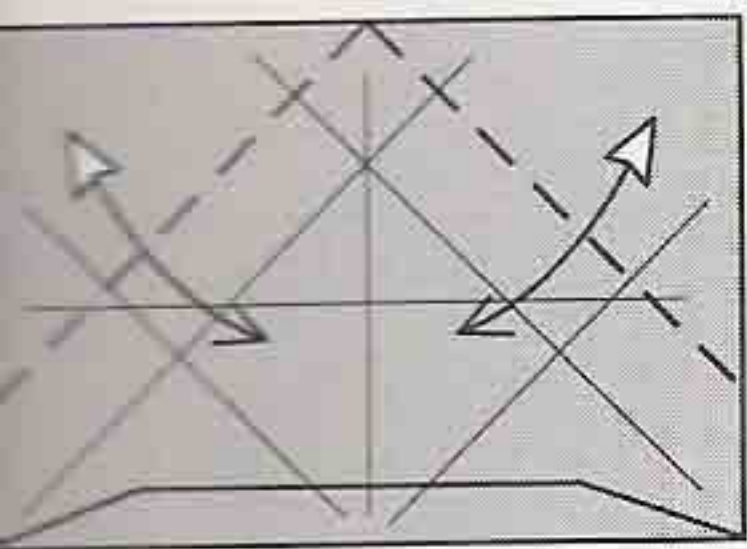

Fold and unfold.

25

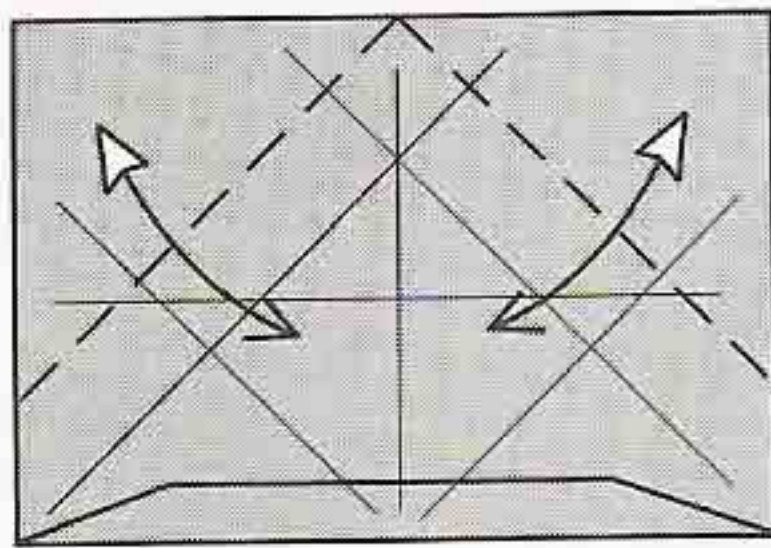

Fold and unfold.

26

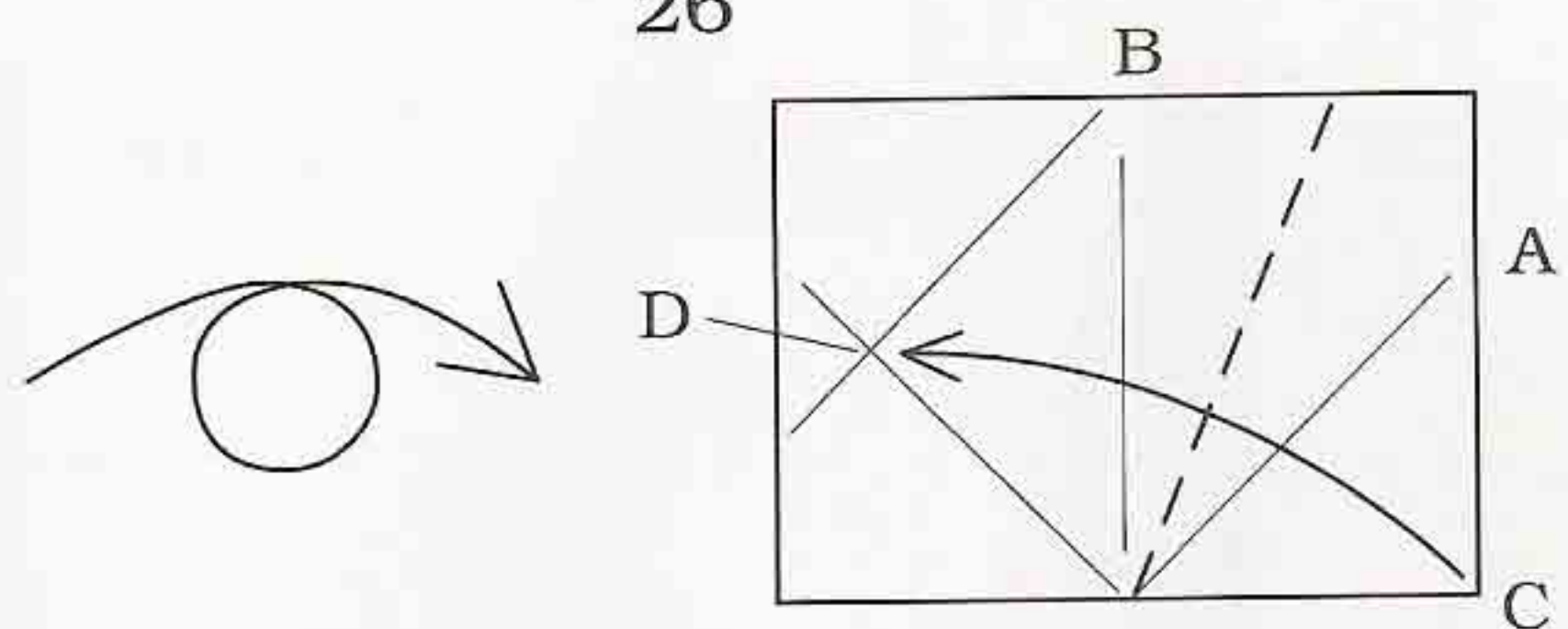

Fold A to B and C to D.

27

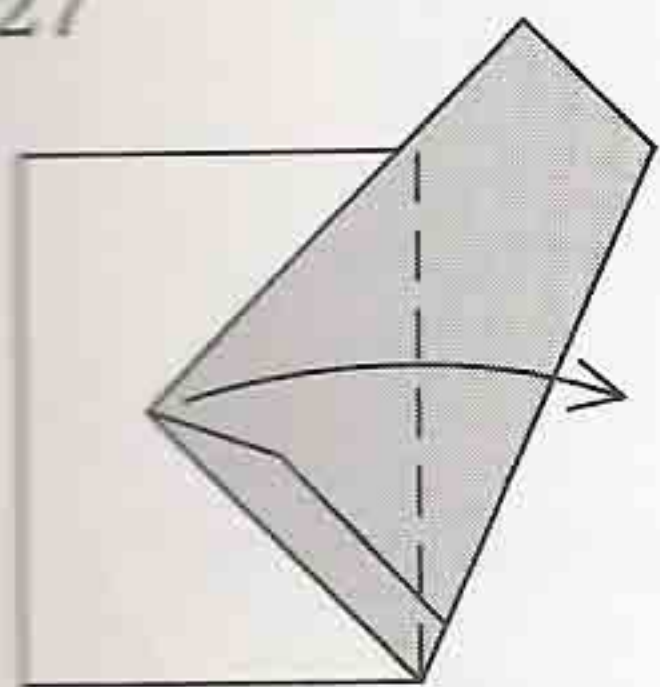

28

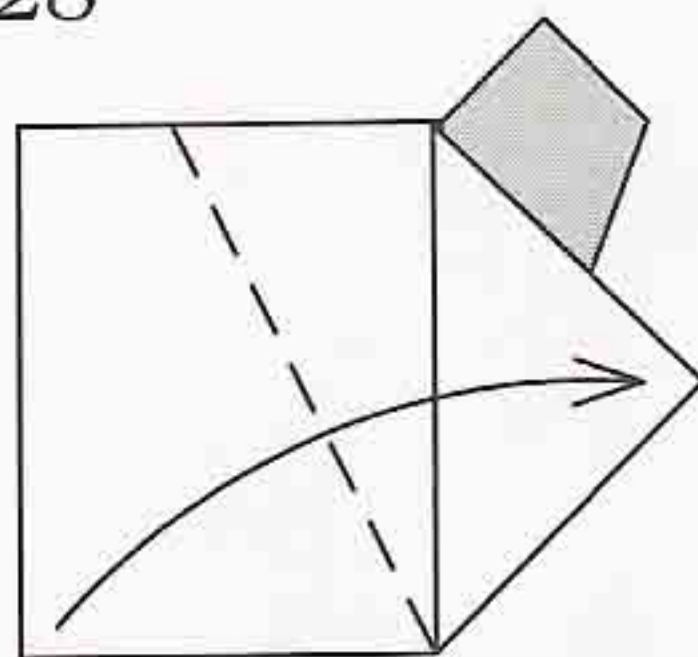

29

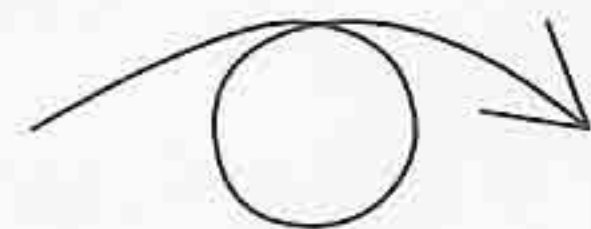
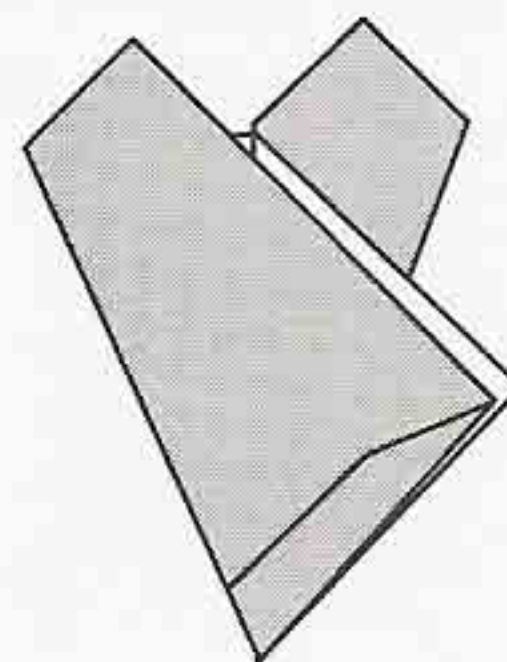

30

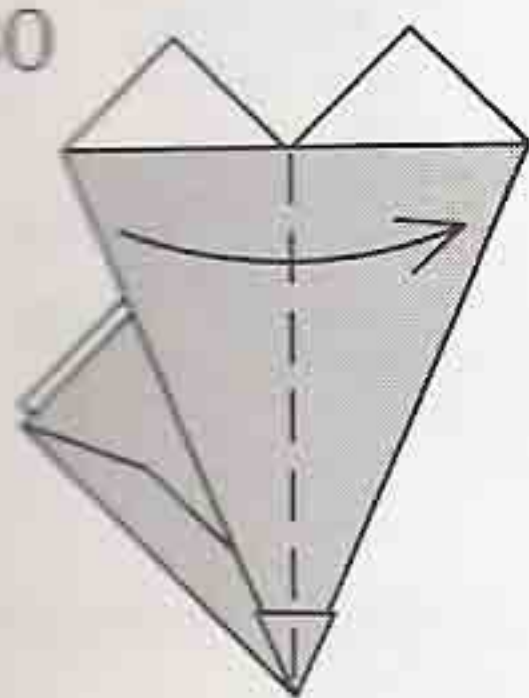

31

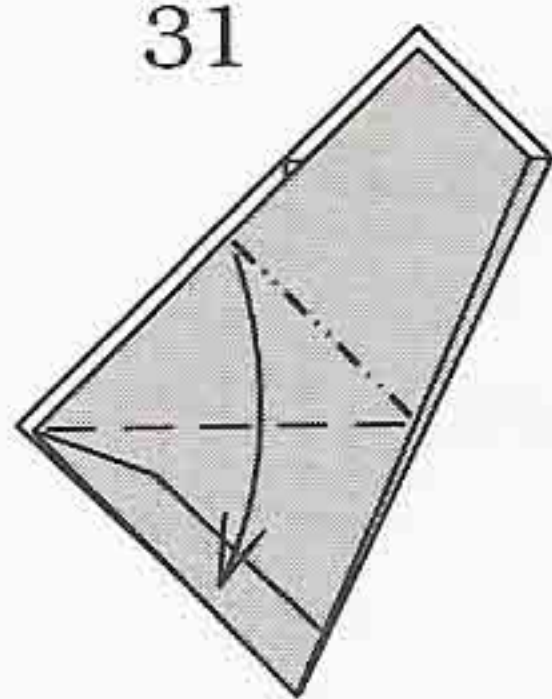

Squash-fold.

32

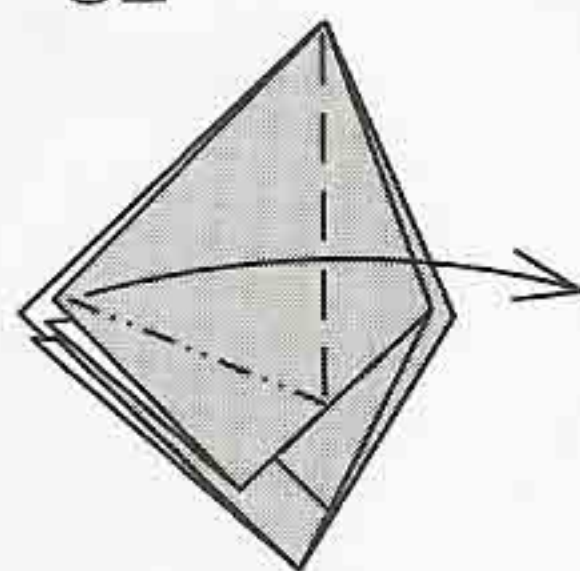

Repeat behind.

33

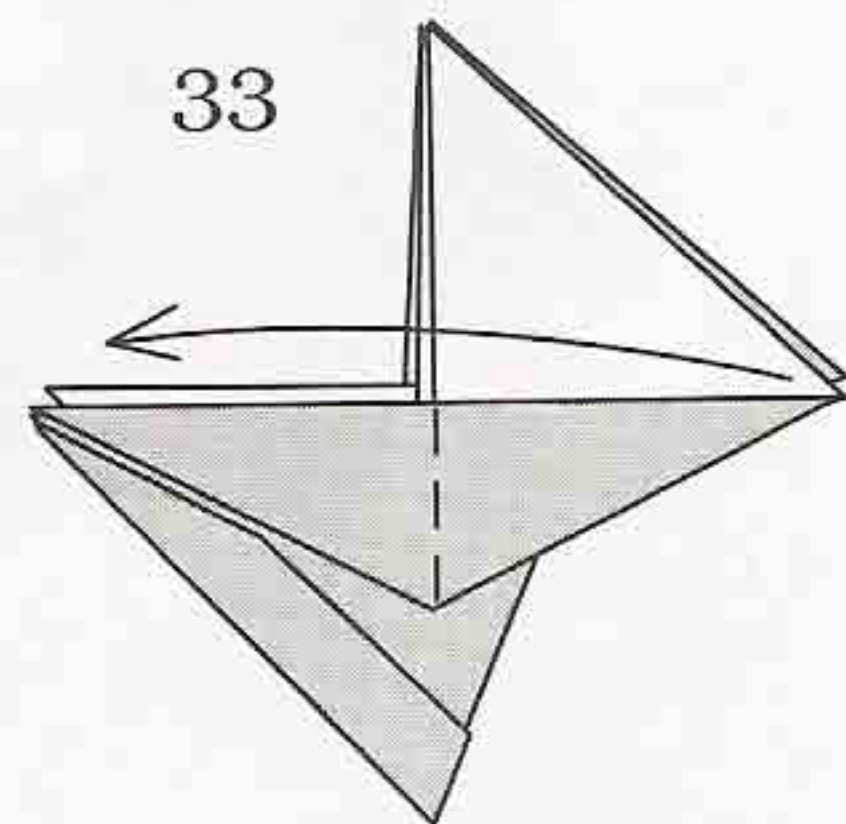

Repeat behind.

34

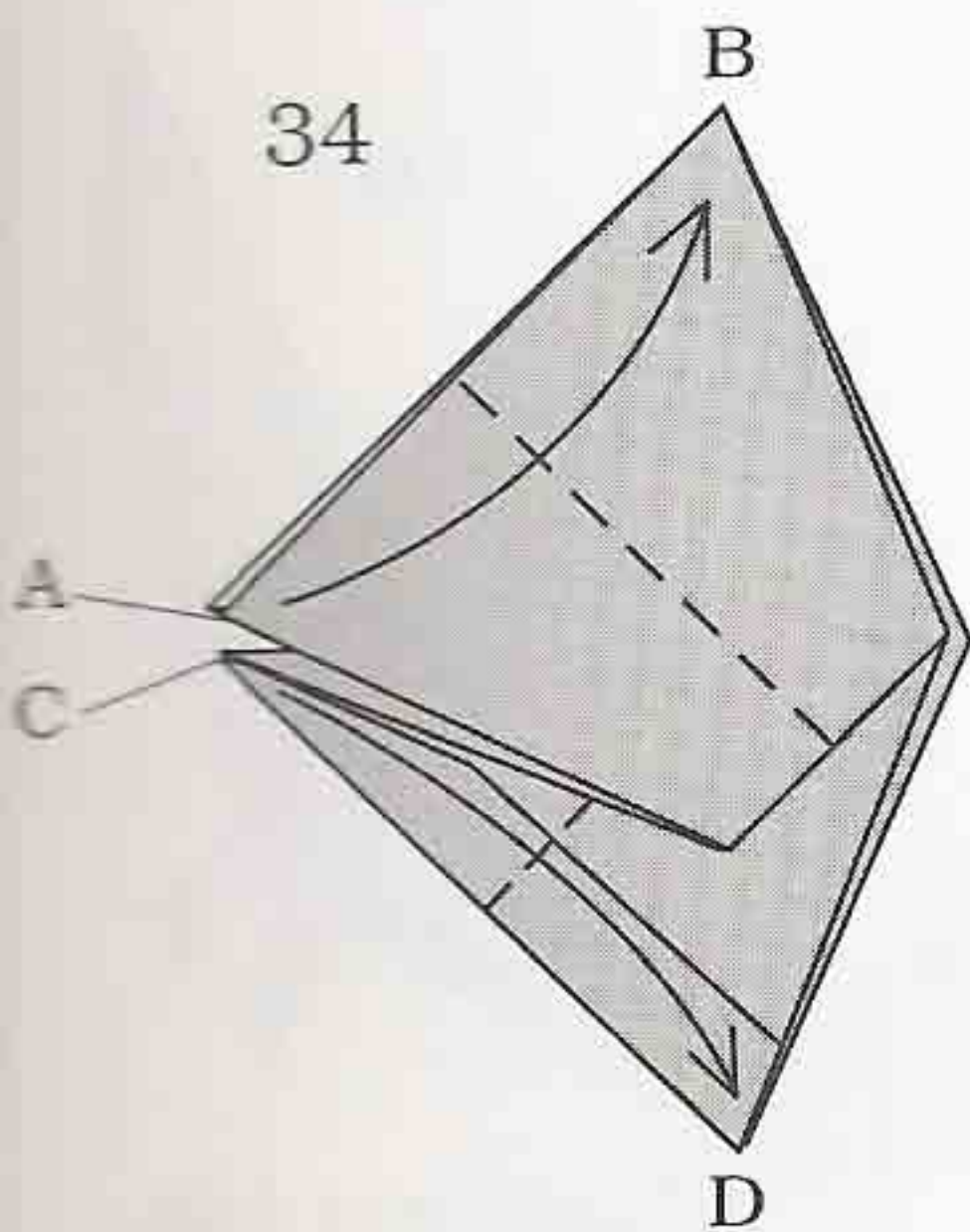

Fold A to B and C to D, repeat behind.

35

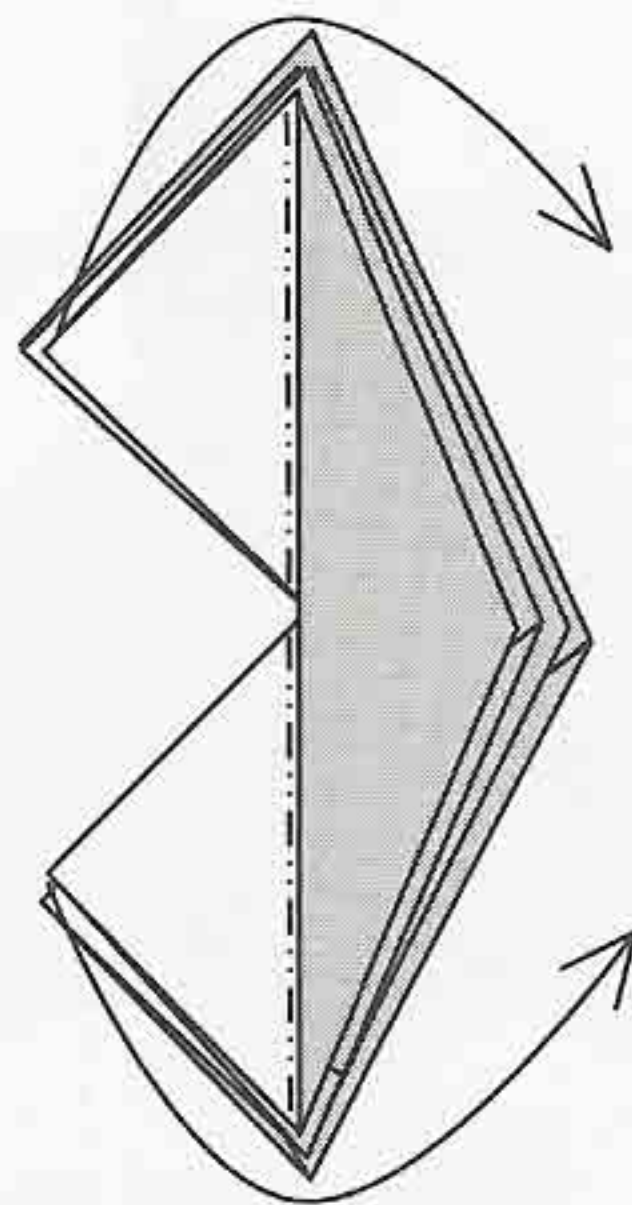

Reverse folds, repeat behind.

36

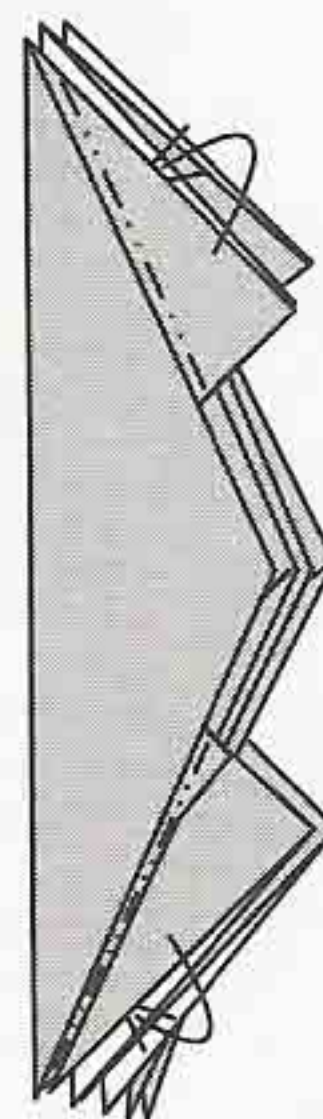

Four reverse folds.

37

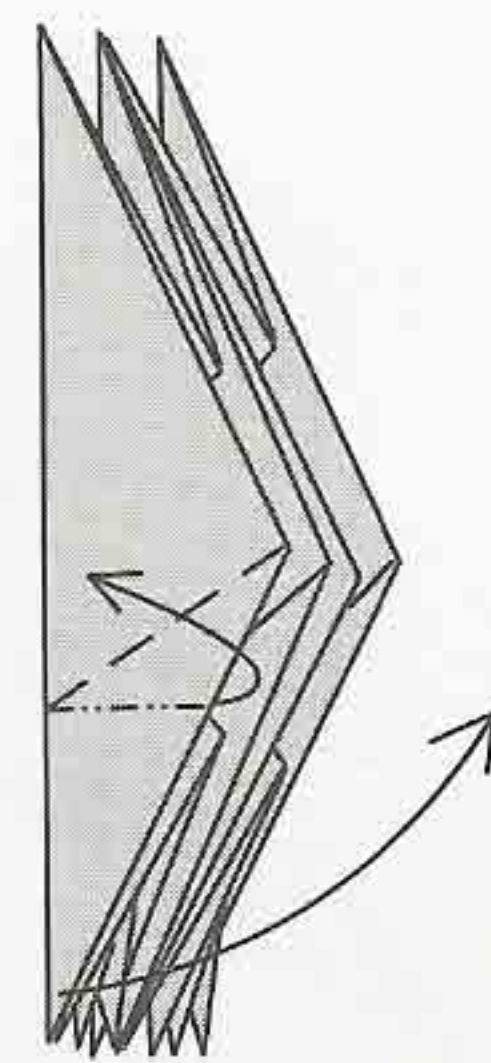

Repeat behind.

38

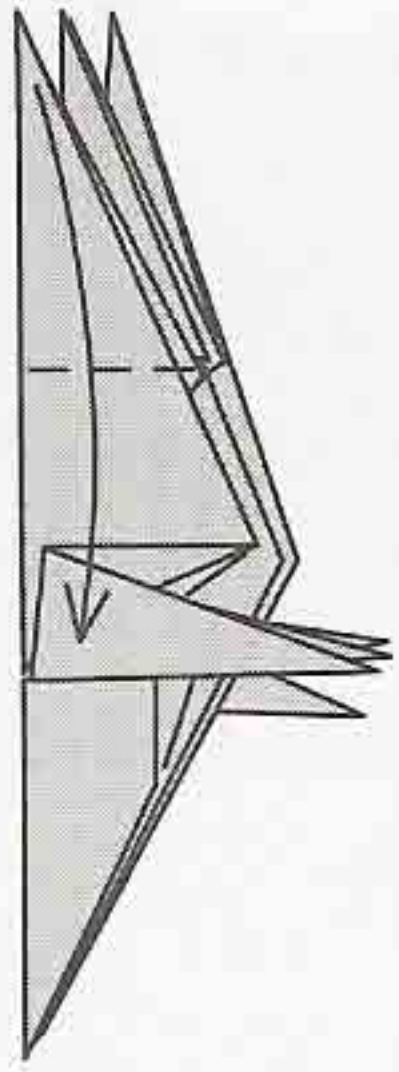

Repeat behind.

39

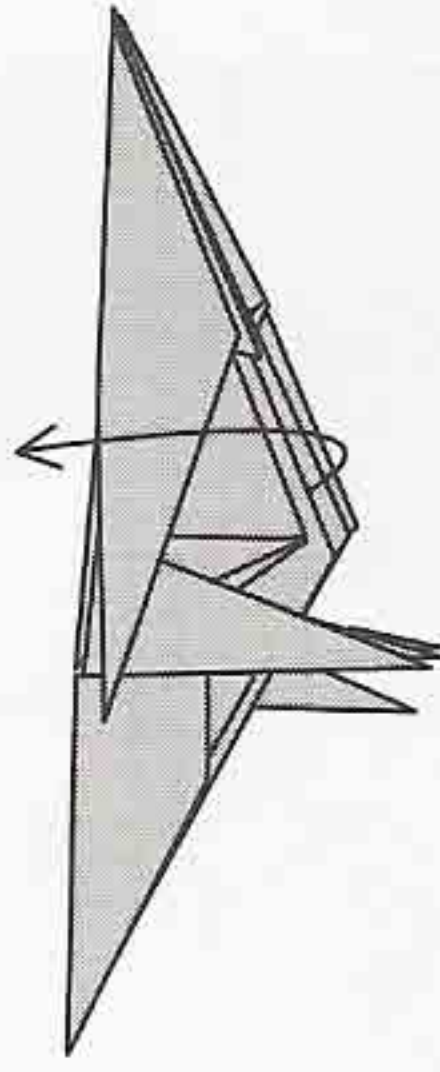

40

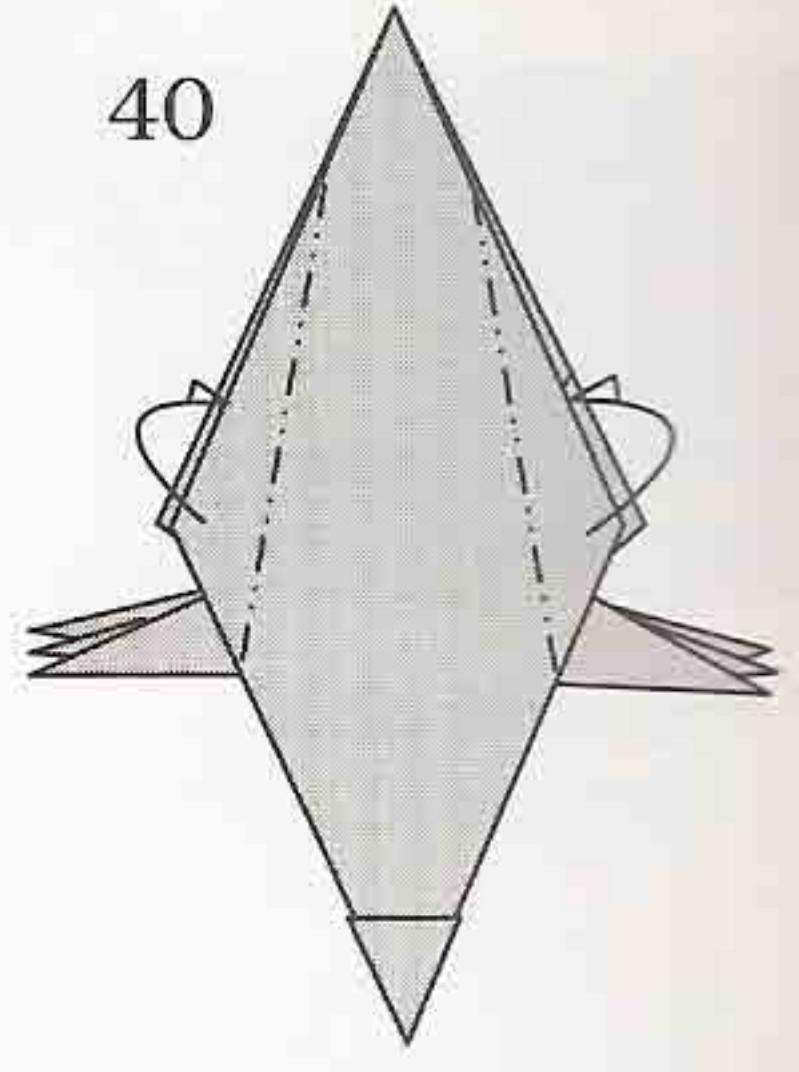

Tuck behind.

41

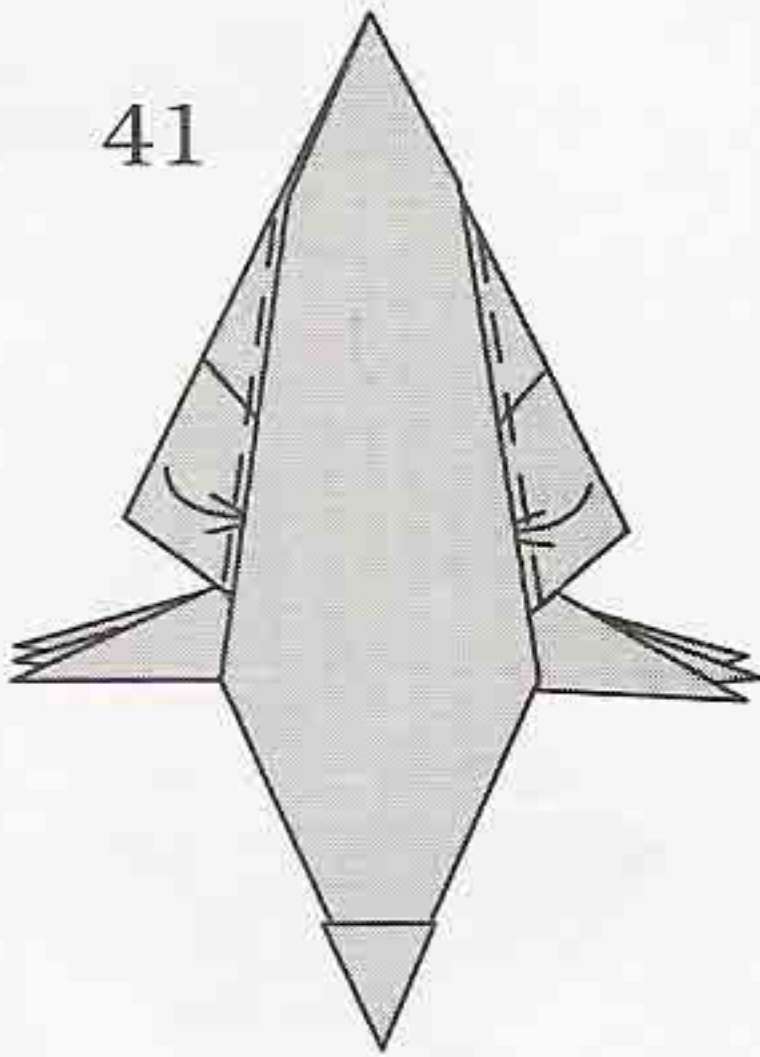

42

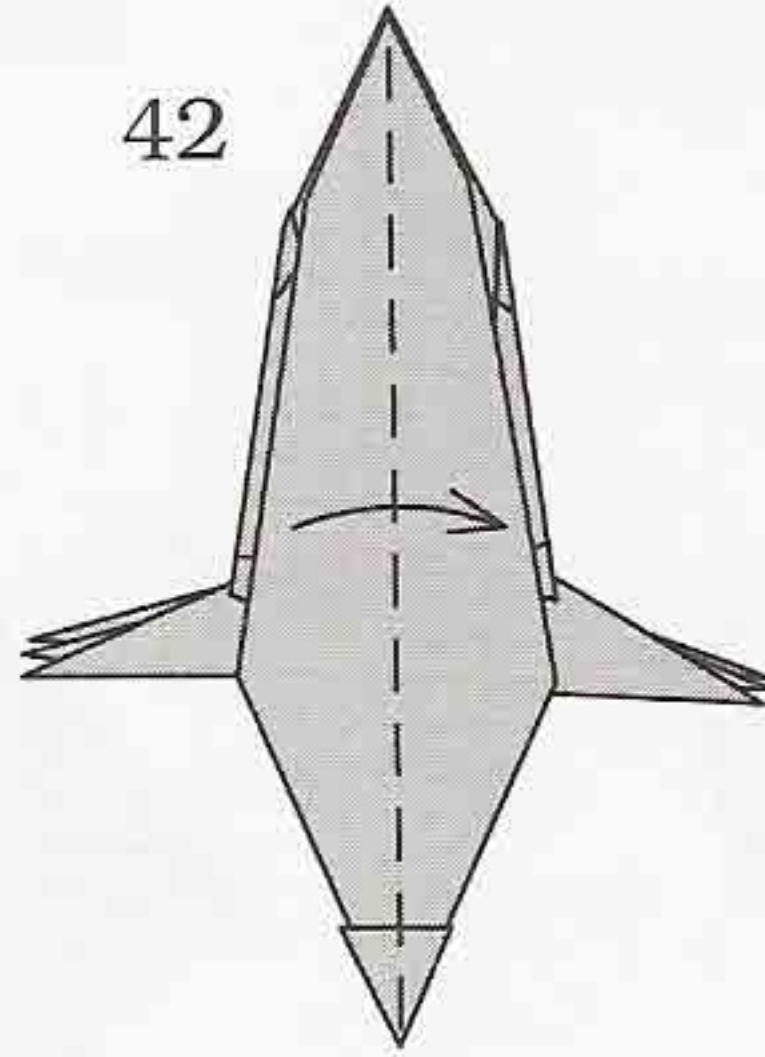

43

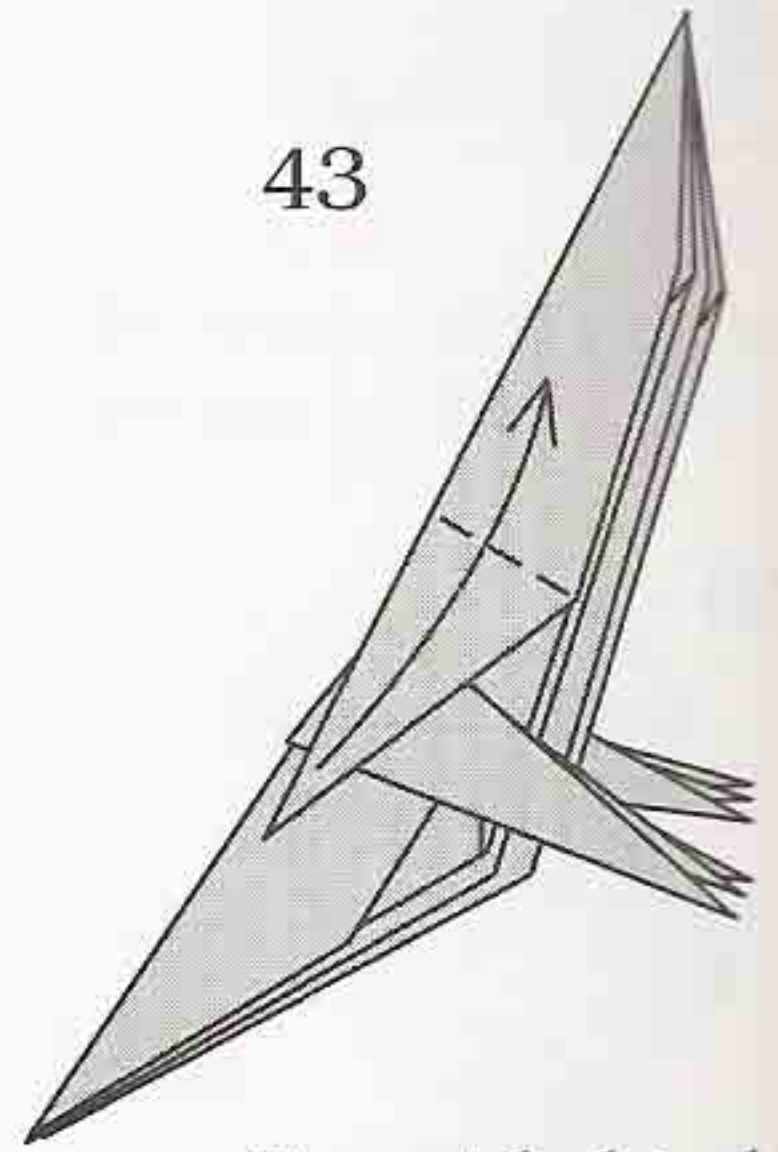

Repeat behind.

44

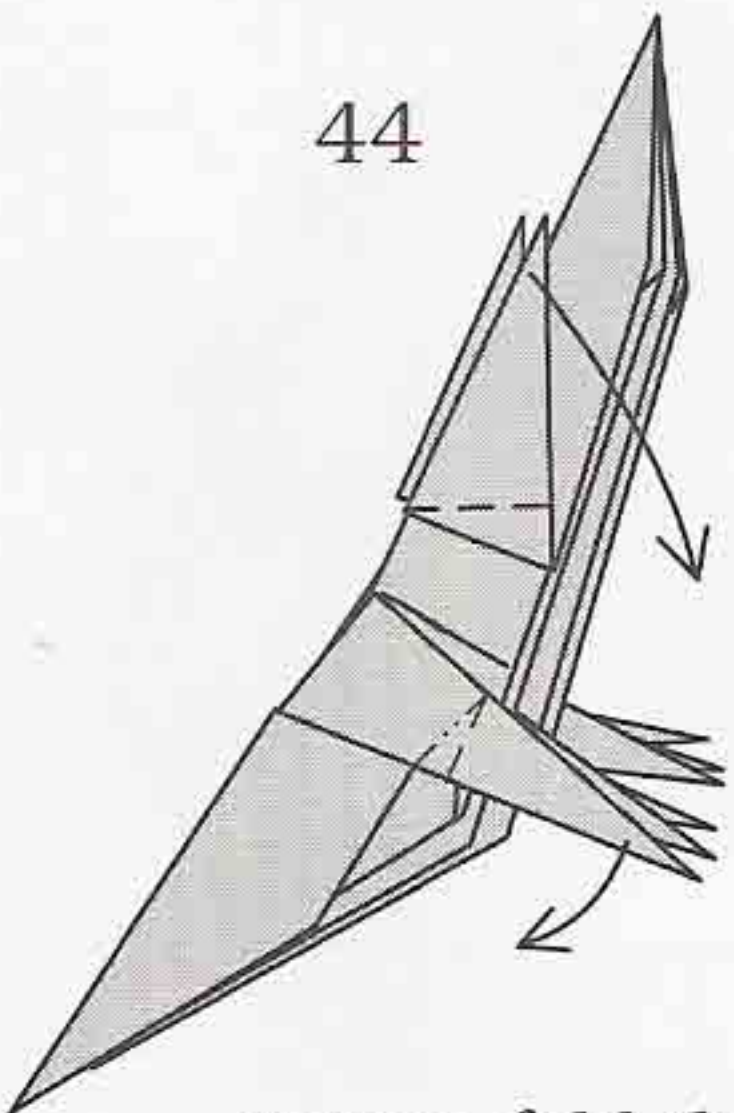

Crimp-fold the legs,
fold the arms down.
Repeat behind.

45

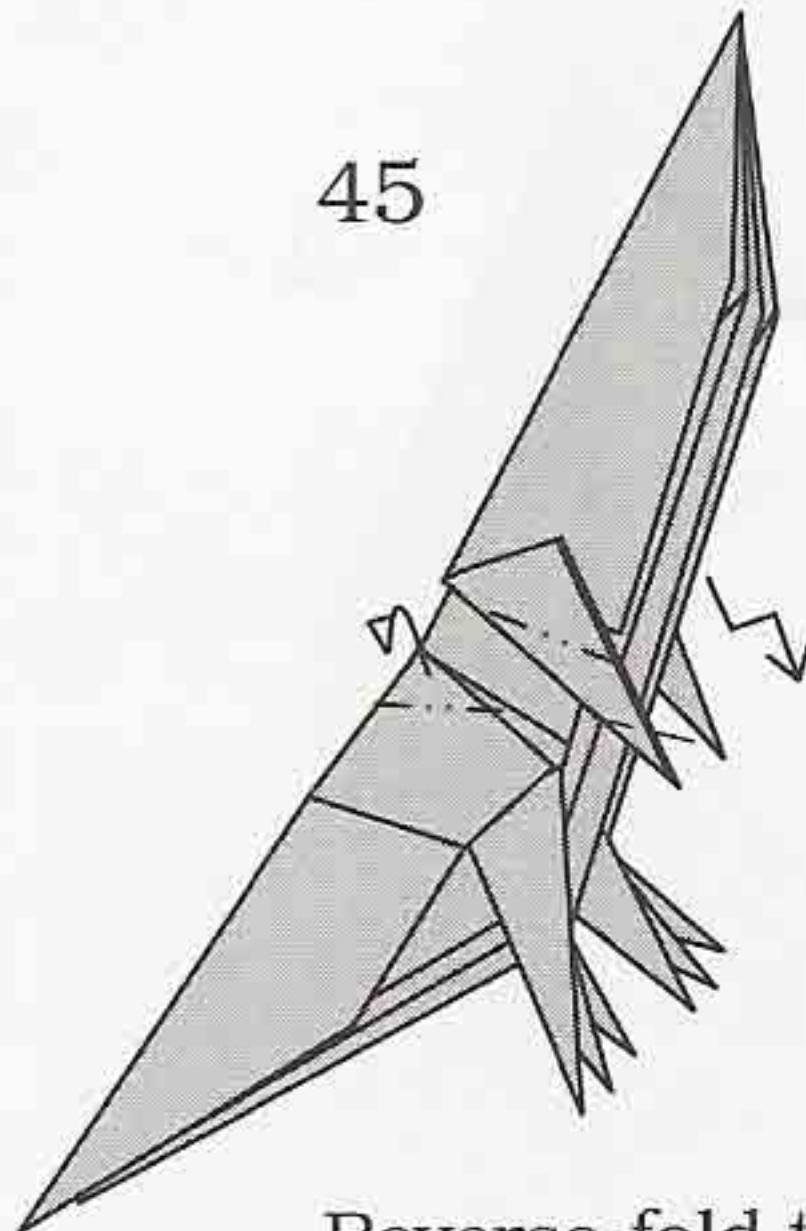

Reverse-fold the arms.
Repeat behind.

46

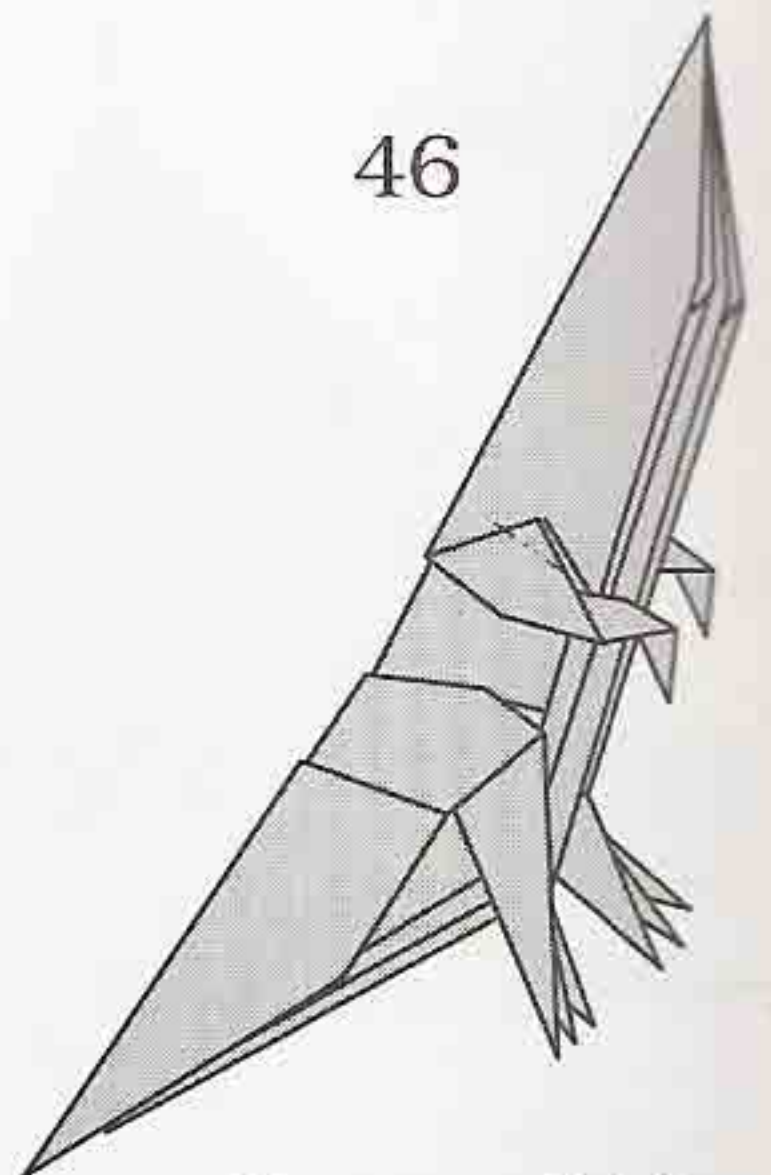

Reverse-fold,
repeat behind.

47

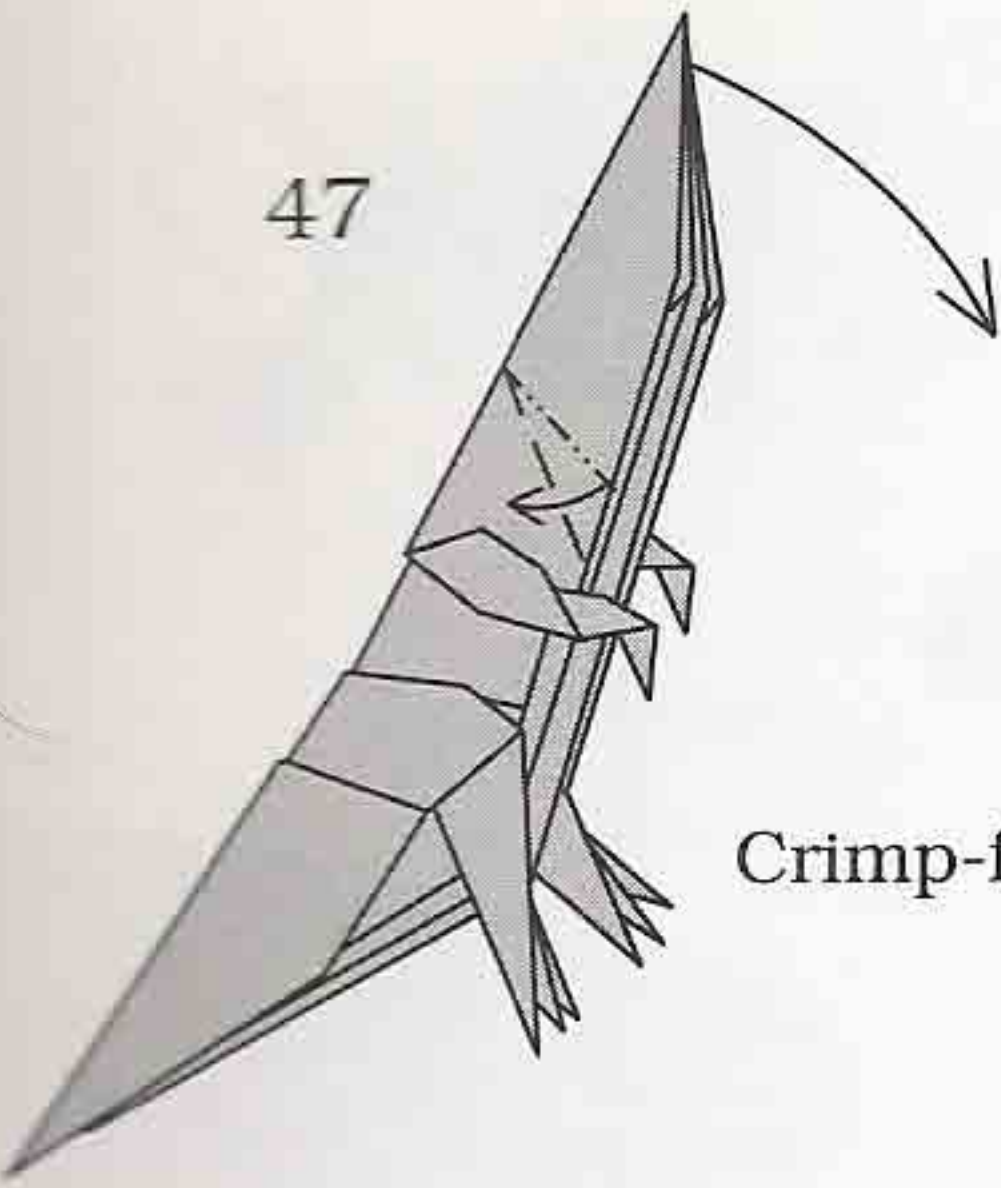

Crimp-fold.

48

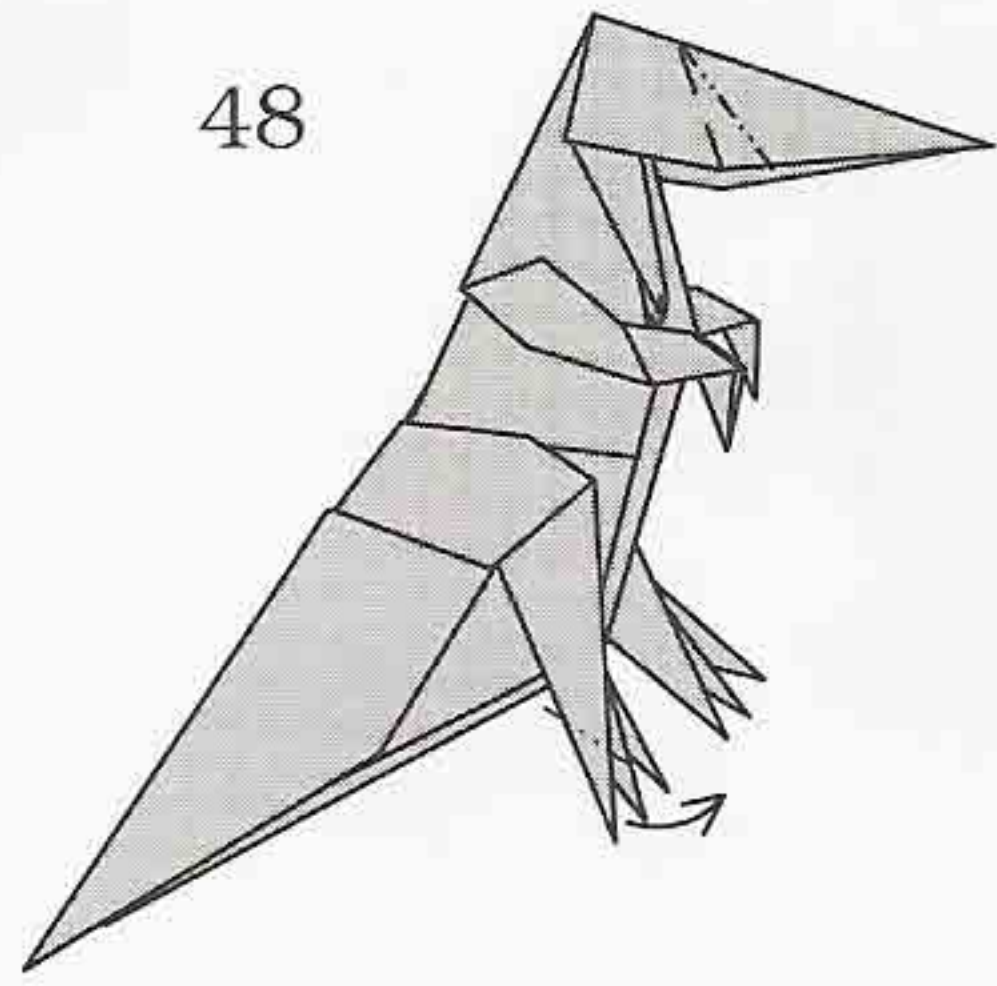

Flatten the head to form a beak. Make reverse folds to form the six toes.

Top view of head.

49

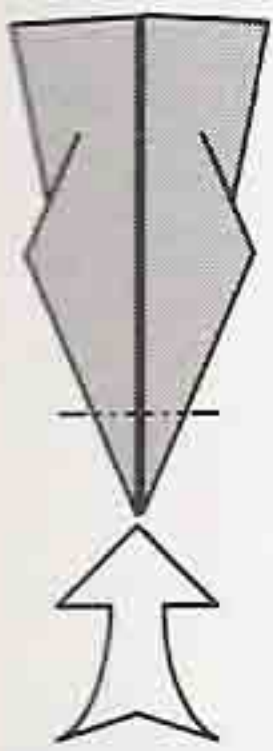

50

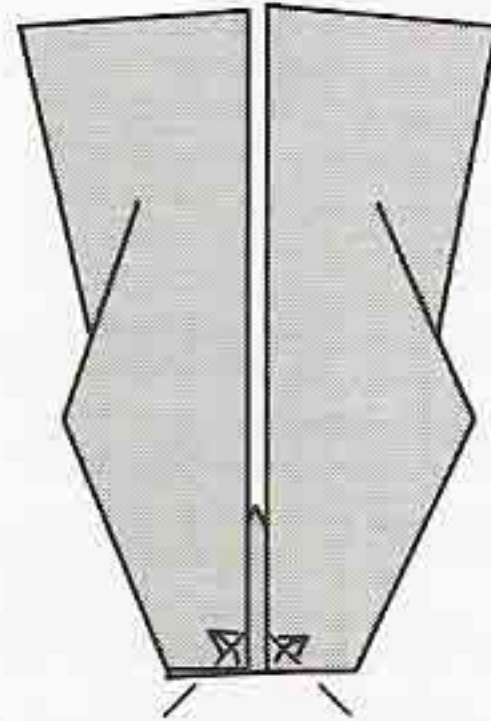

Fold the tip inside.

51

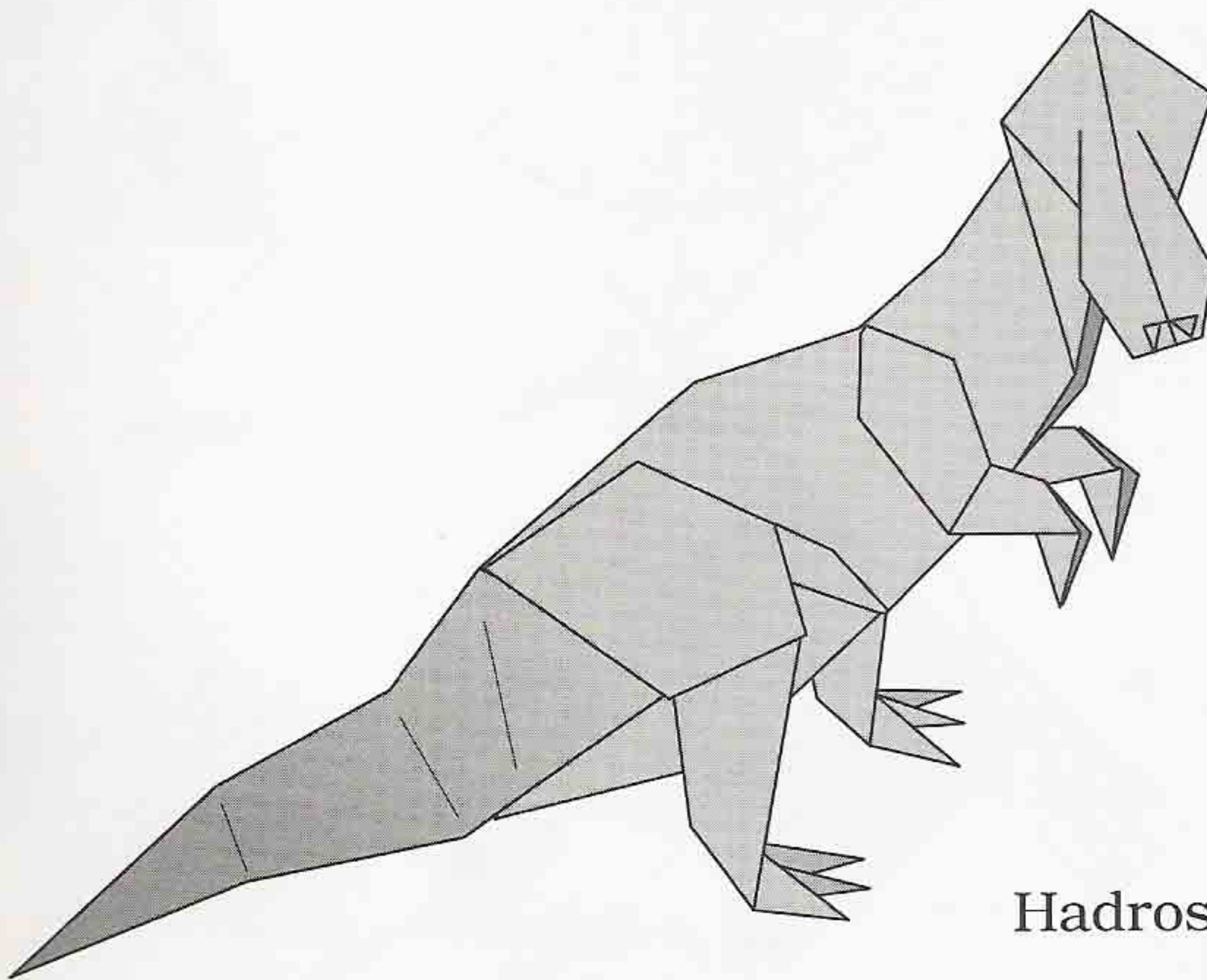
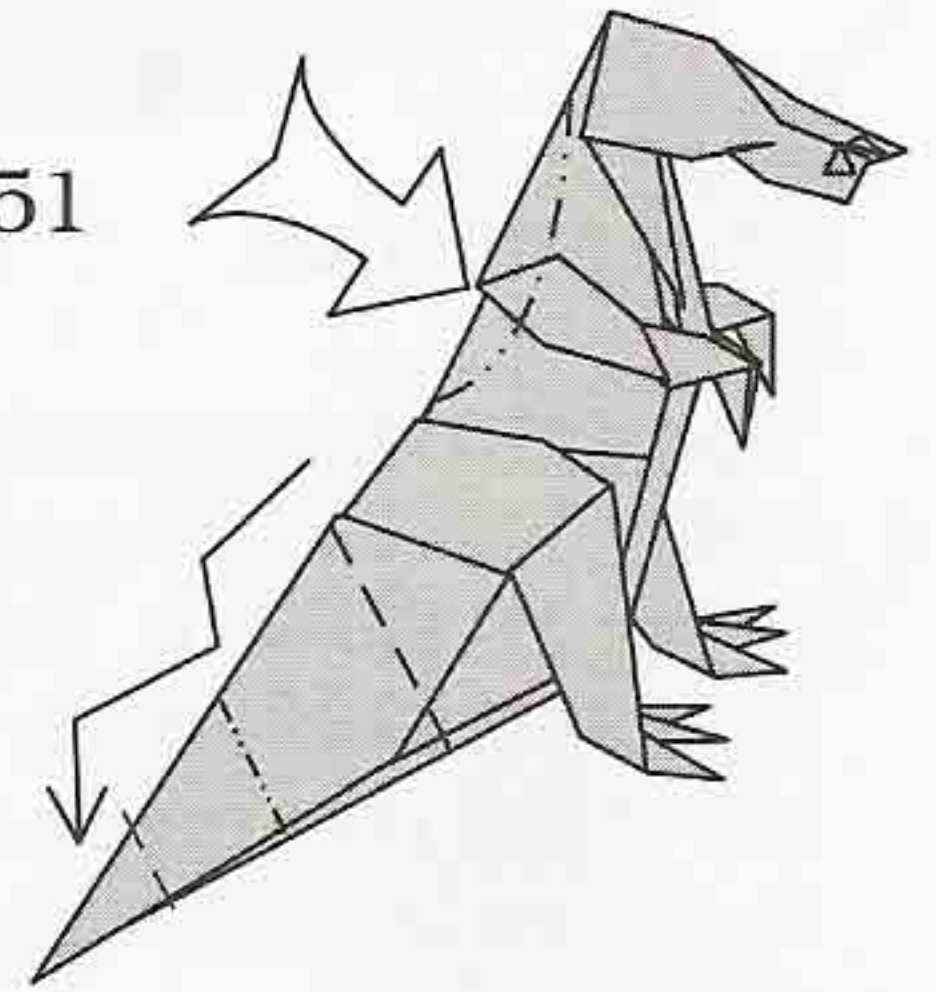

52

Hadrosaurus

Iguanodon

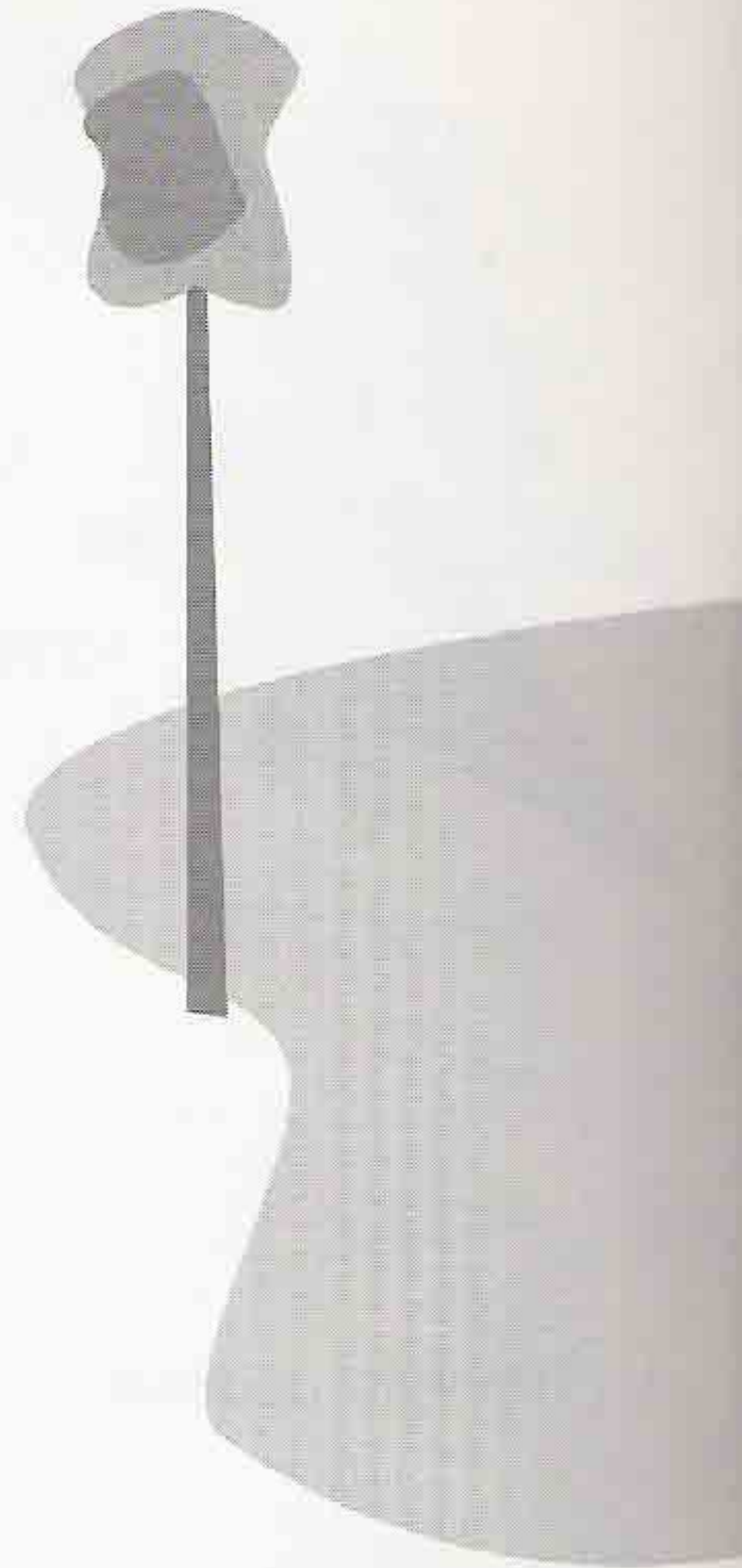
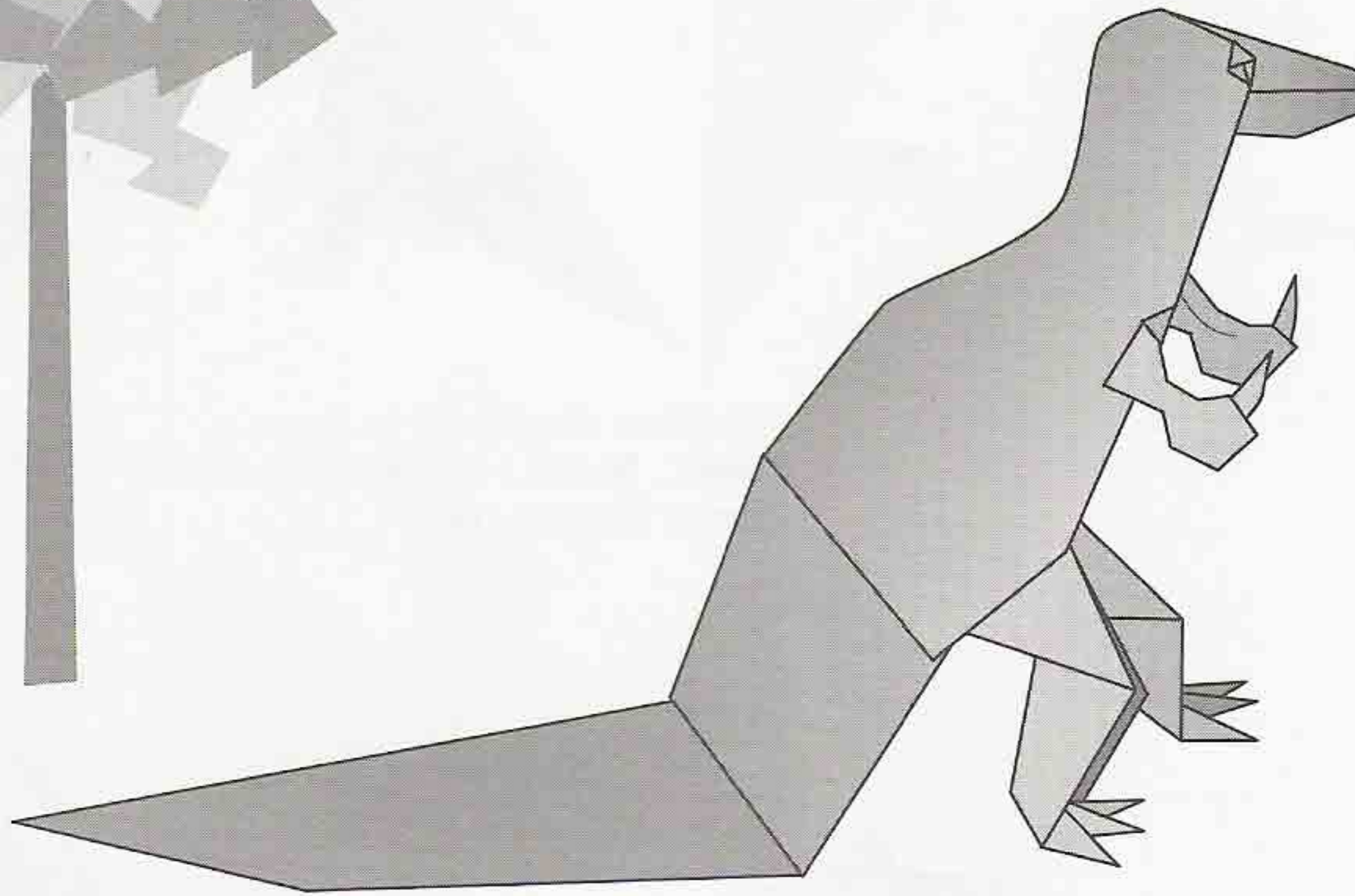

i-GWA-no-don

The most distinguishing feature of this Cretaceous dinosaur is the spike-like thumbs on its front legs. Standing on its hind legs, this reptile stood 16 feet tall. However, it could have also walked on four legs. It had grinding teeth in the back of its mouth and a strong beak with which to break off plants. One of the first dinosaurs ever discovered, fossils were found in Belgium and North Africa. Iguanodon means "iguana tooth".

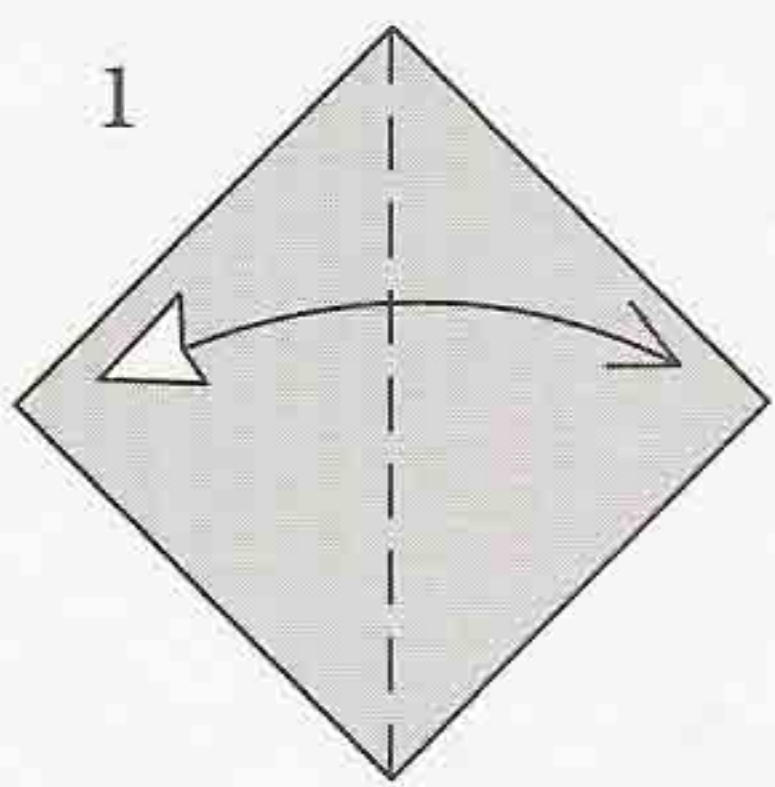

Fold and unfold.

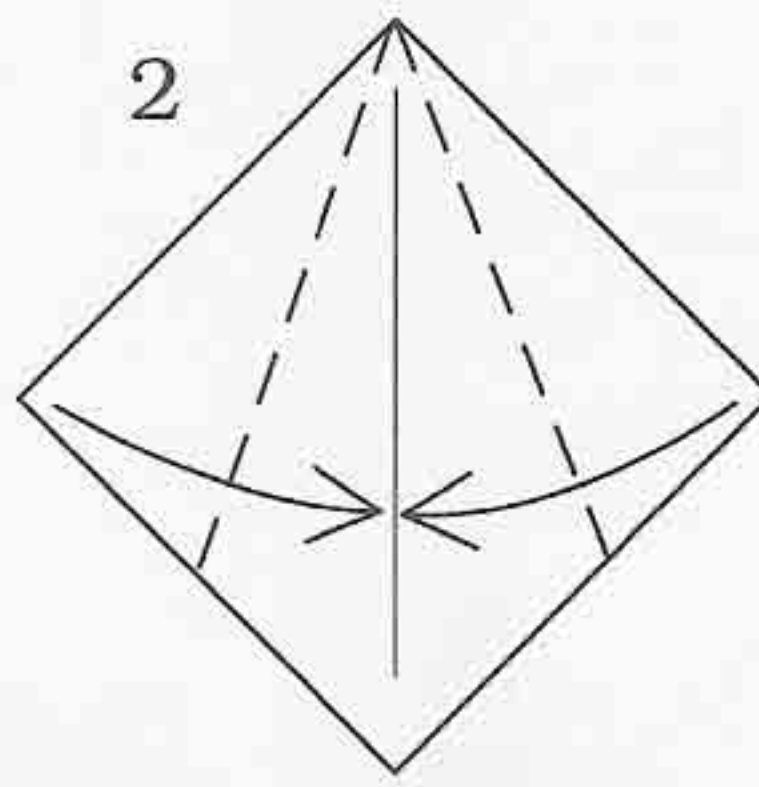
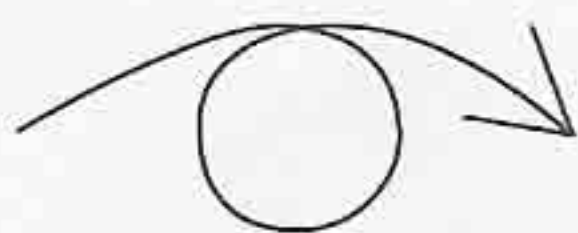

Kite-fold.

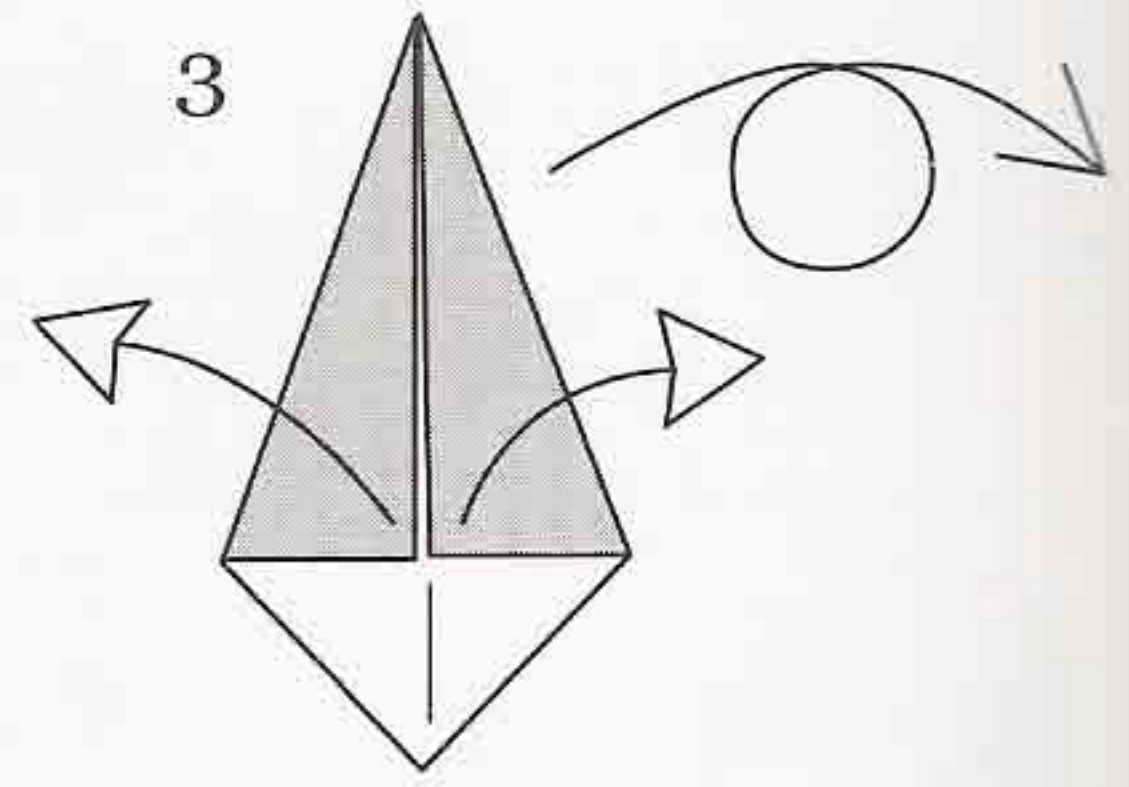

Unfold.

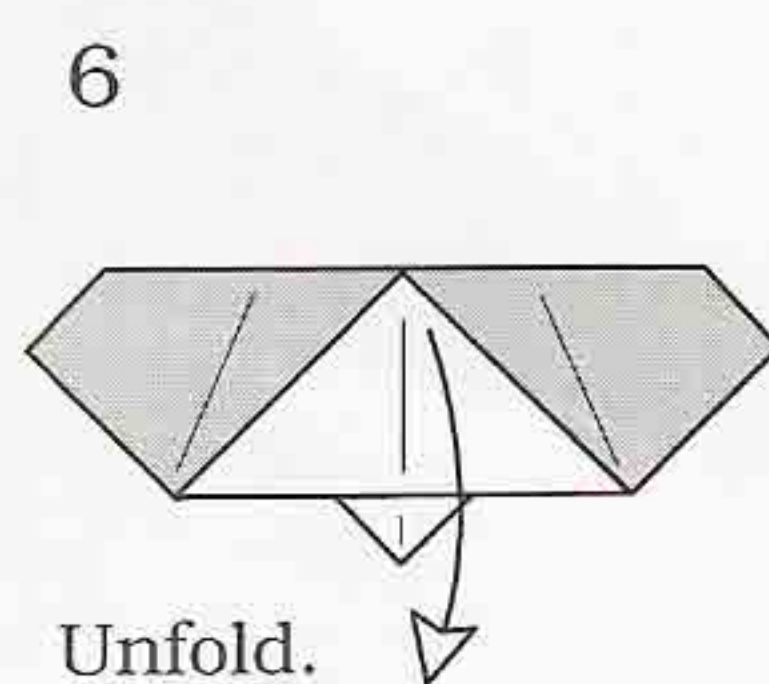
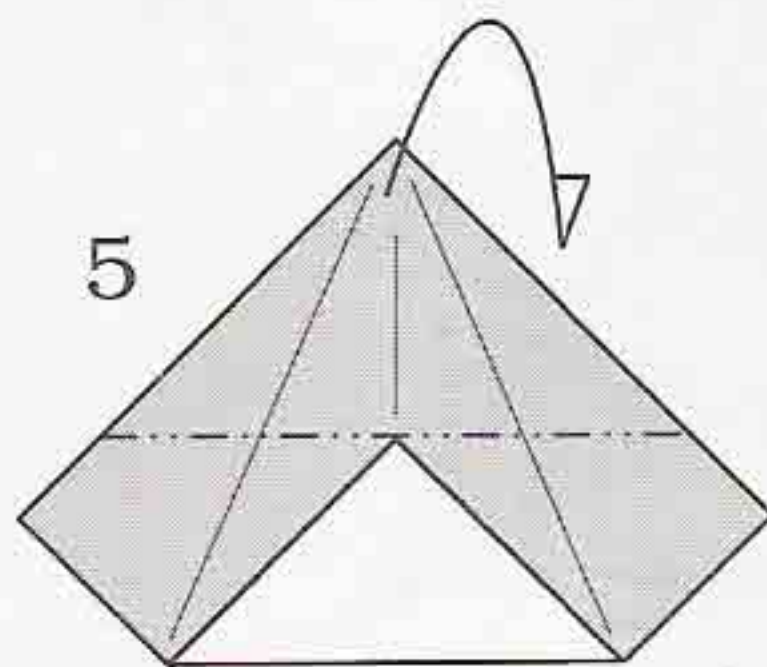
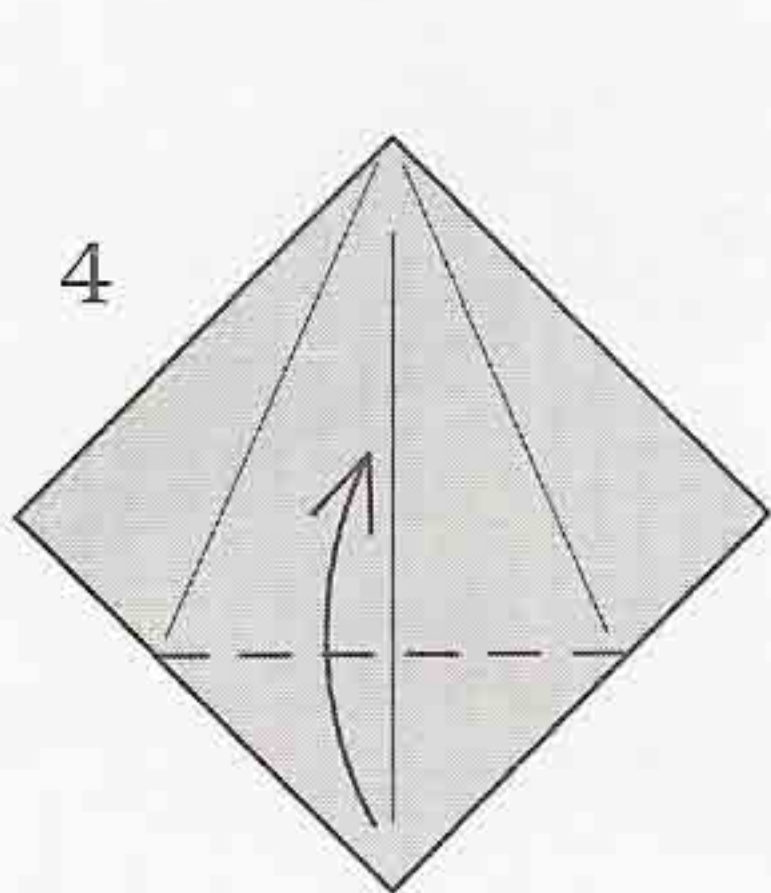

Unfold.

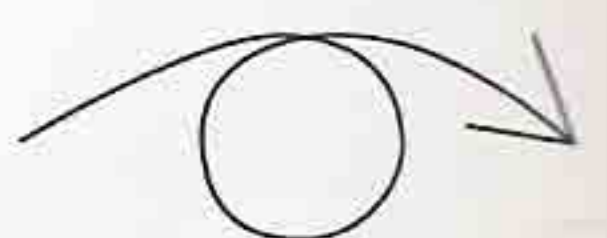

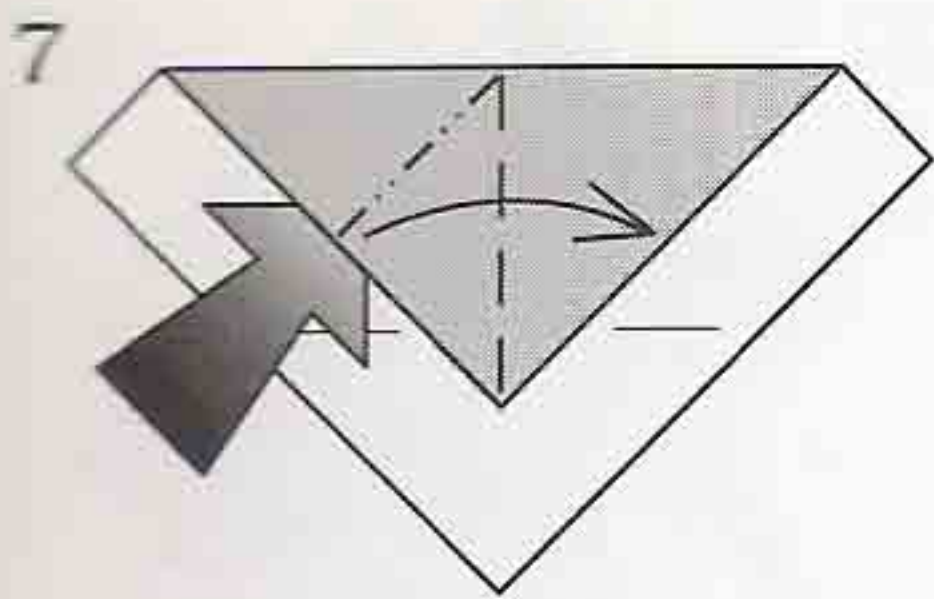

Squash-fold.

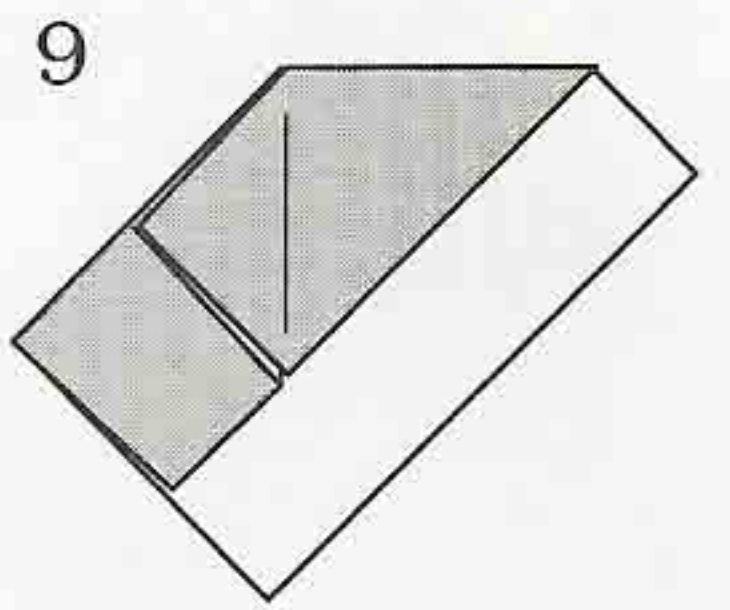
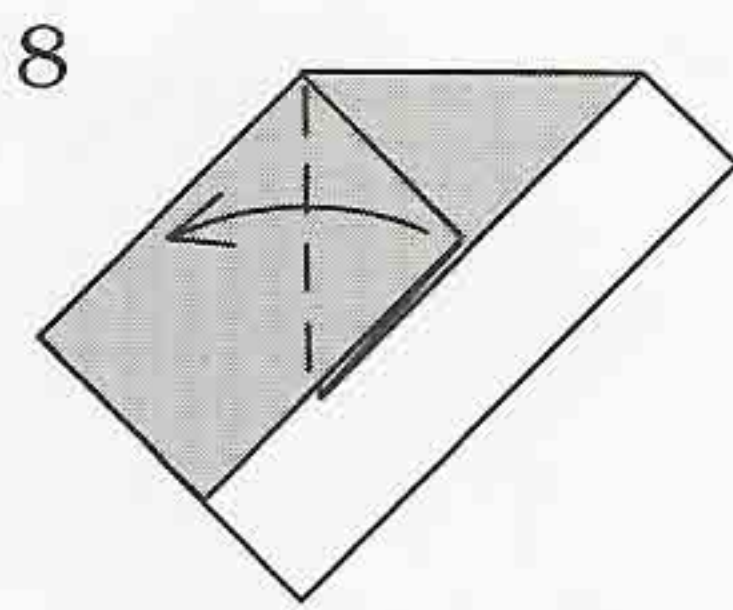

Repeat steps 7-8 on the right.

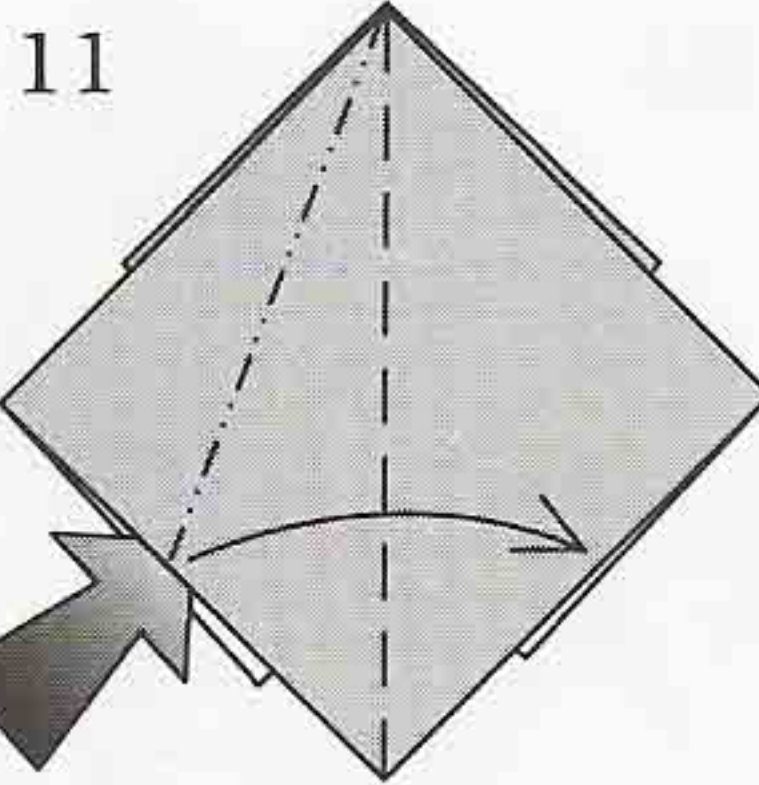
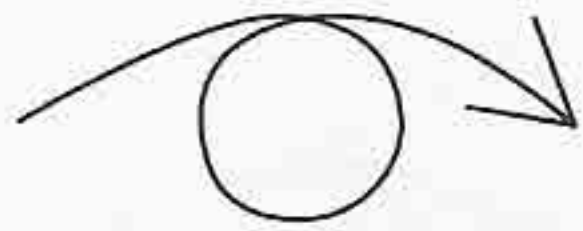
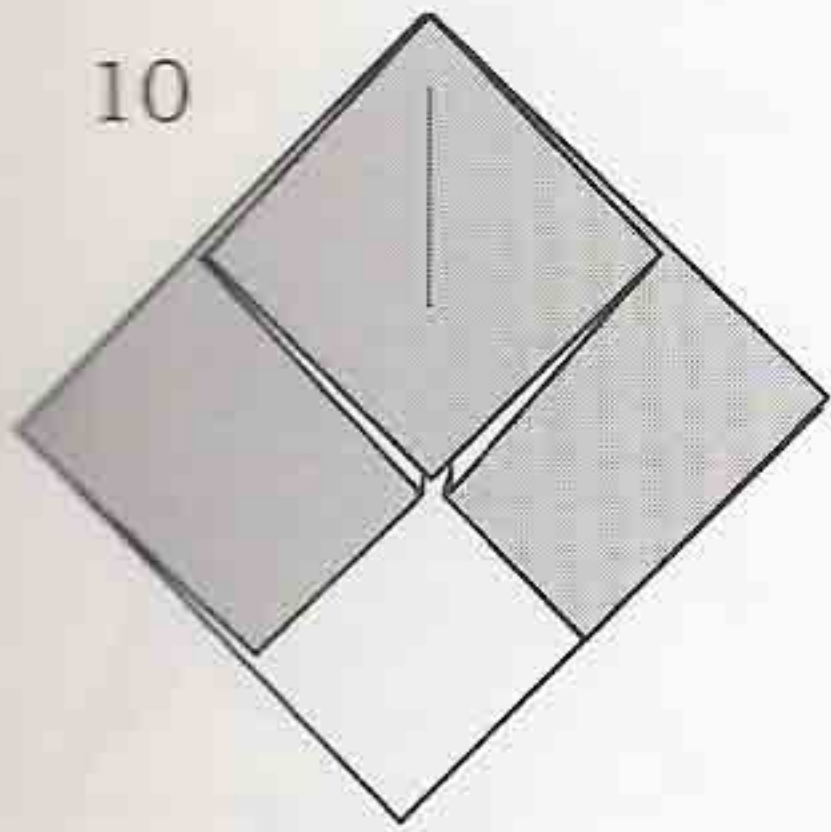

Squash-fold.

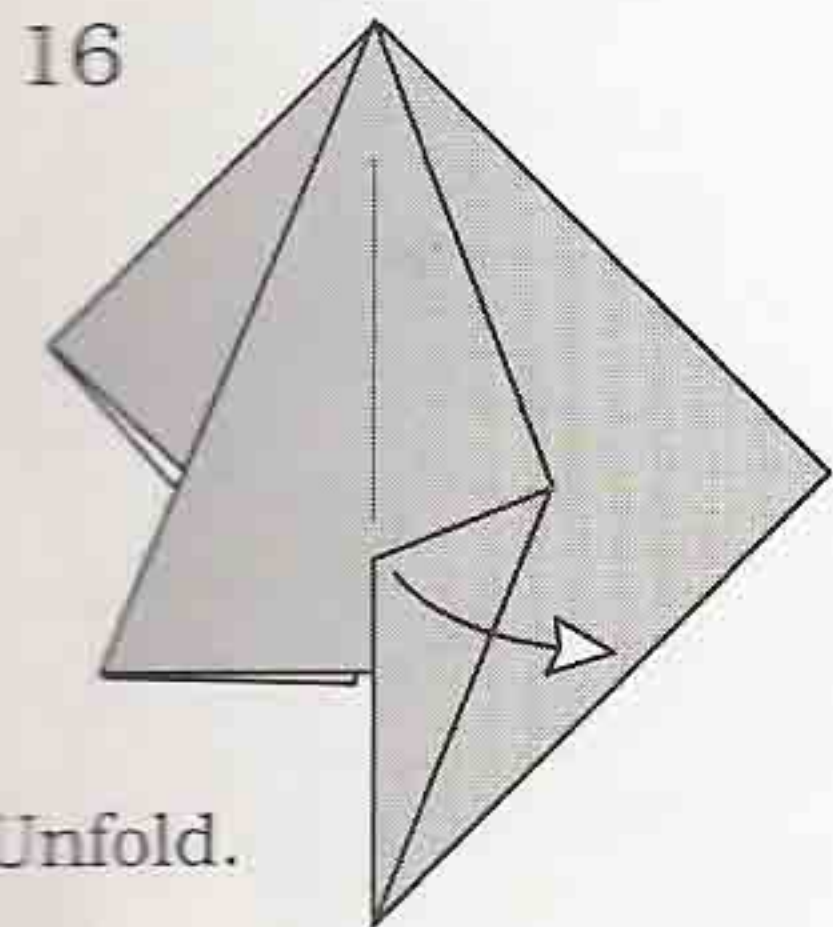
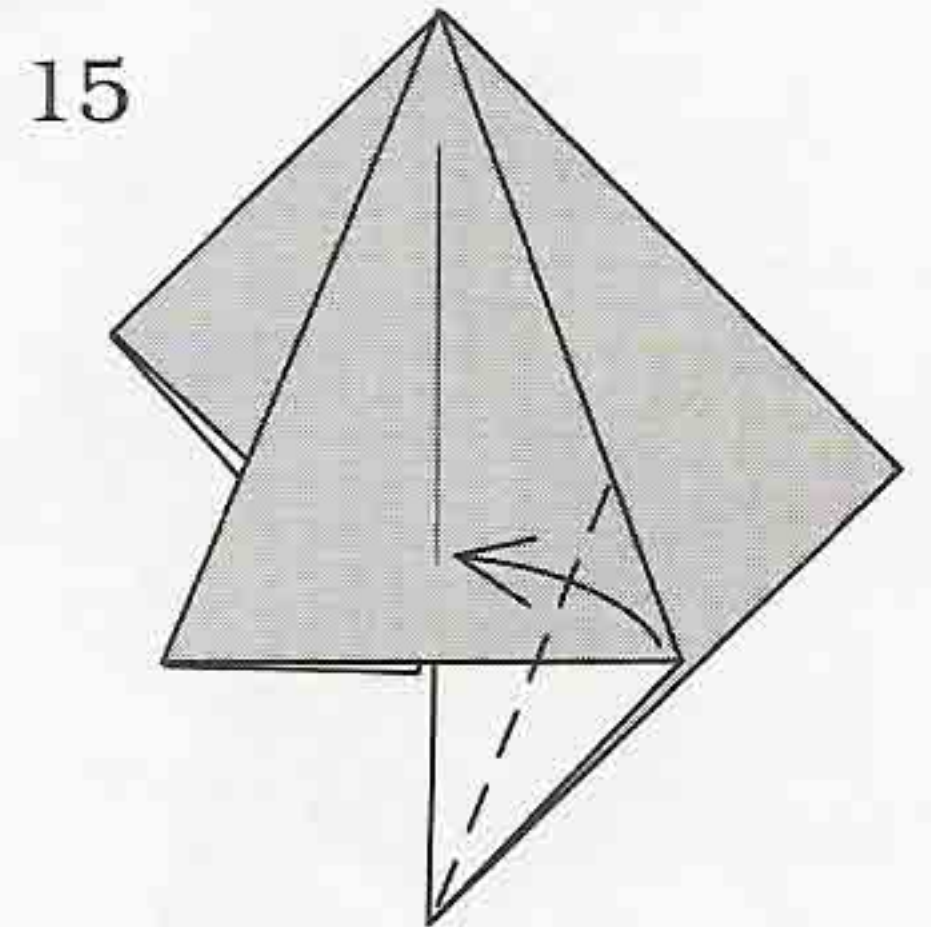
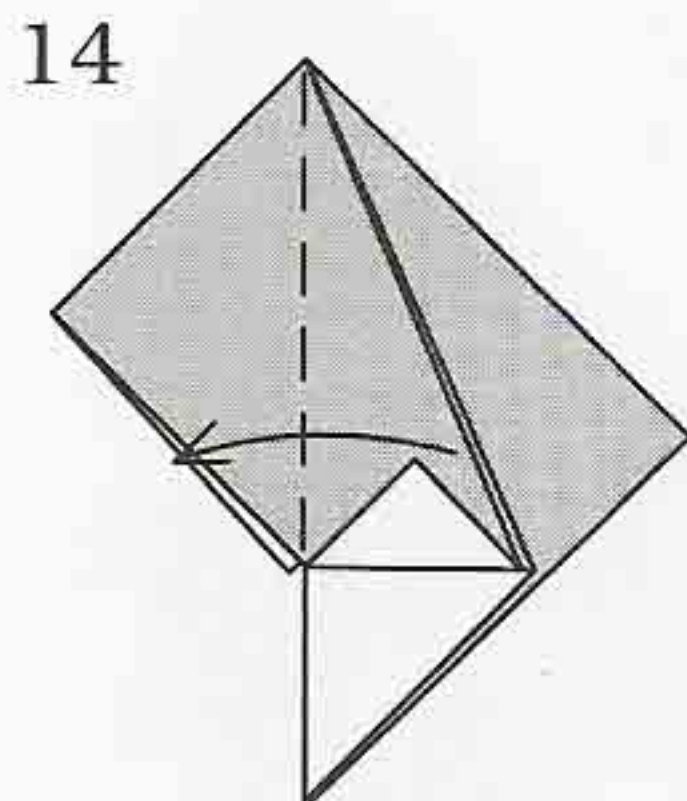
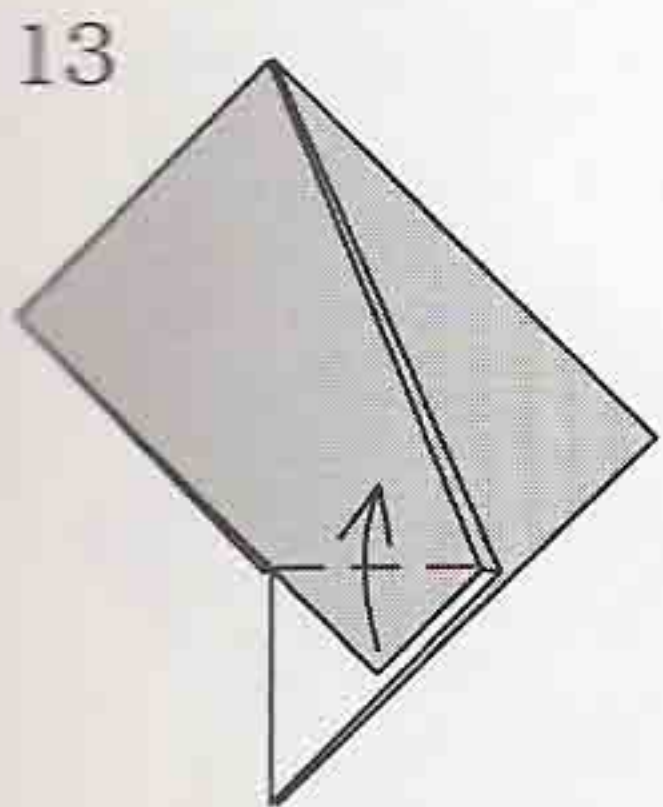
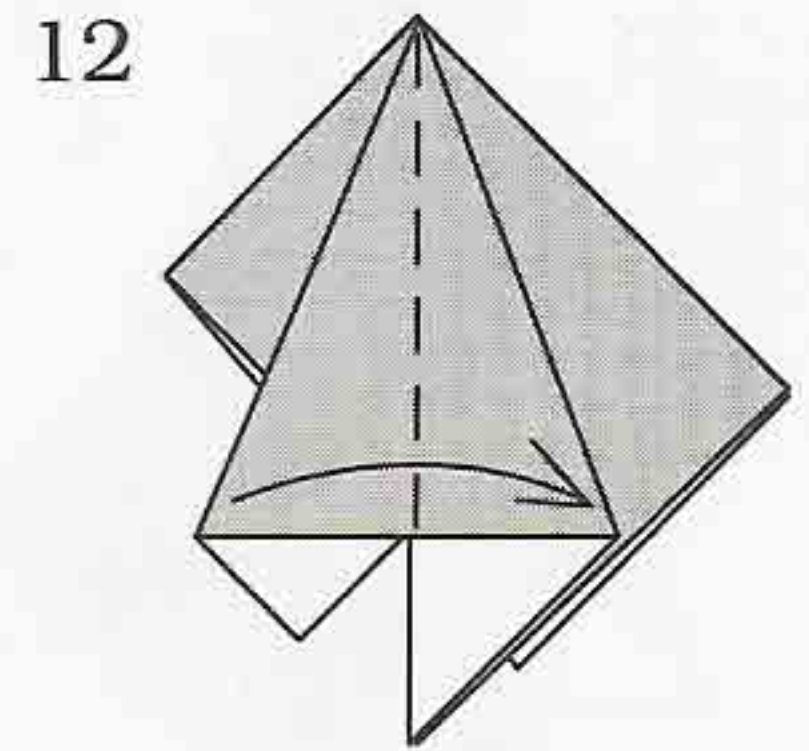

Unfold.

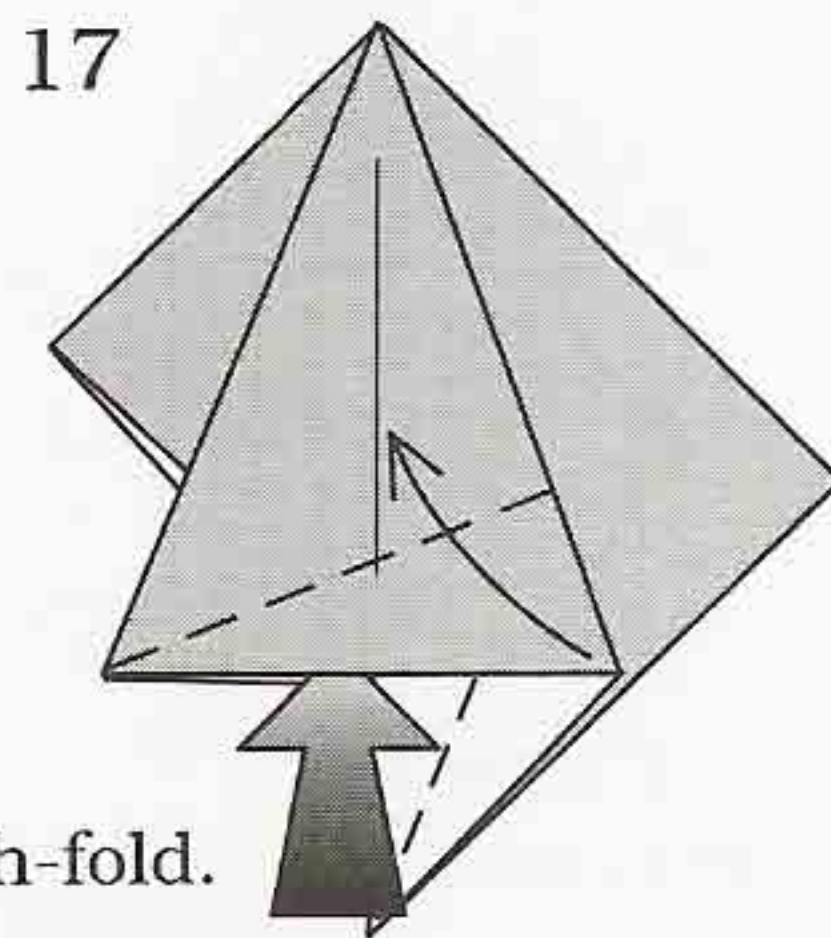

Squash-fold.

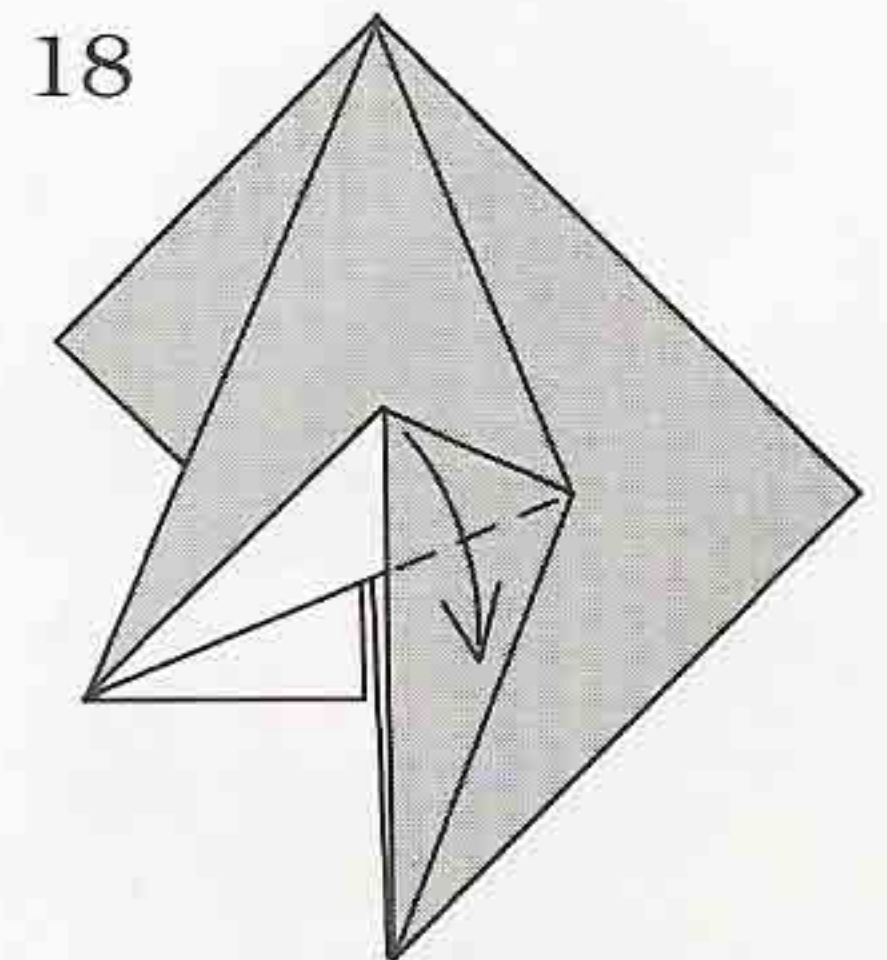

19

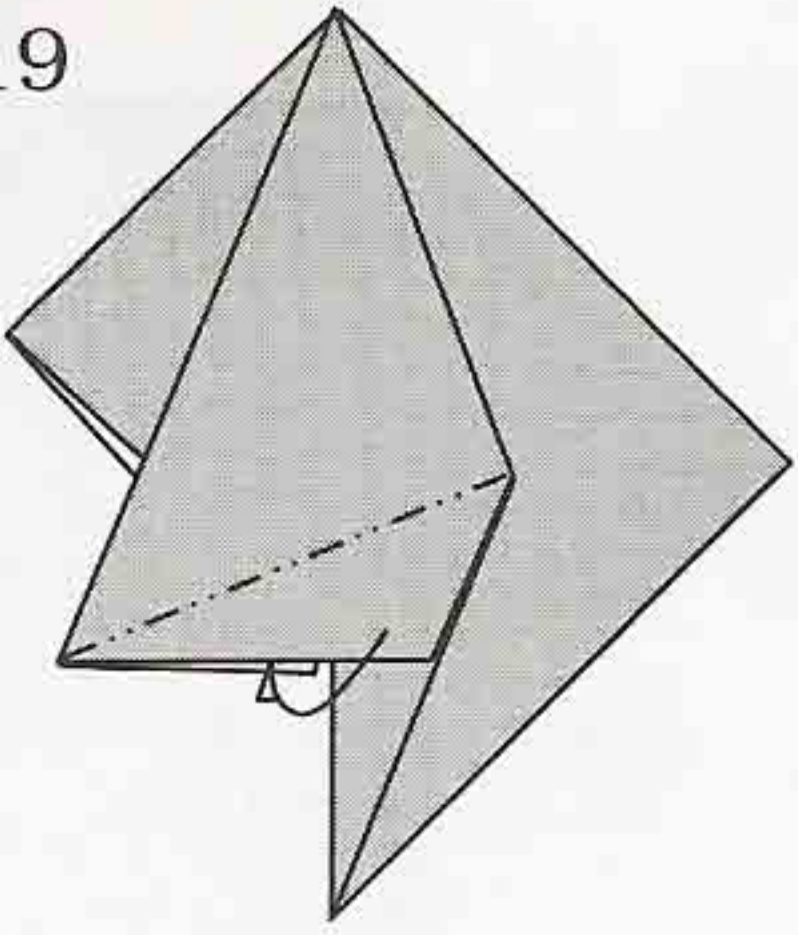

20

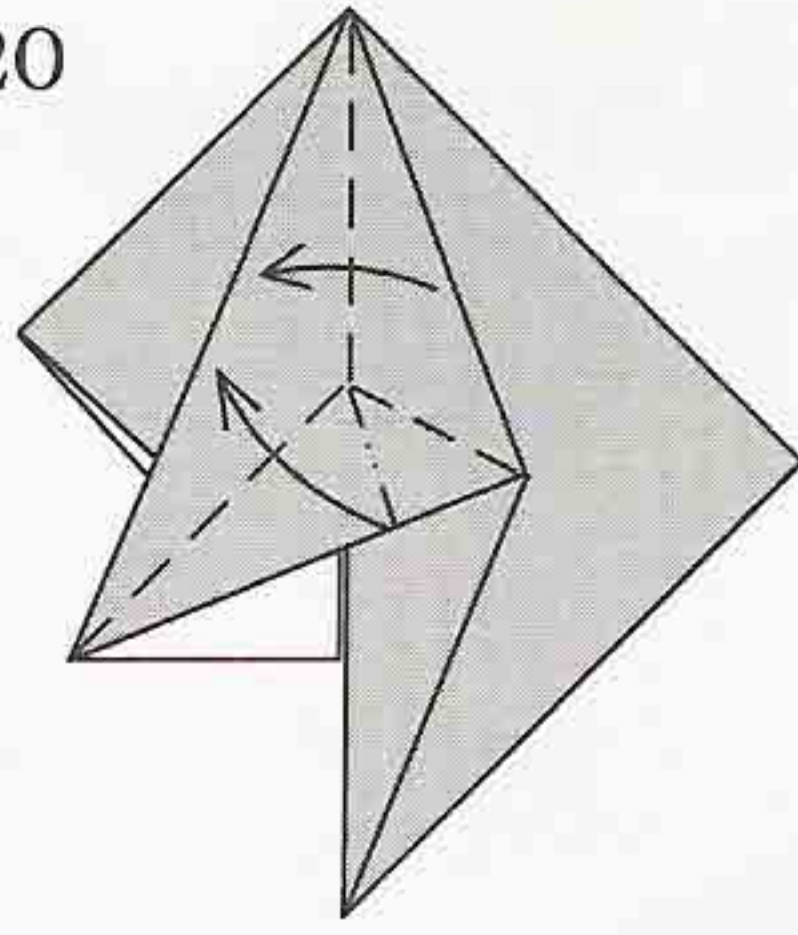

21

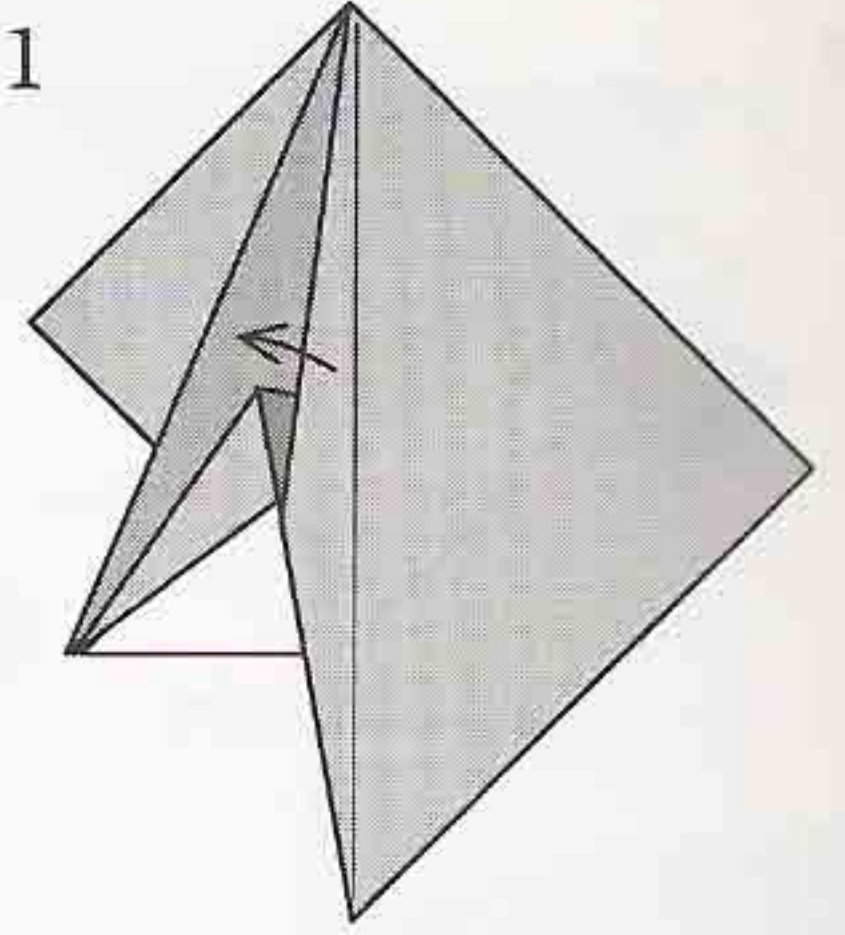

An intermediate step.

22

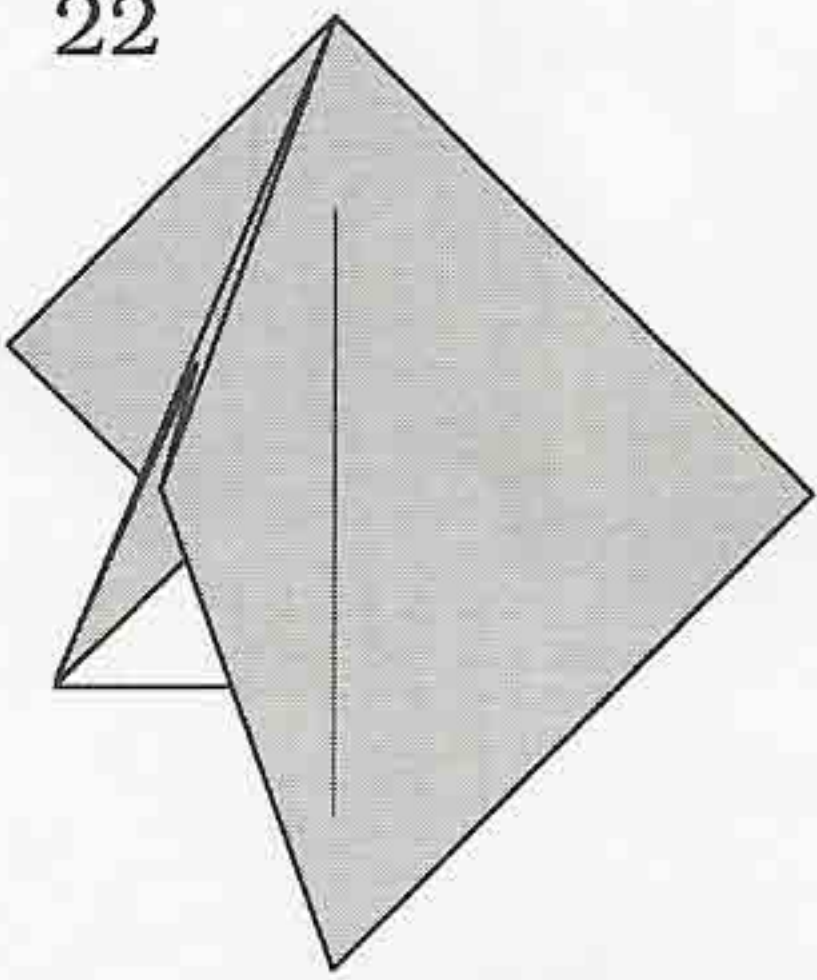

23

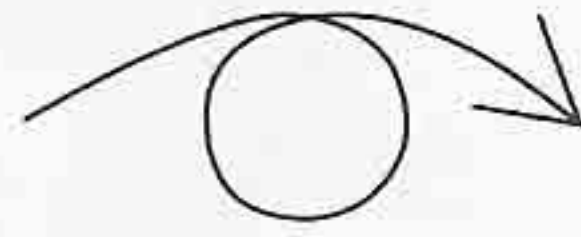
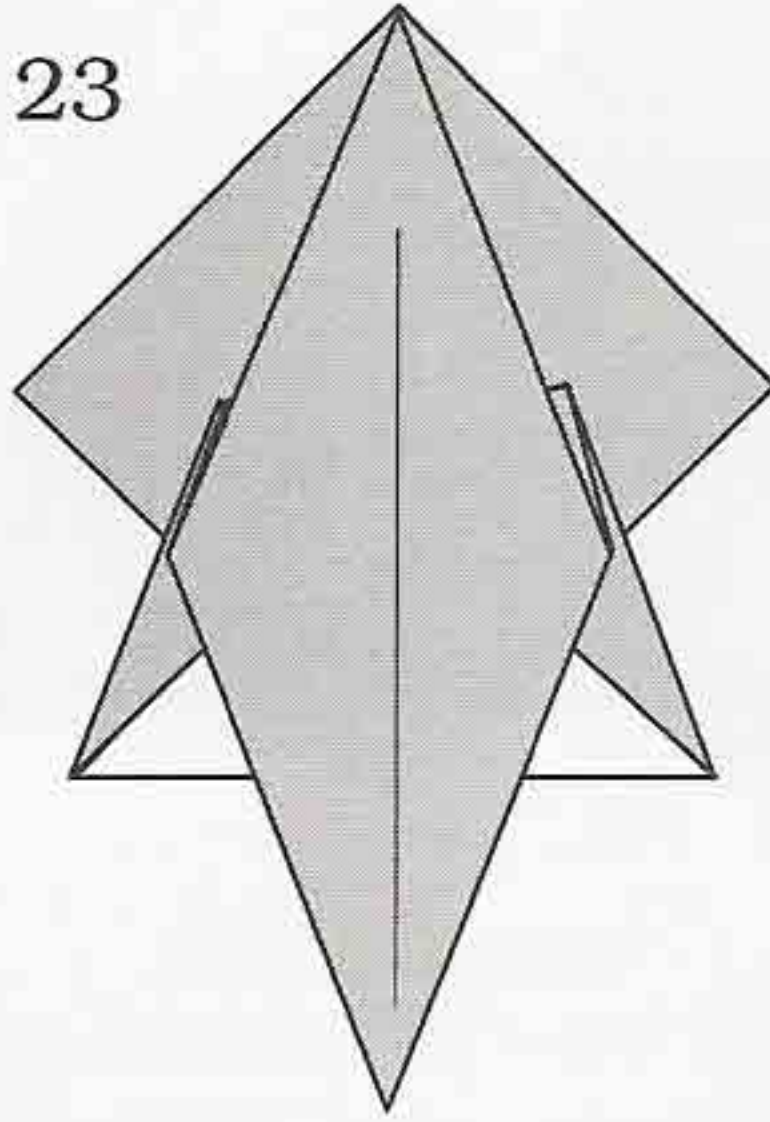

24

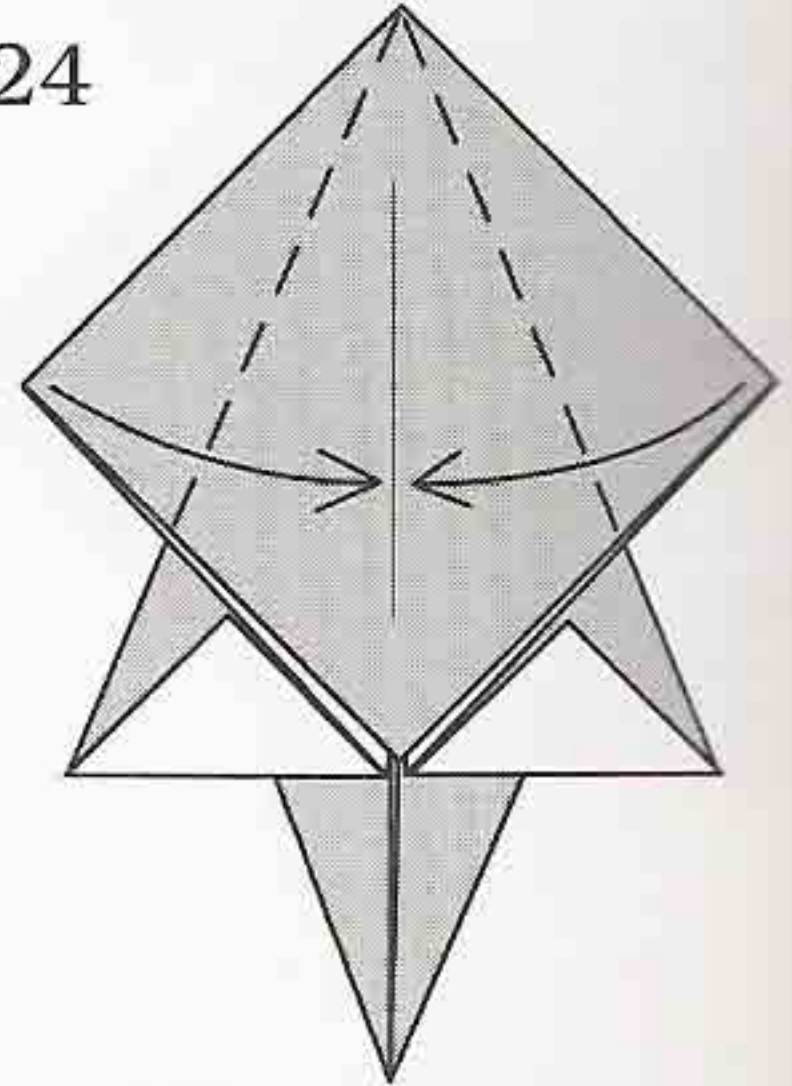

Repeat steps 11-21 on the right.

25

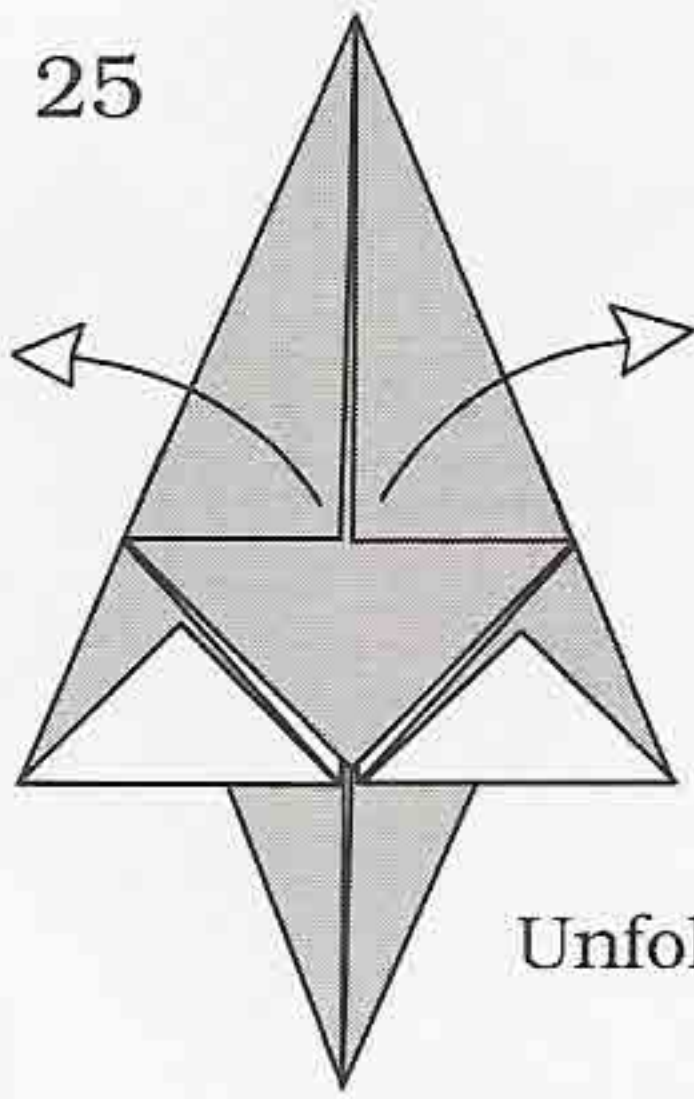

Unfold.

26

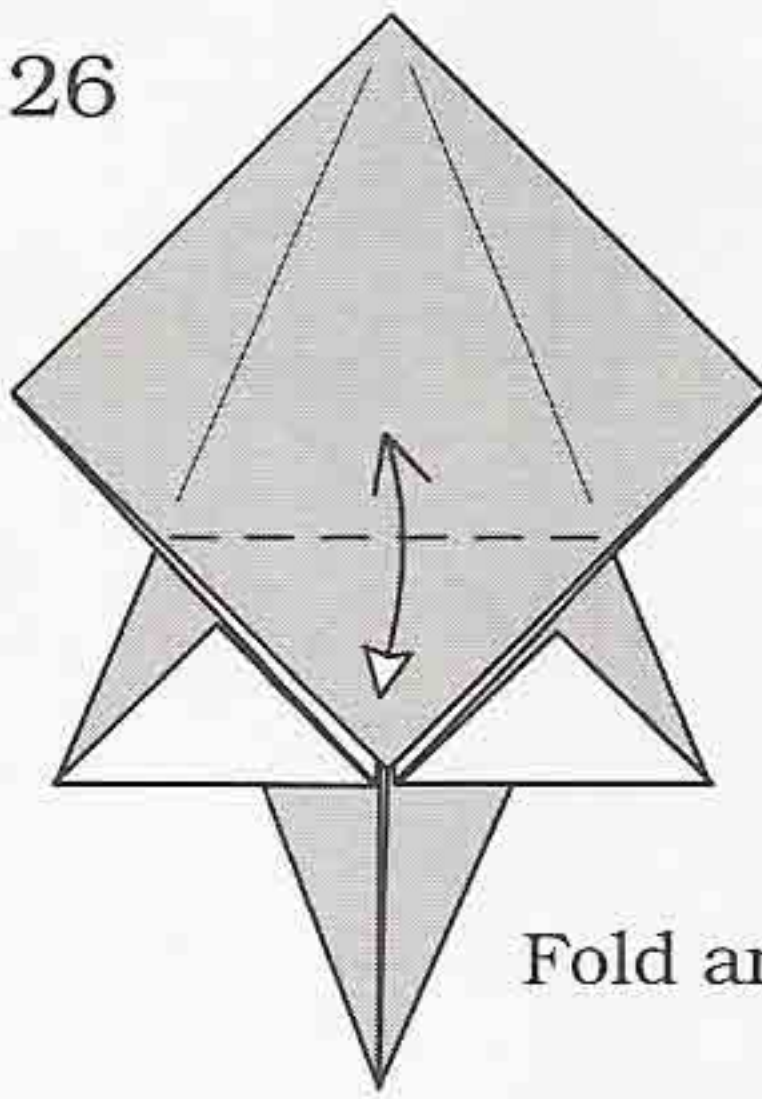

Fold and unfold.

27

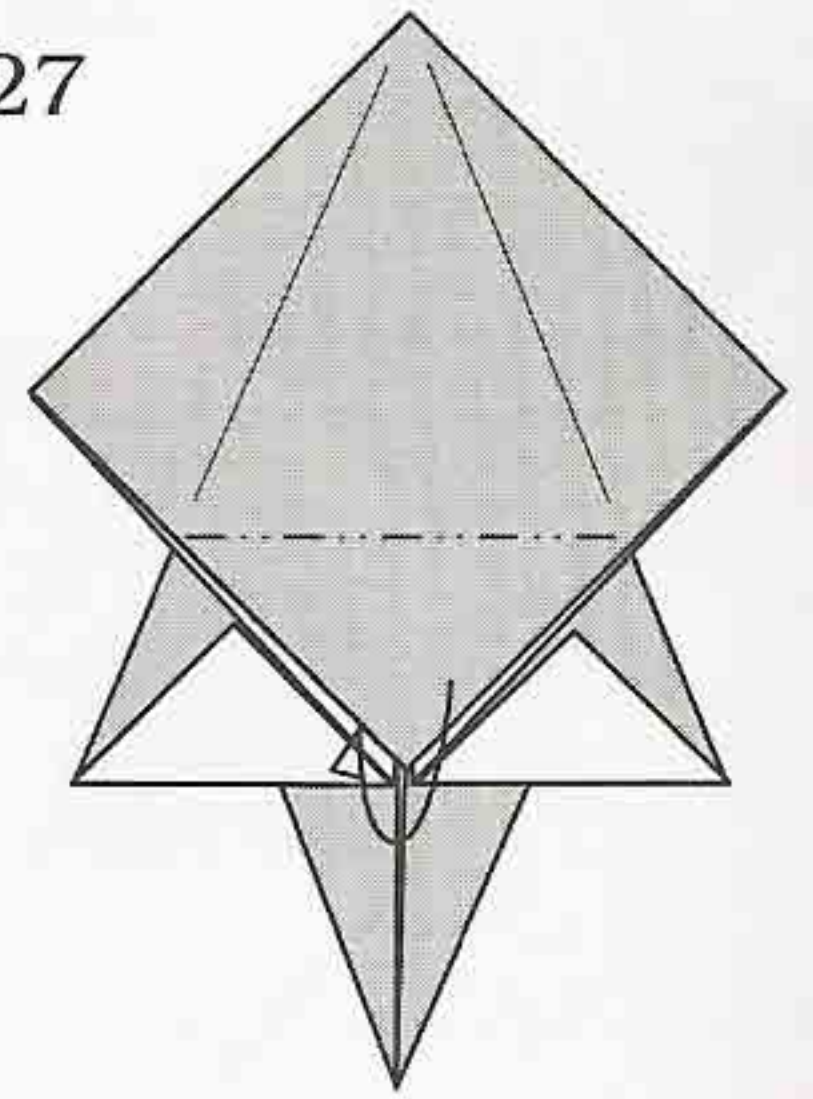

28

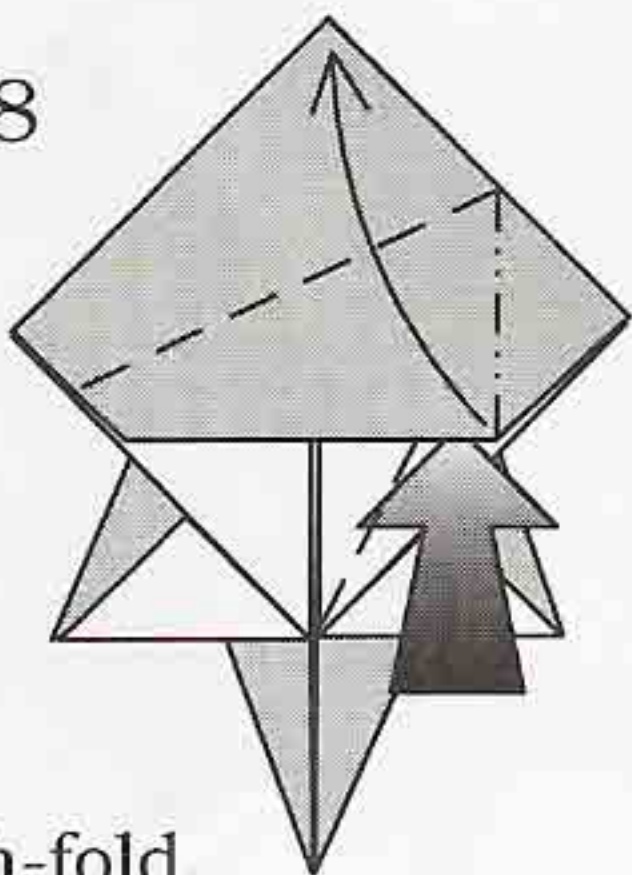

Squash-fold.

29

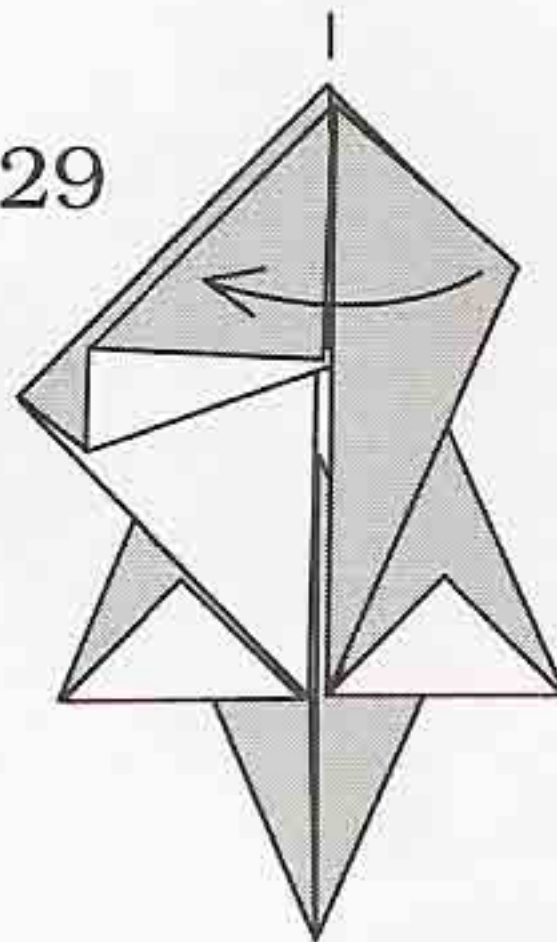

30

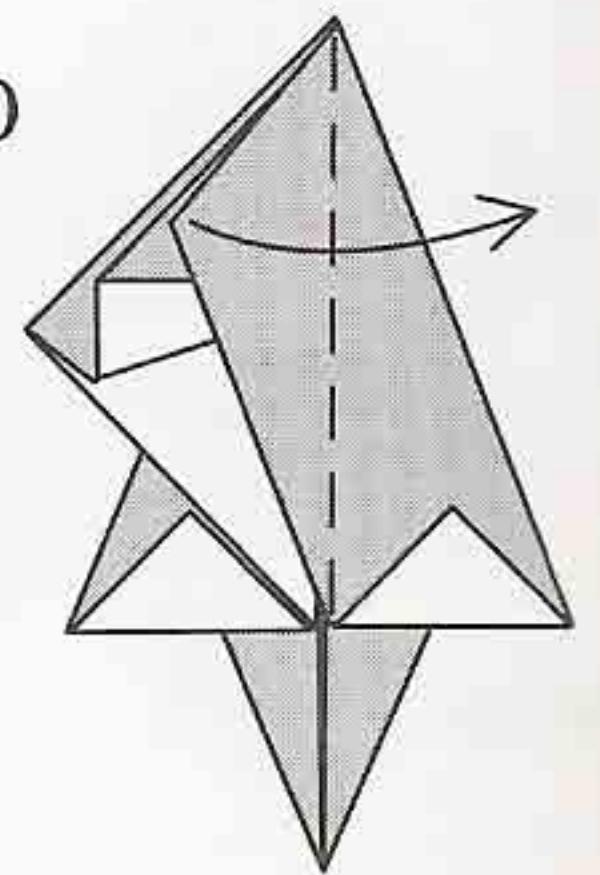

31

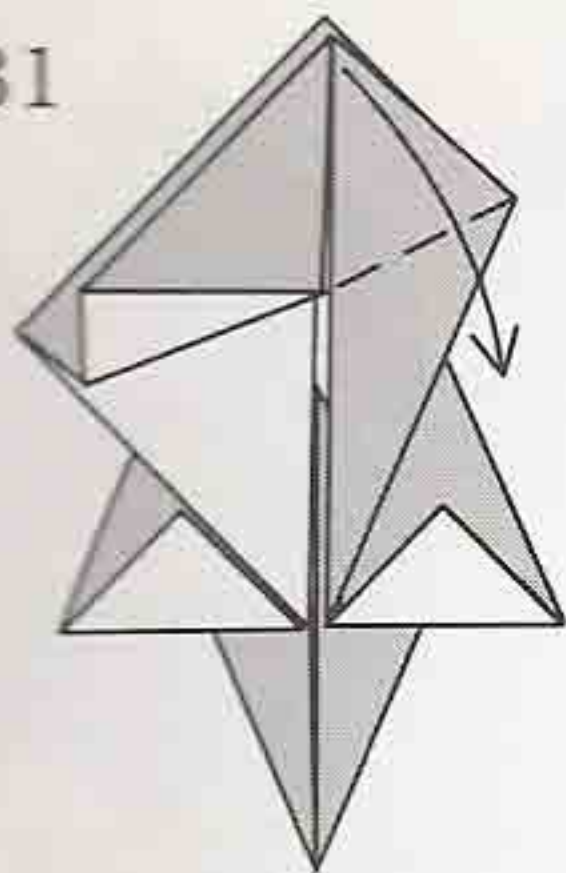

32

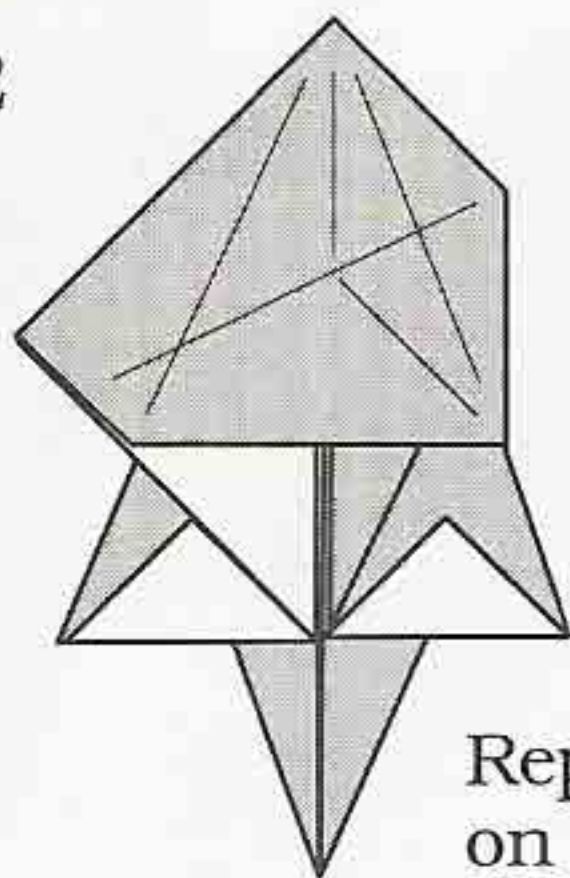

Repeat steps 28-31 on the left.

33

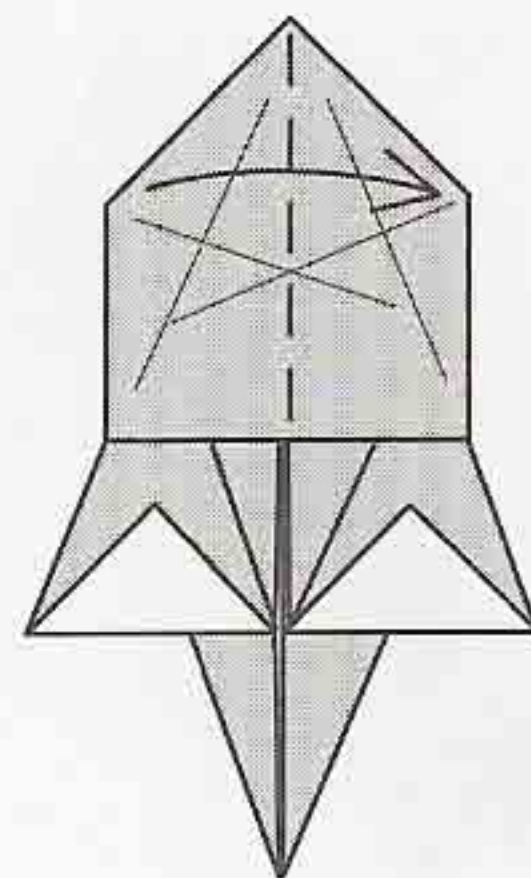

34

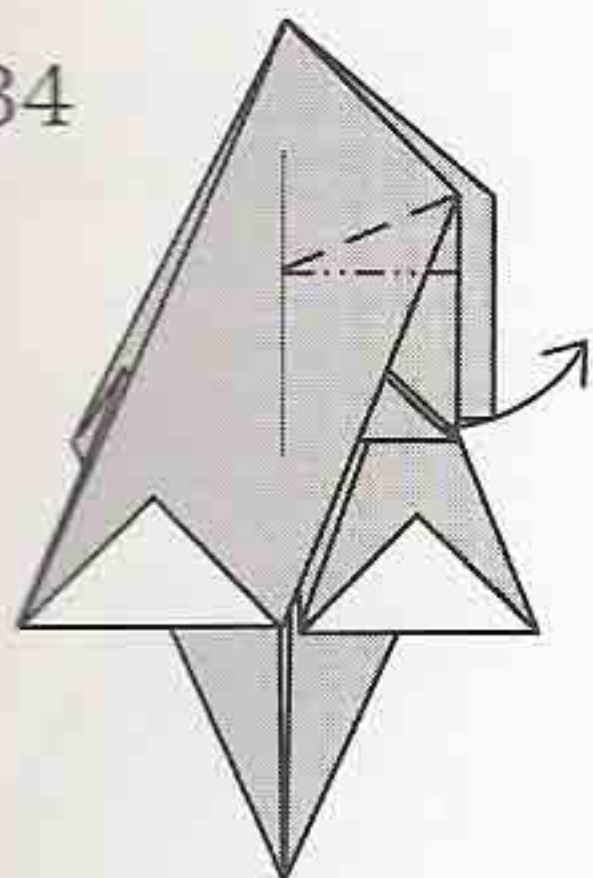

Crimp-fold.

35

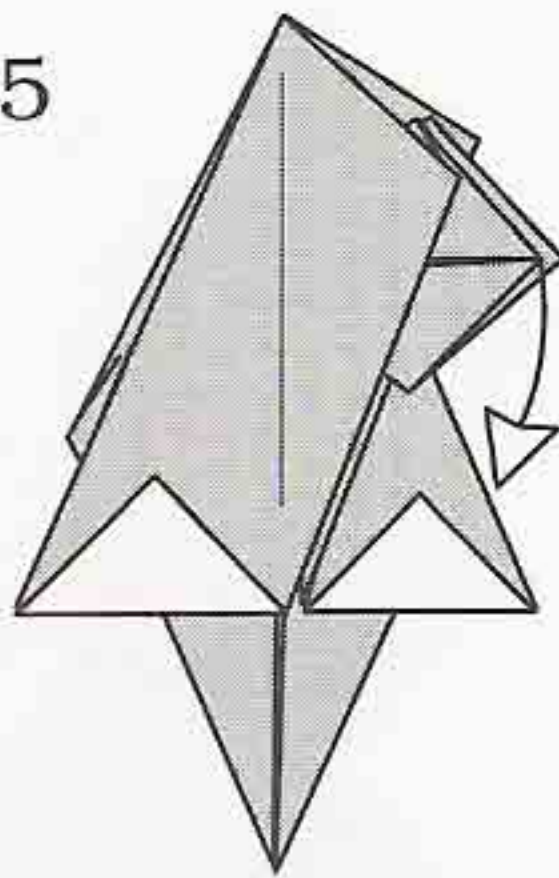

Unfold.

36

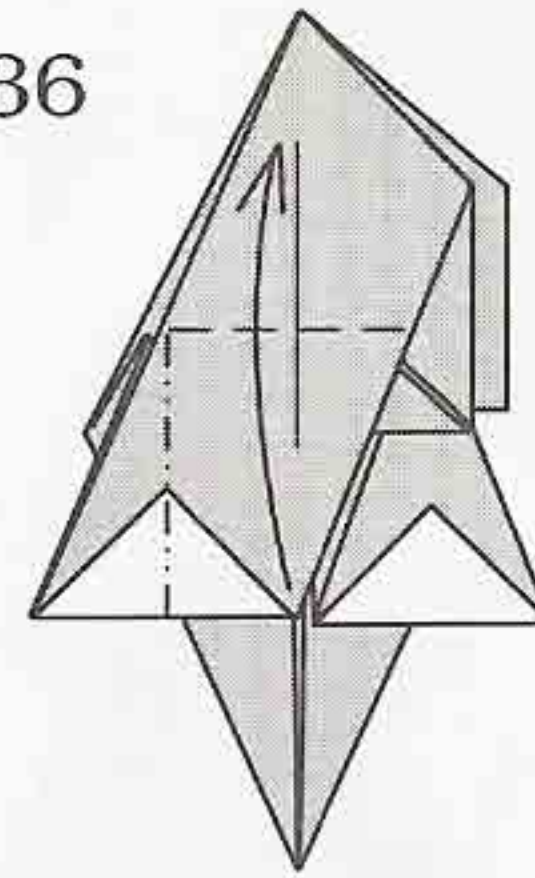

Squash-fold.

37

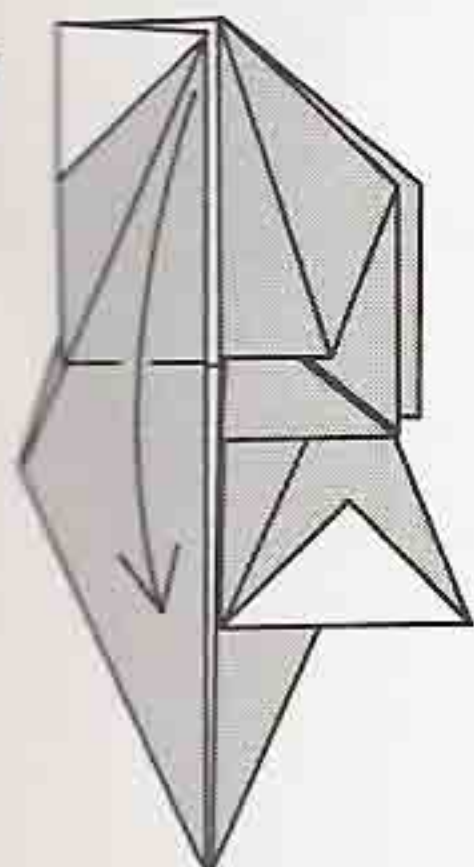

38

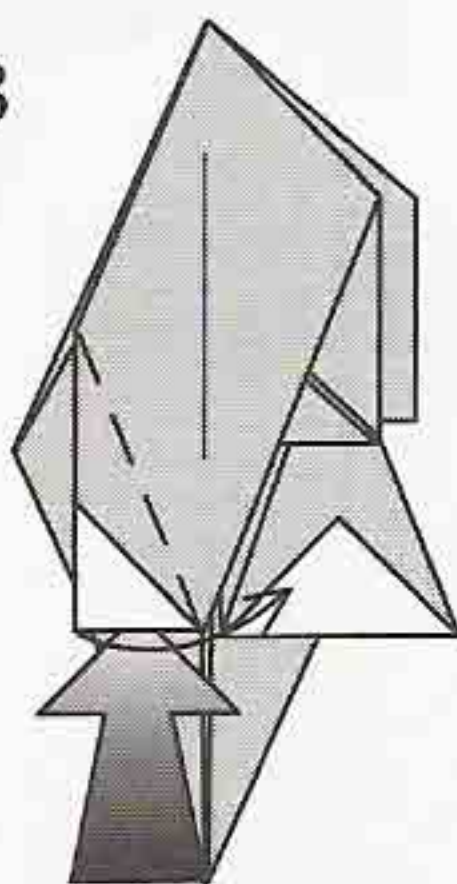

Reverse-fold.

39

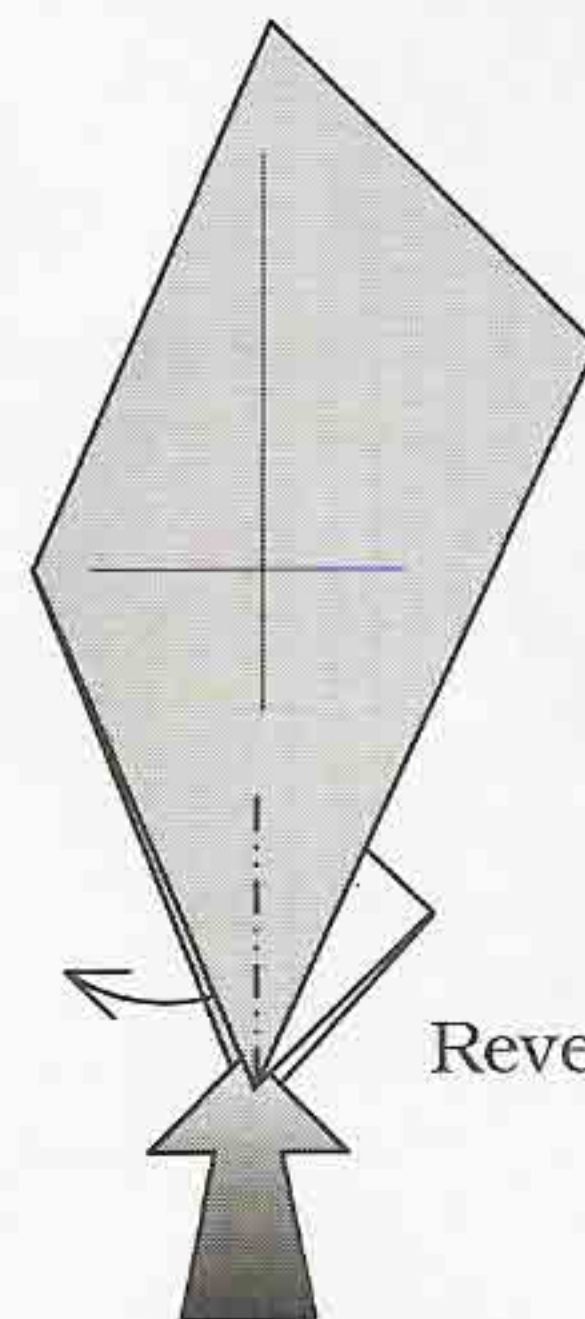

Reverse-fold.

40

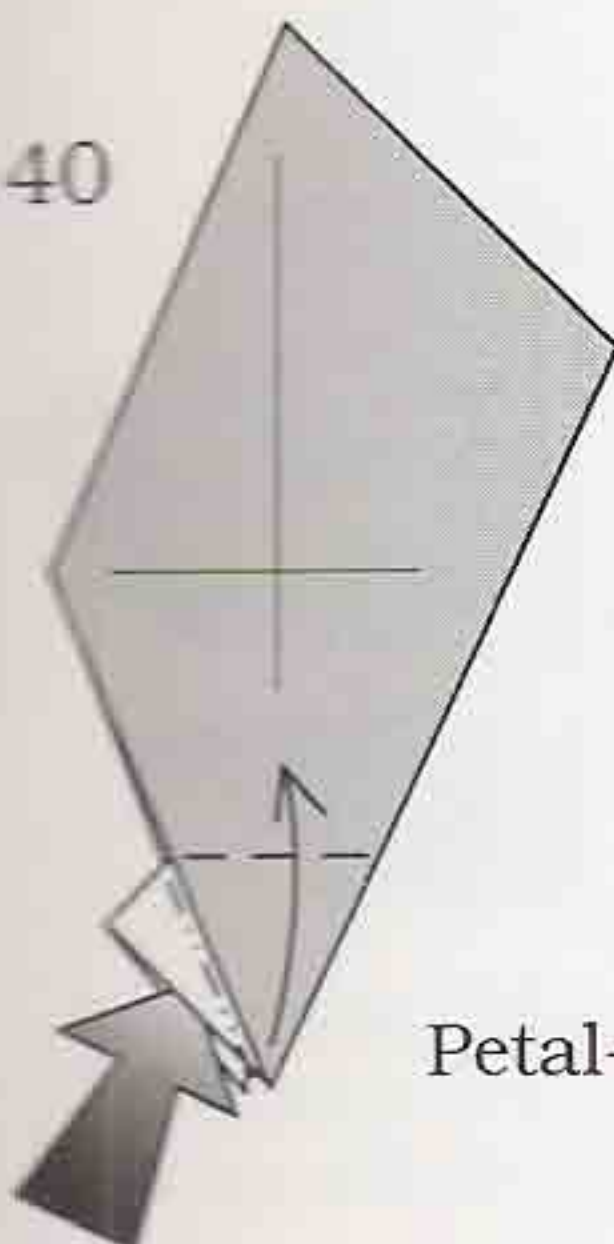

Petal-fold.

41

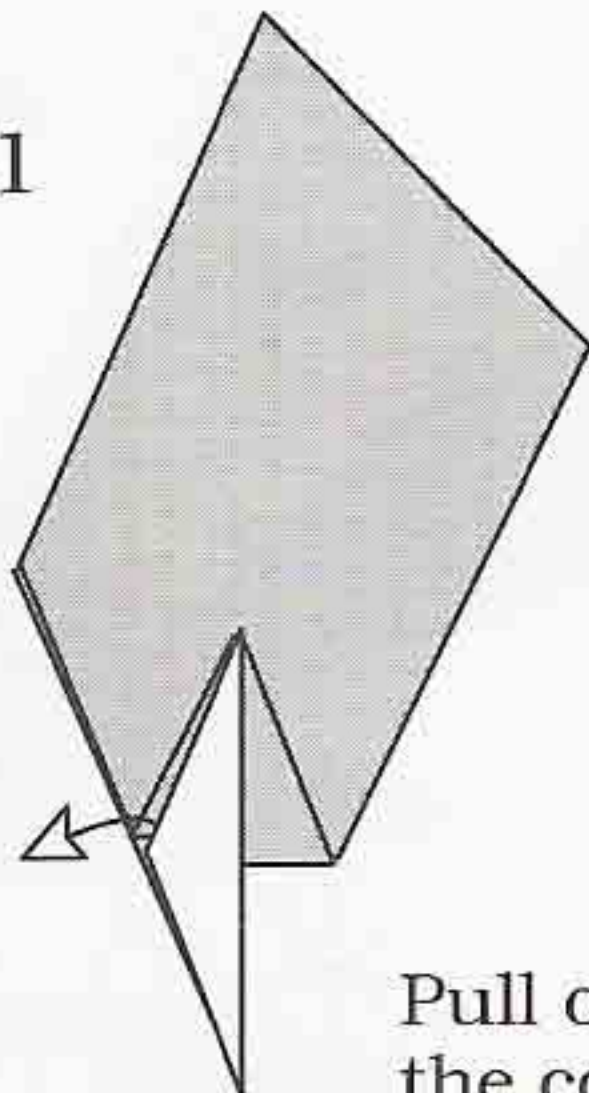

Pull out the corner.

42

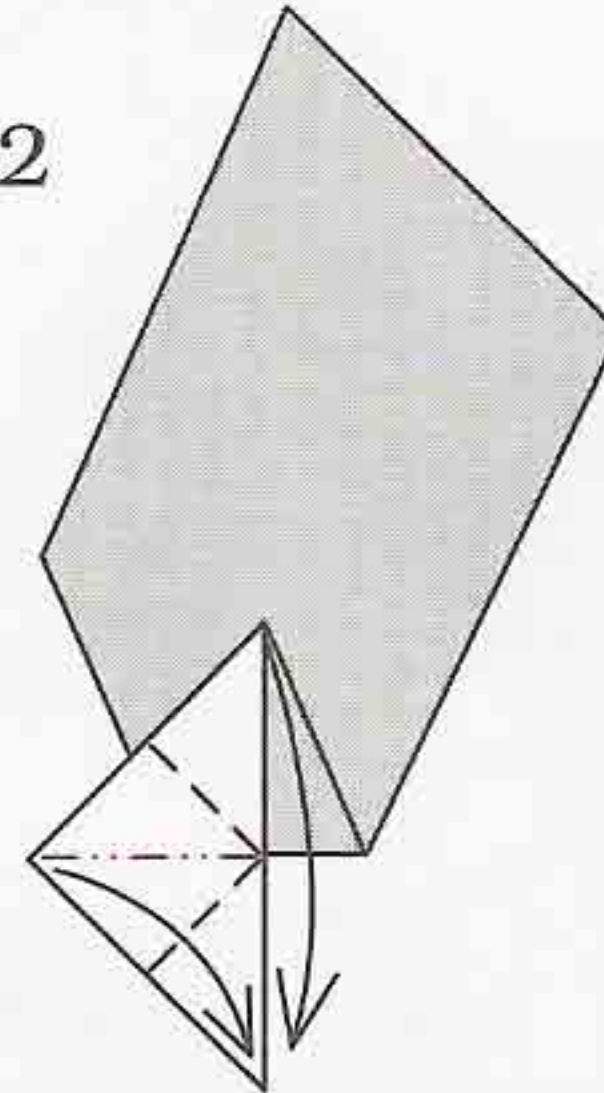

43

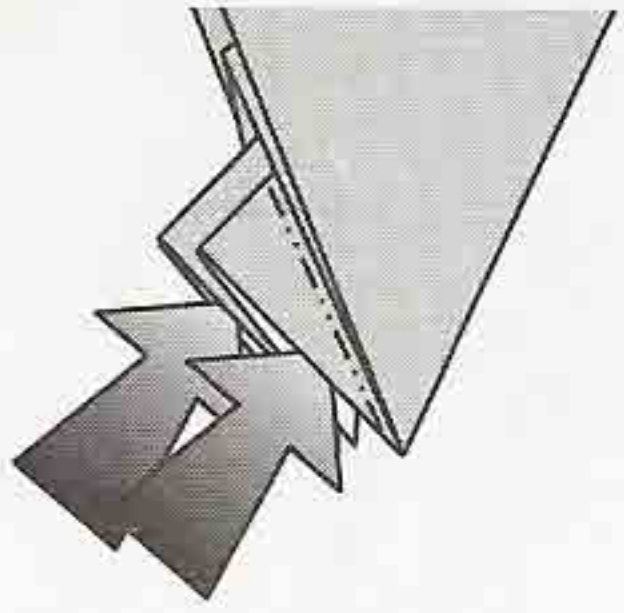

Reverse folds.

44

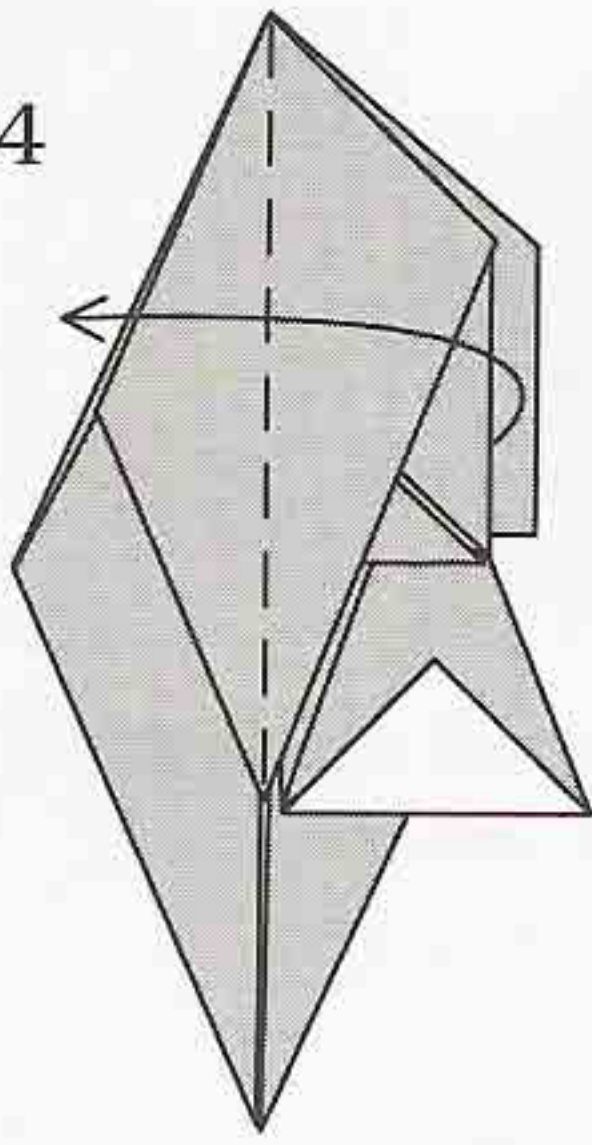

45

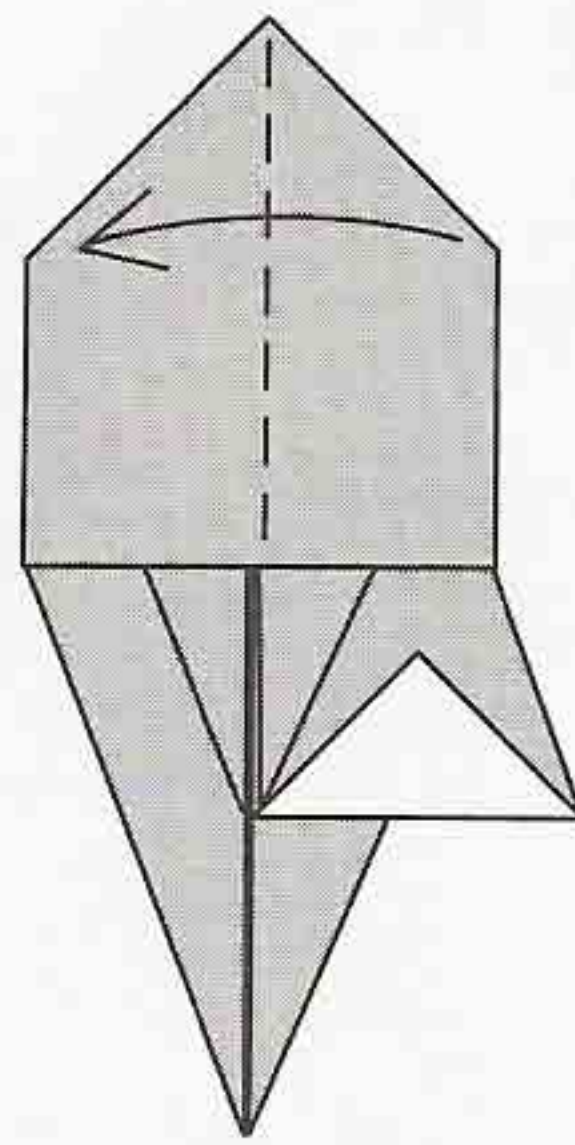

46

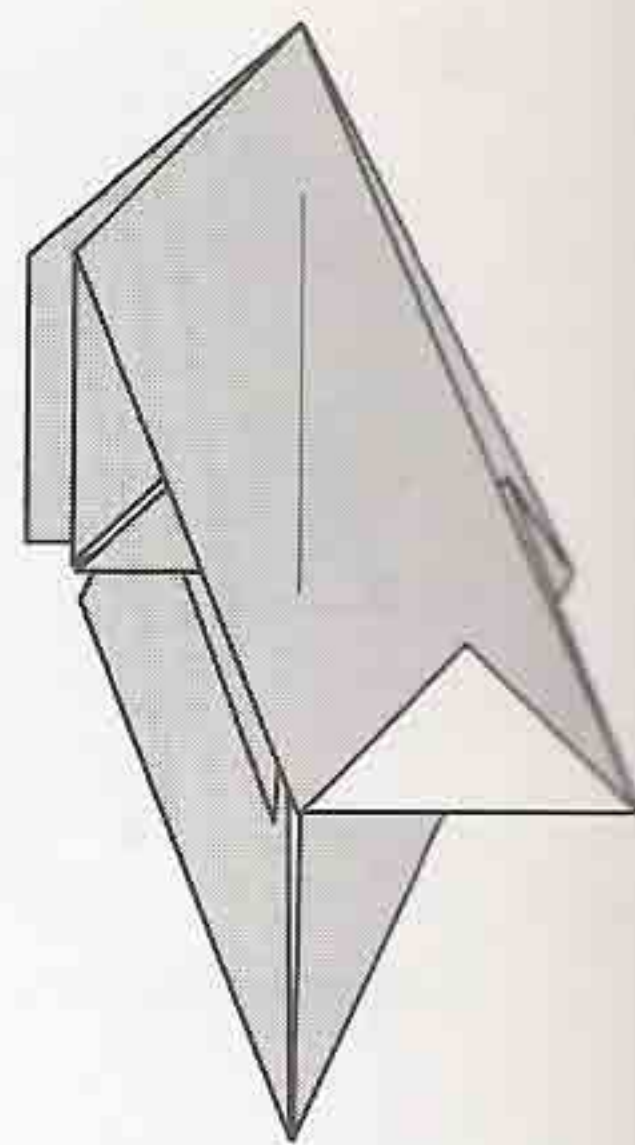

Repeat steps 36-44 on the right.

47

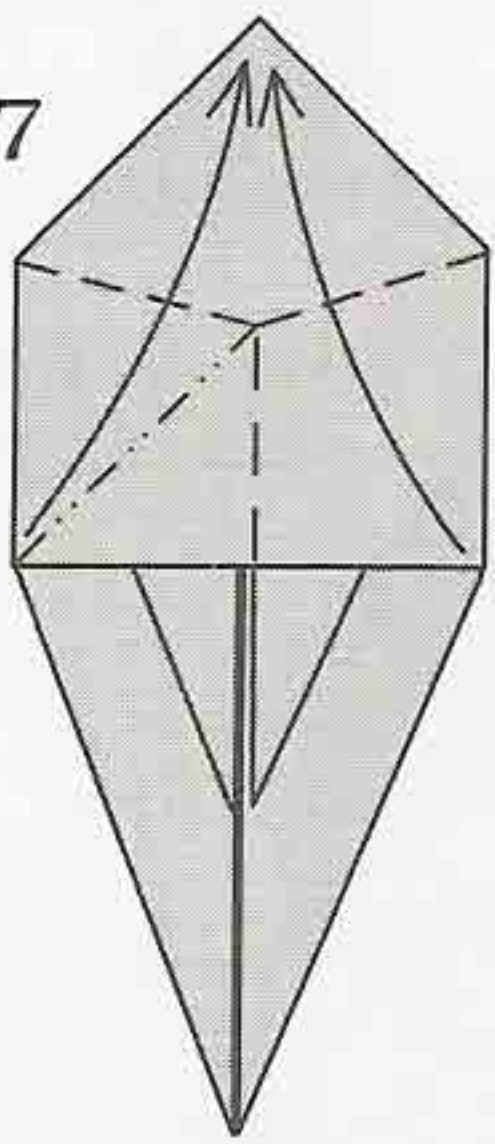

Bring the corners to the top.

48

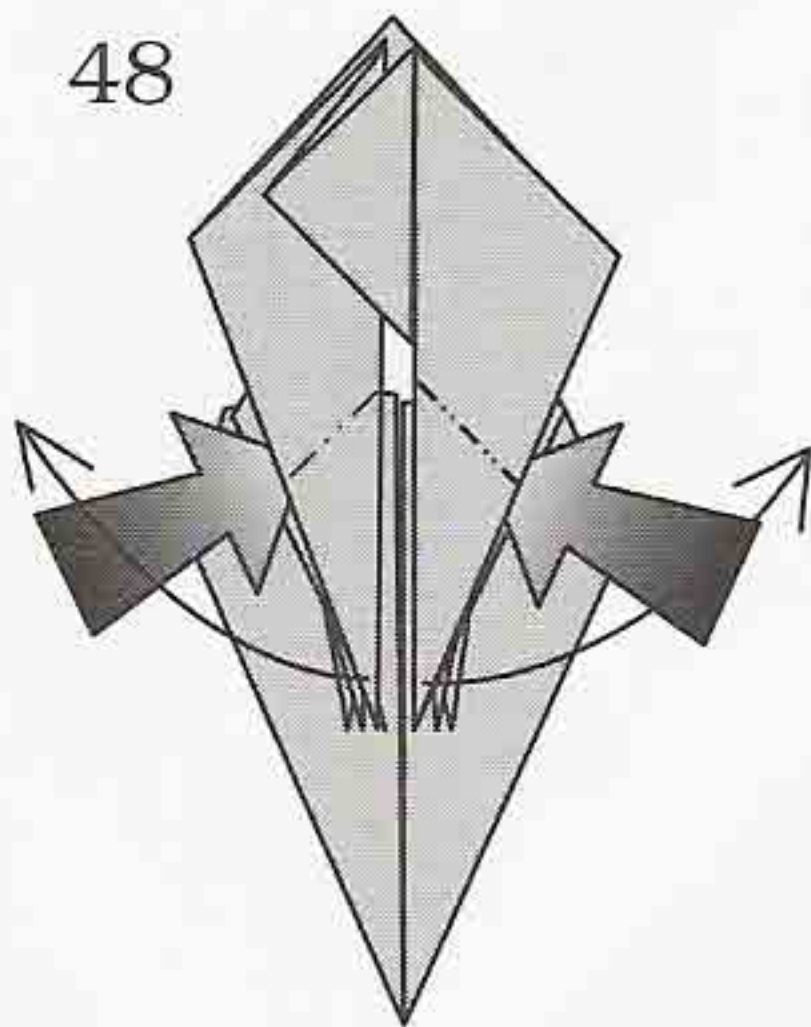

Reverse folds.

49

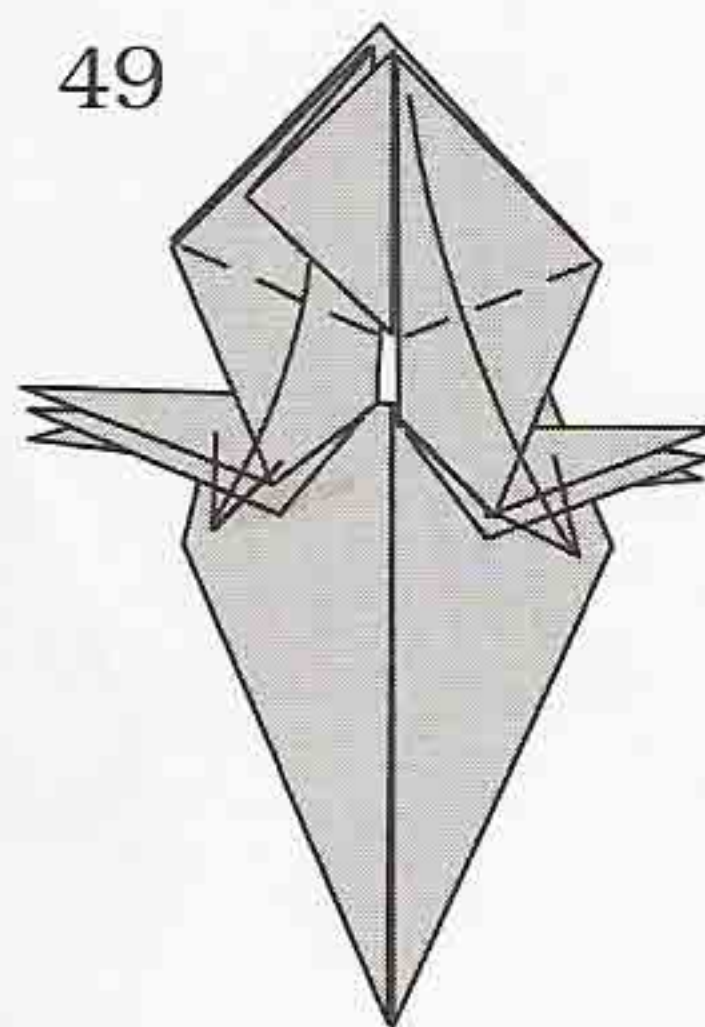

50

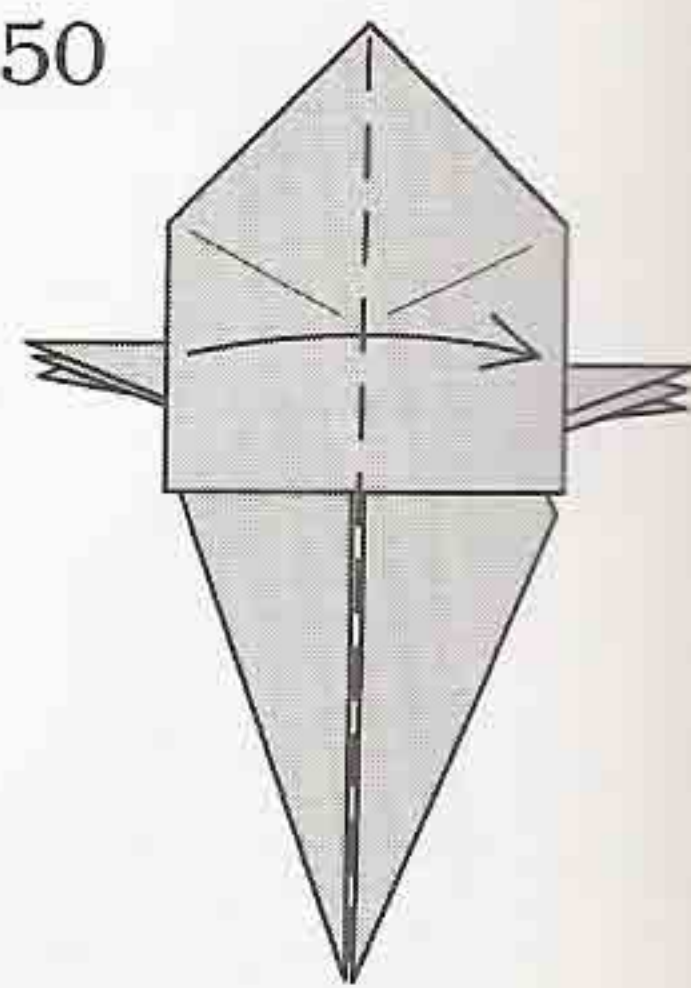

51

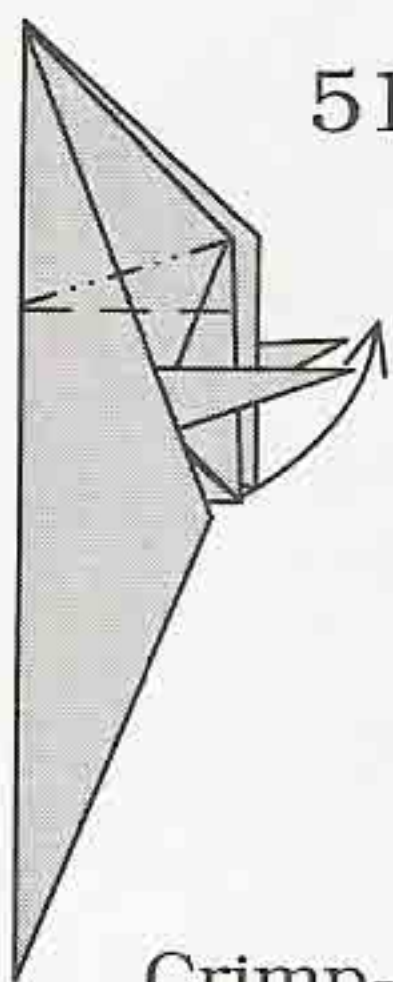

Crimp-fold.

52

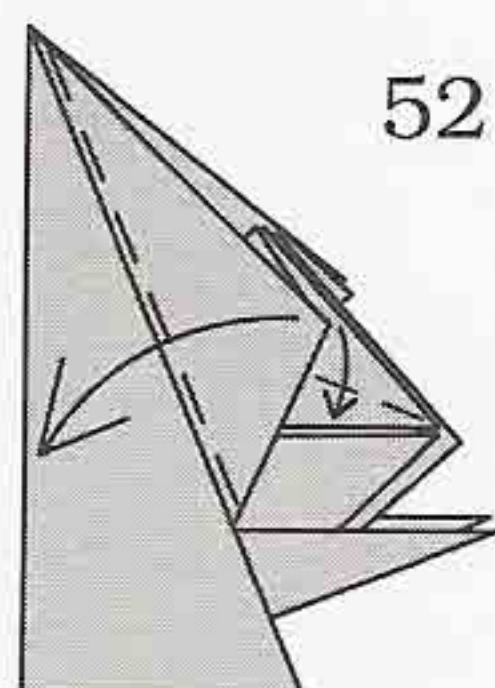

Repeat behind.

53

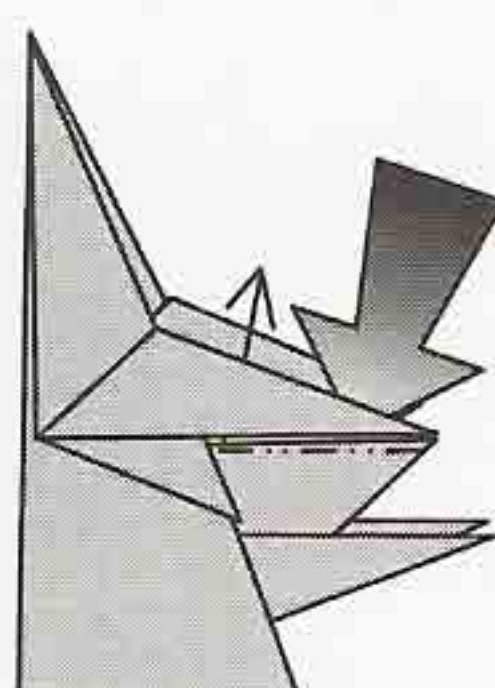

Reverse-fold.

54

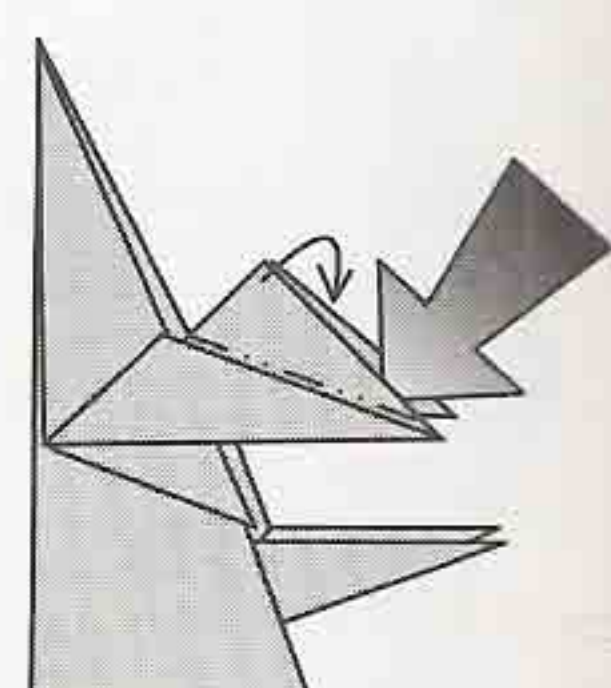

Reverse-fold.

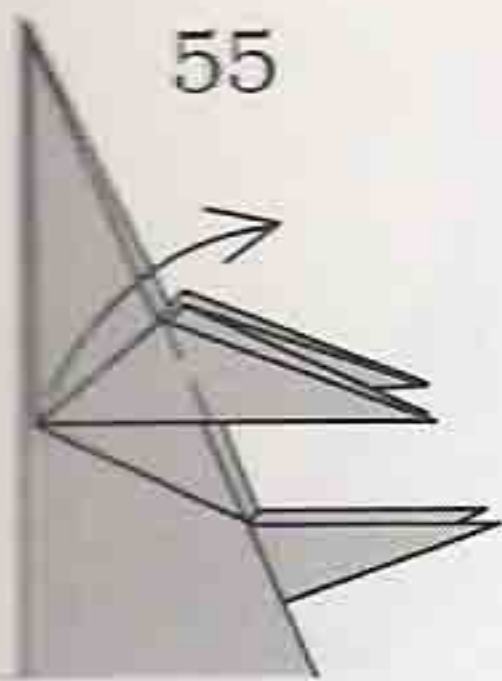

55

Repeat behind.

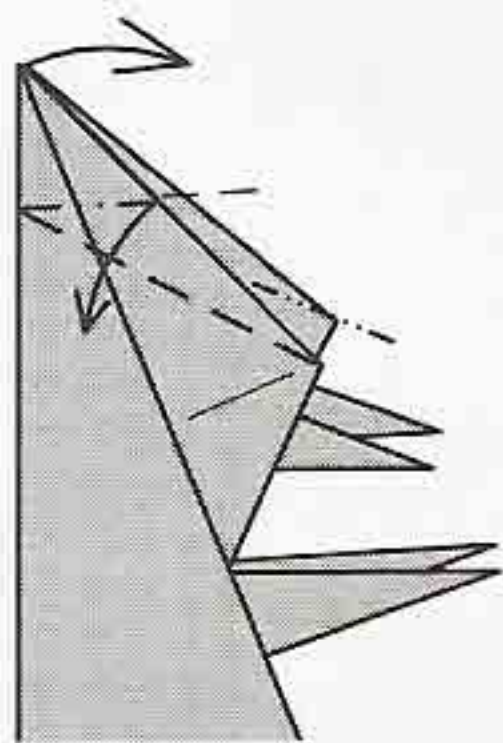

56

Crimp-fold.

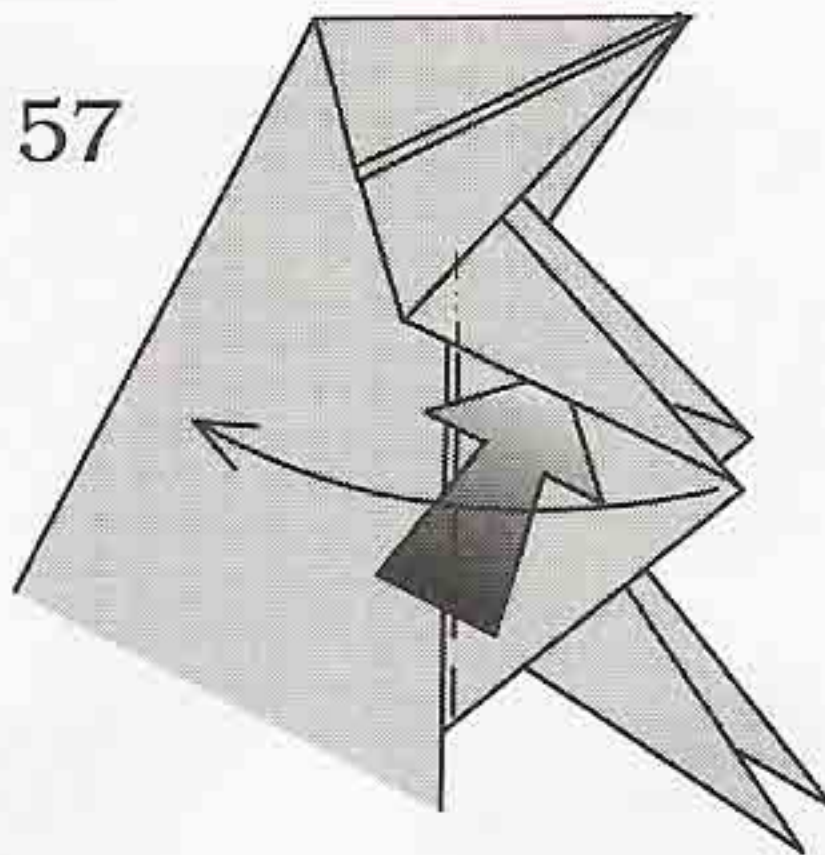

57

Reverse-fold,
repeat behind.

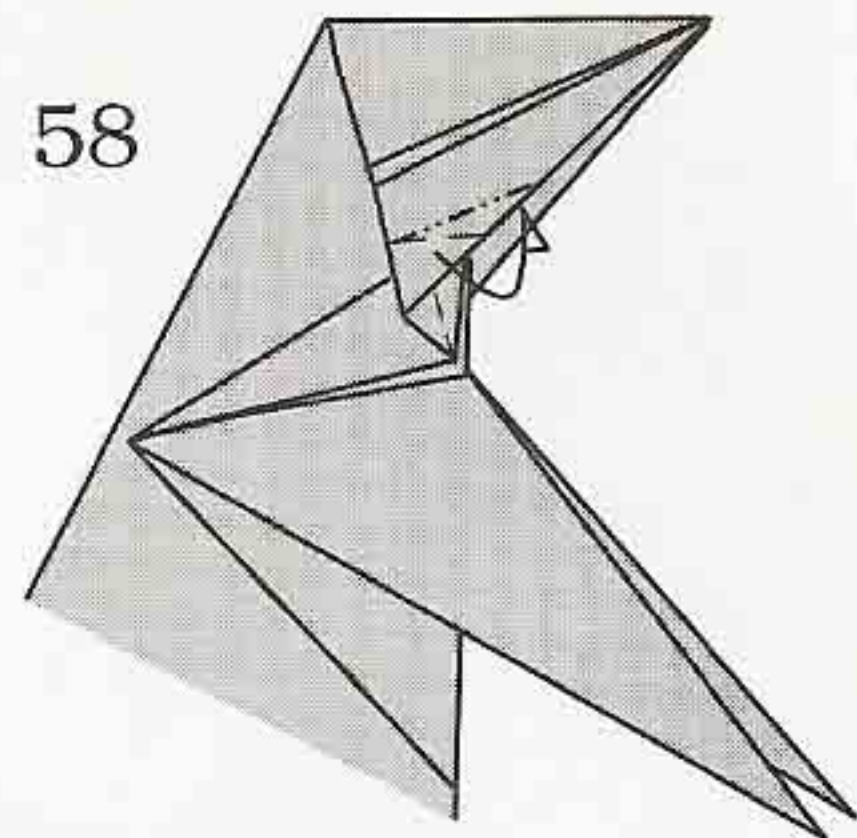

58

Repeat behind.

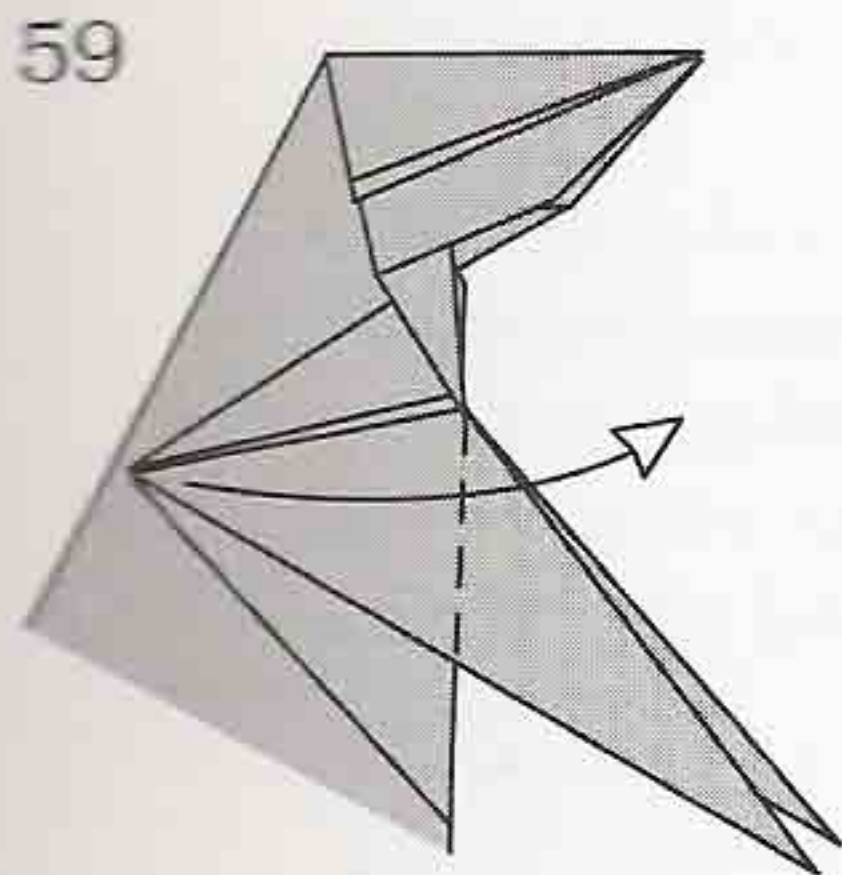

59

Unfold, repeat behind.

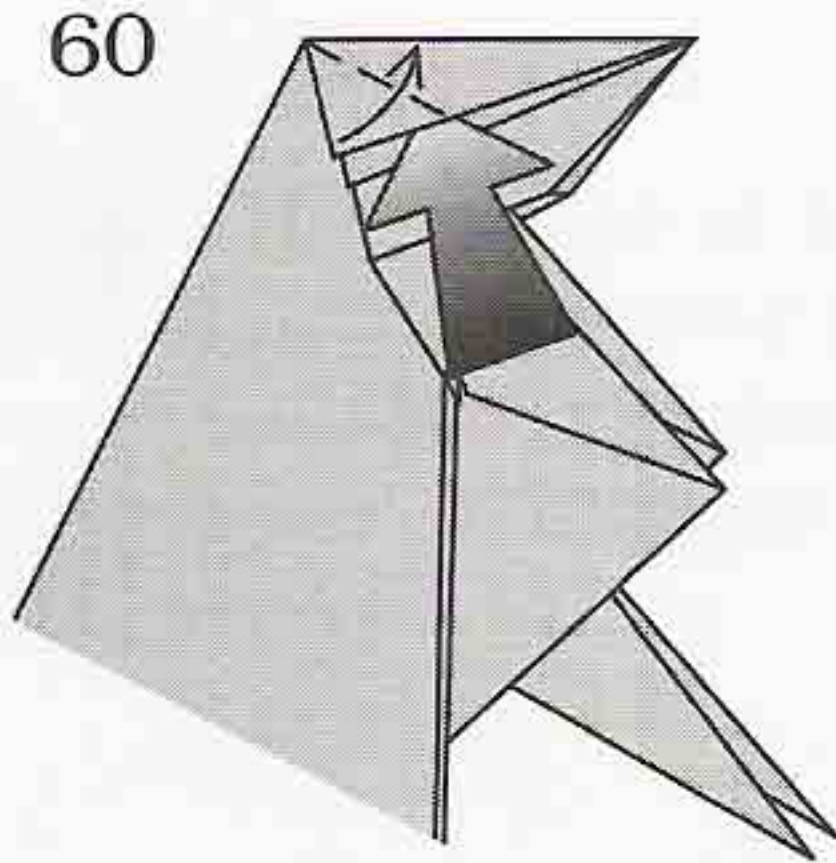

60

Unlock the top layer,
repeat behind.

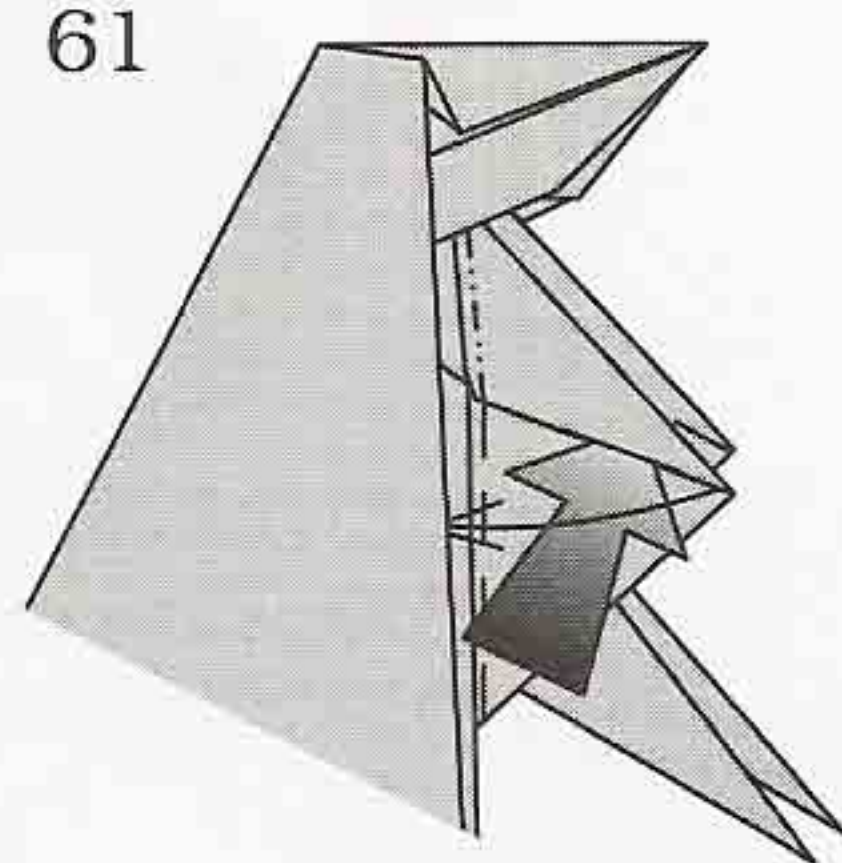

61

Reverse-fold, tuck under the
top layer. Repeat behind.

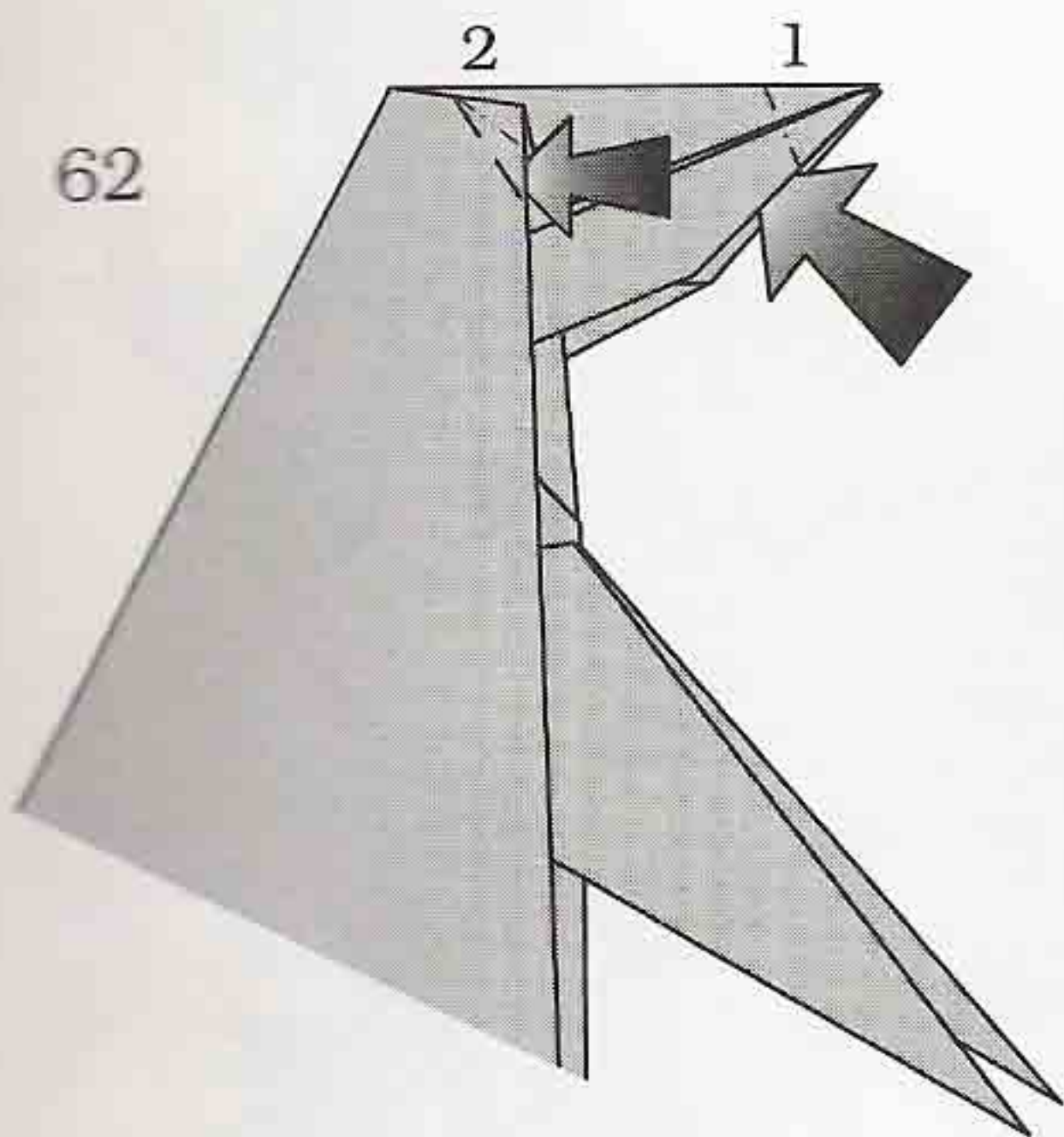

62

1. Reverse-fold the tip.
2. Squash-fold the eye,
repeat behind.

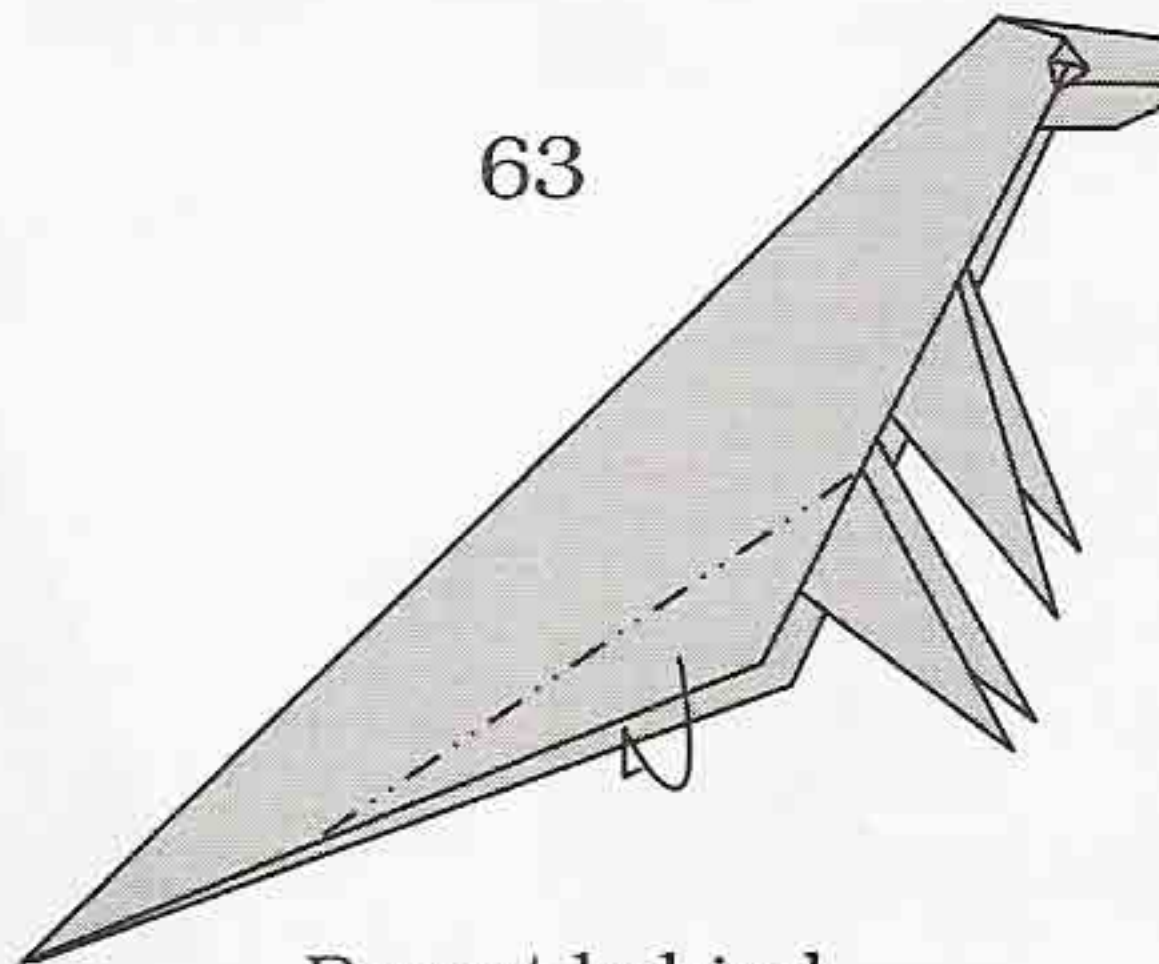

63

Repeat behind.

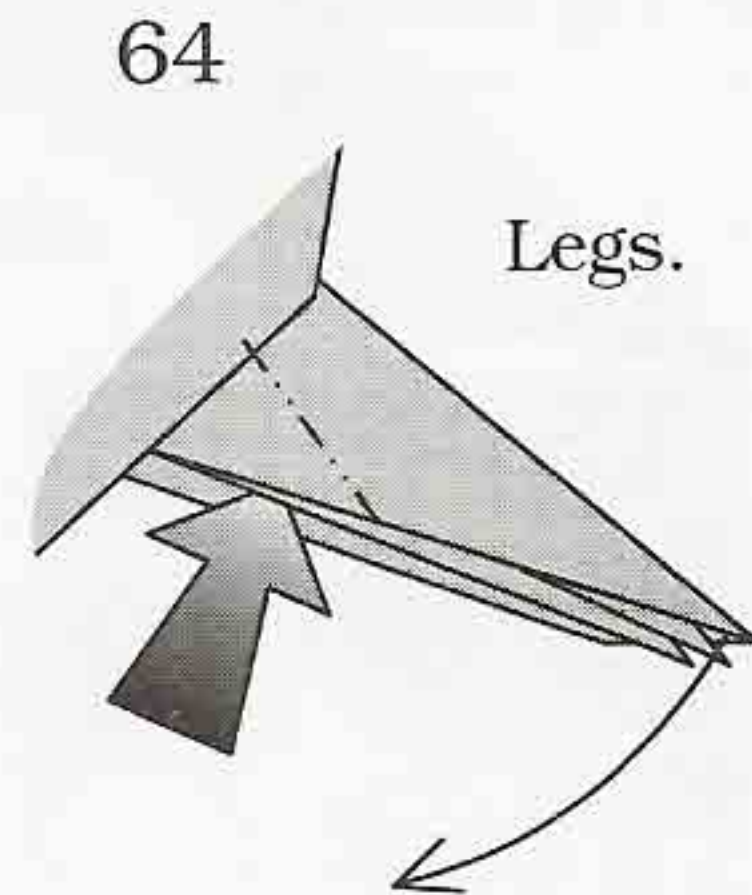

64

Legs.

Reverse-fold,
repeat behind.

65

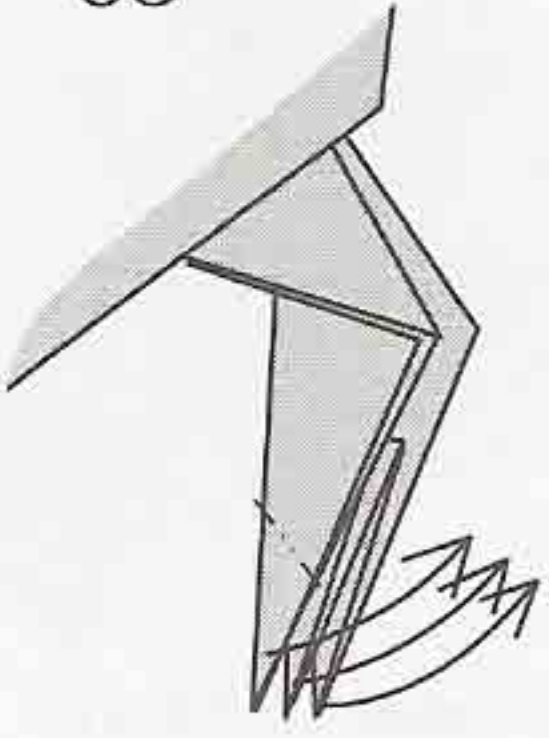

Reverse folds, repeat behind.

66

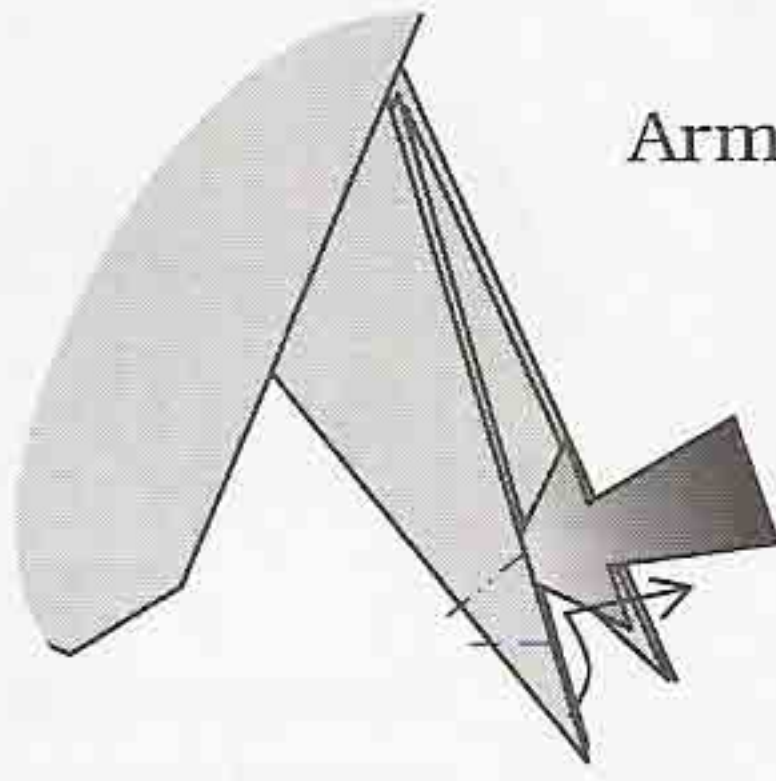

Arms.

Form the thumb with two reverse folds, repeat behind.

67

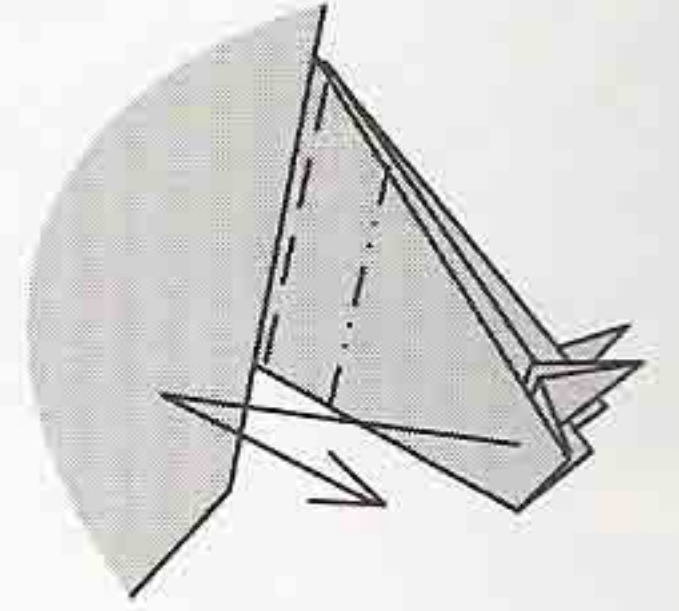

Repeat behind.

68

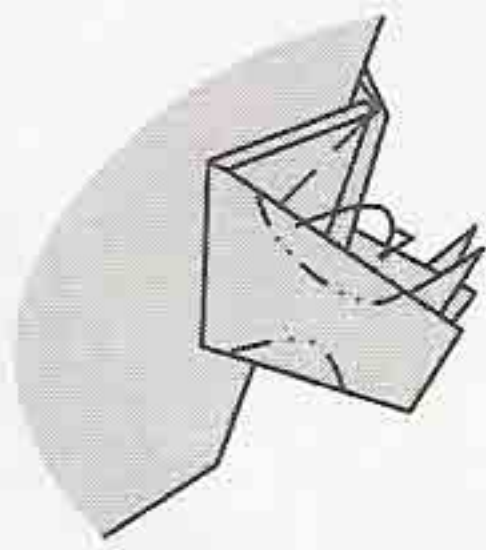

Shape the arms and hands, repeat behind.

69

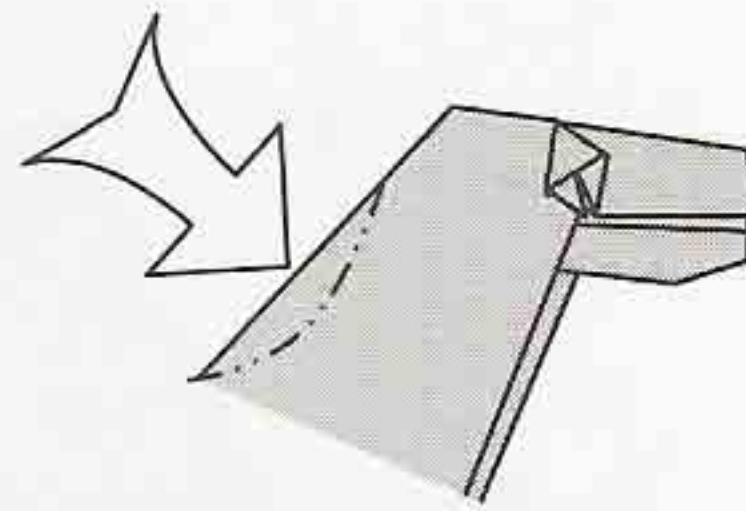

Shape the neck.

70

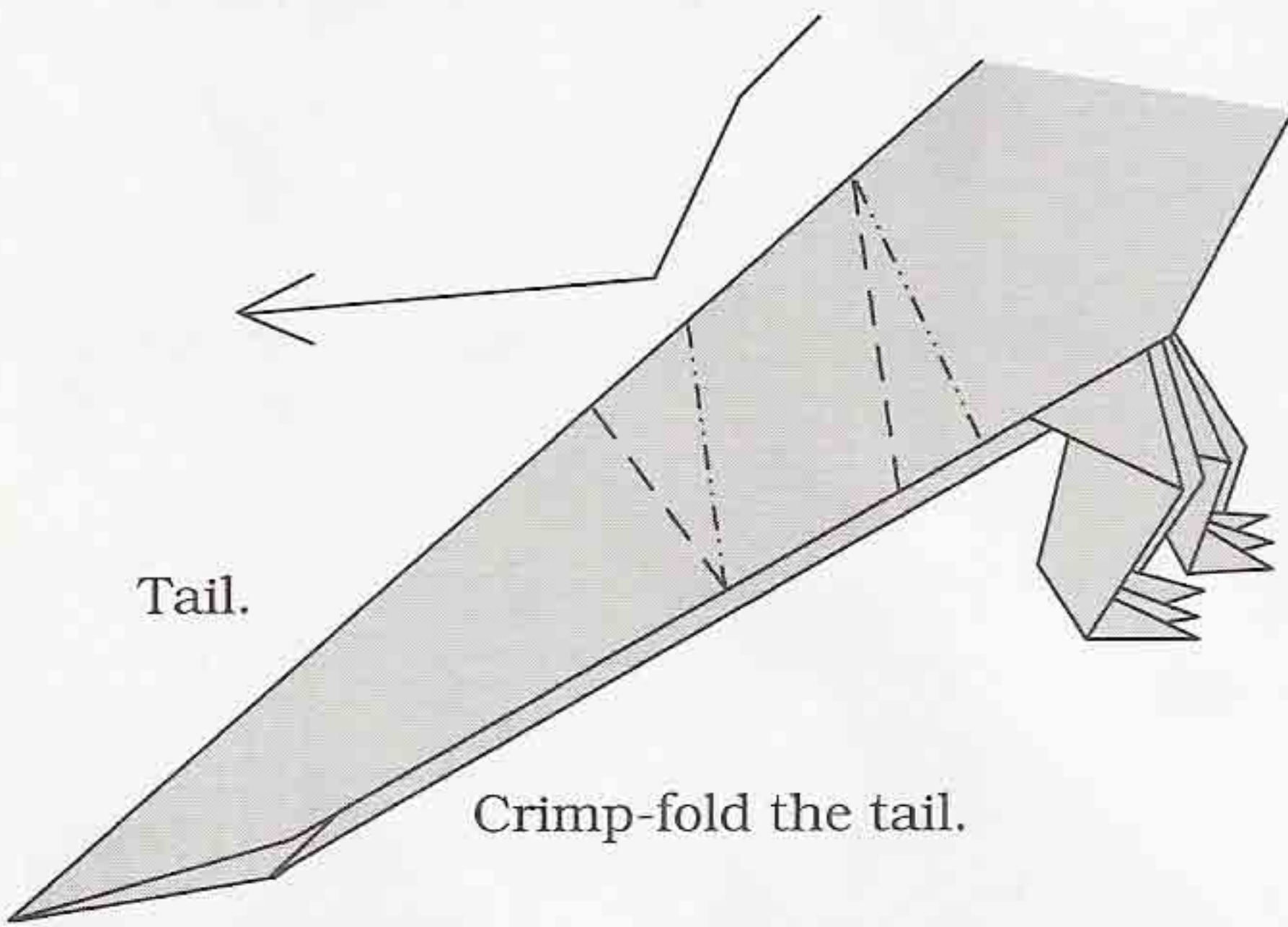

Tail.

Crimp-fold the tail.

71

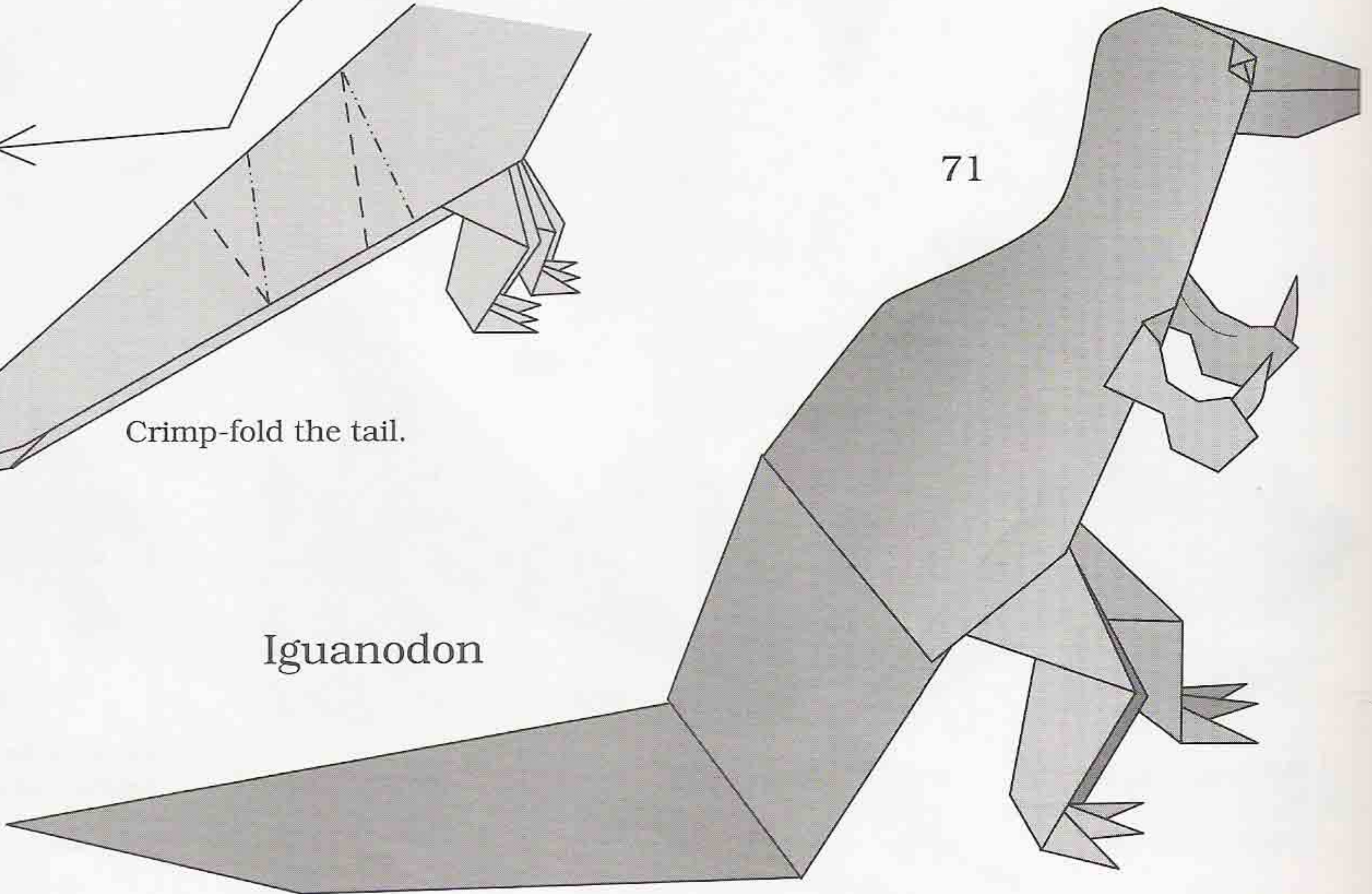

Iguanodon

Kuehneosaurus

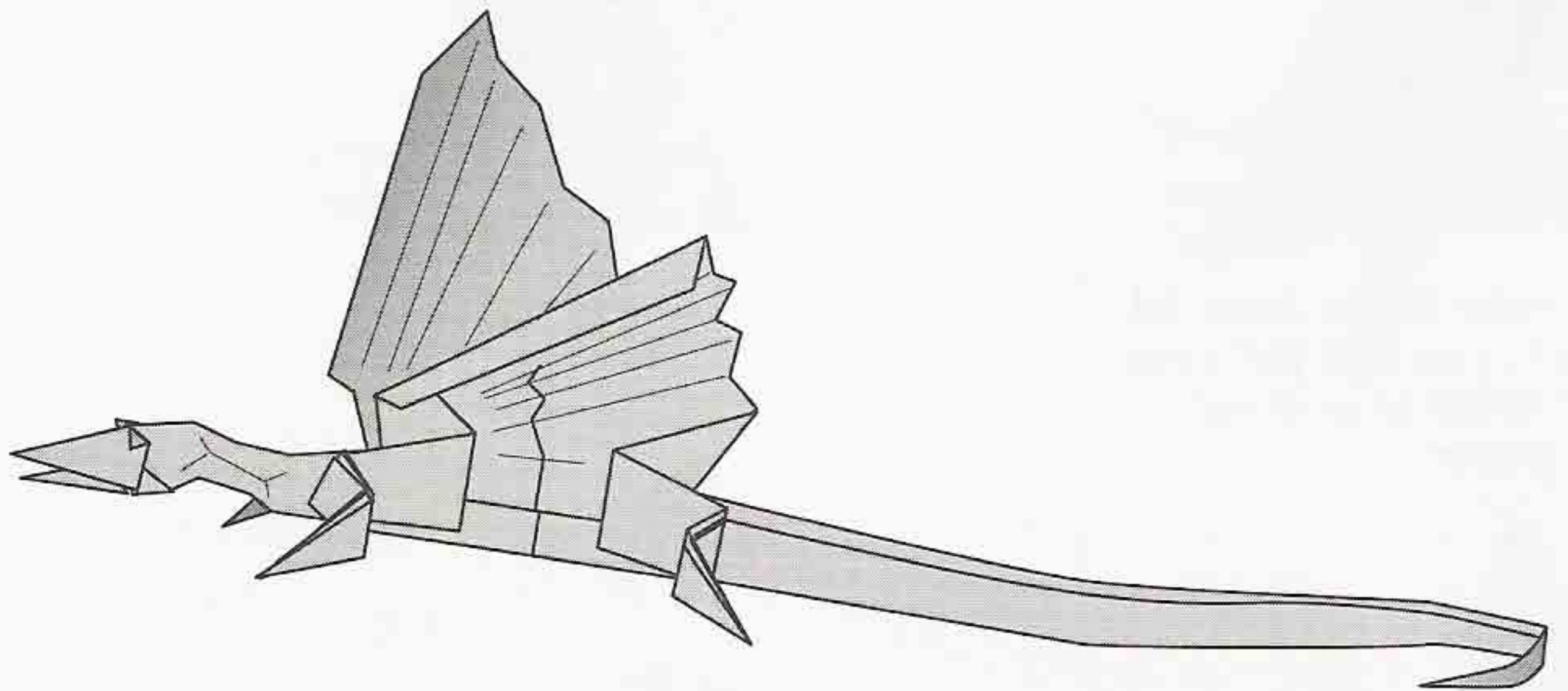

KU-nee-oh-saw-rus

This gliding lizard was 10 to 12 inches long and shared the Triassic period with some of the early dinosaurs. It probably climbed trees, spread its hollow ribs, and glided to earth. The ribs were covered with a thin skin. Insects were its favorite food.

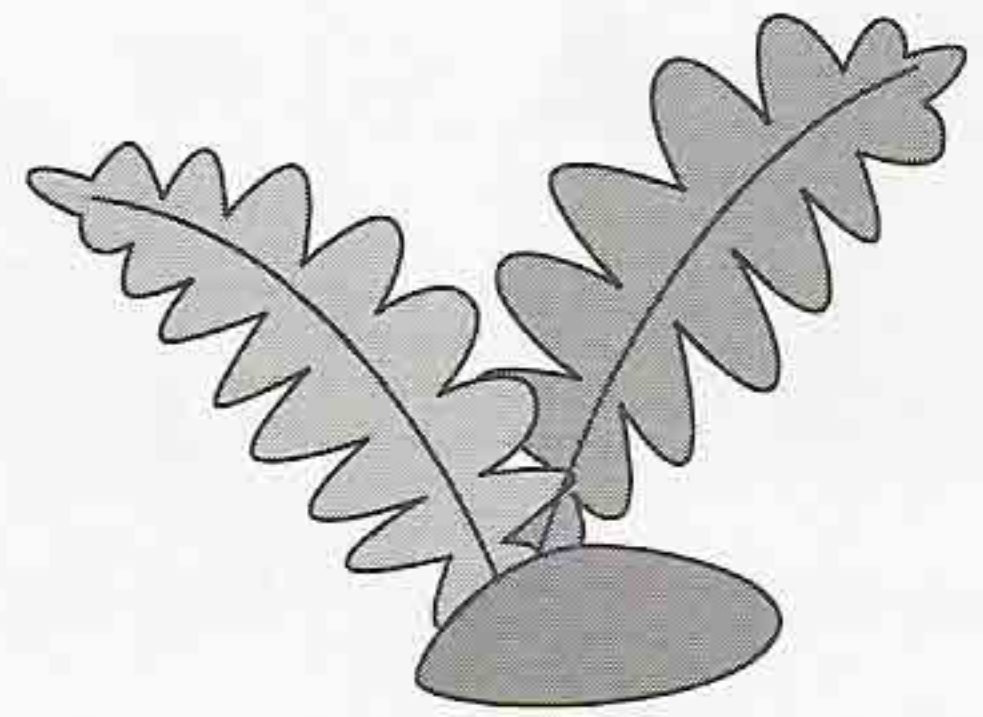

Begin with step 12 of the Struthiomimus (page 25).

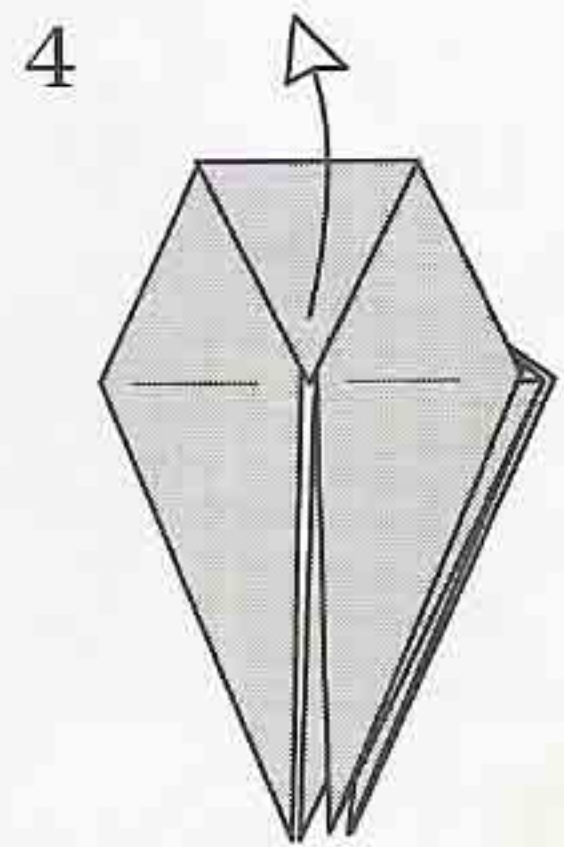
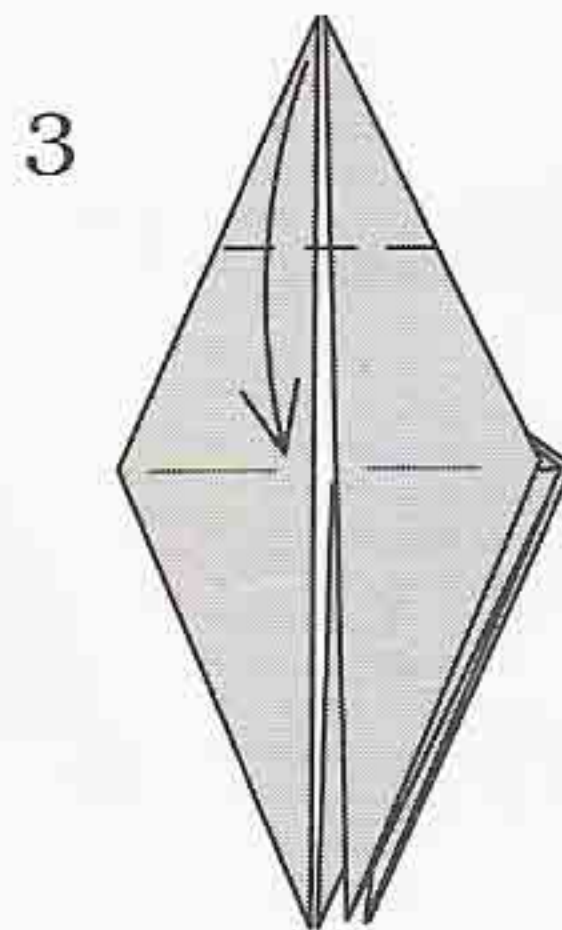
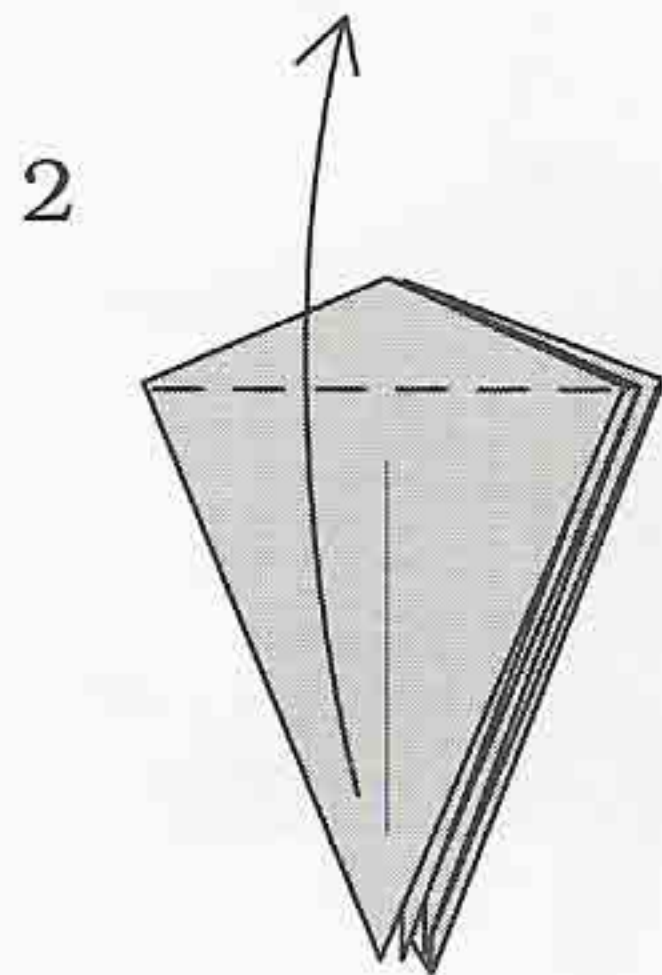
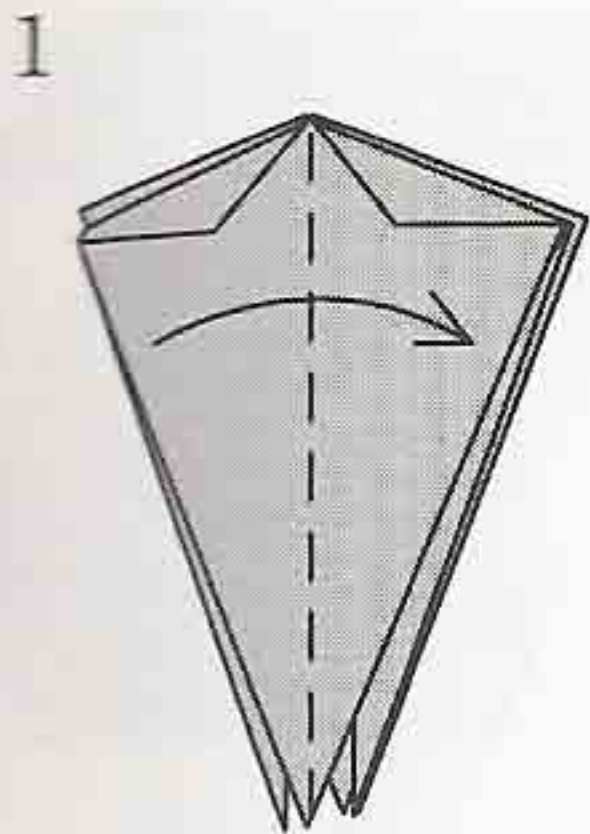

Unfold.

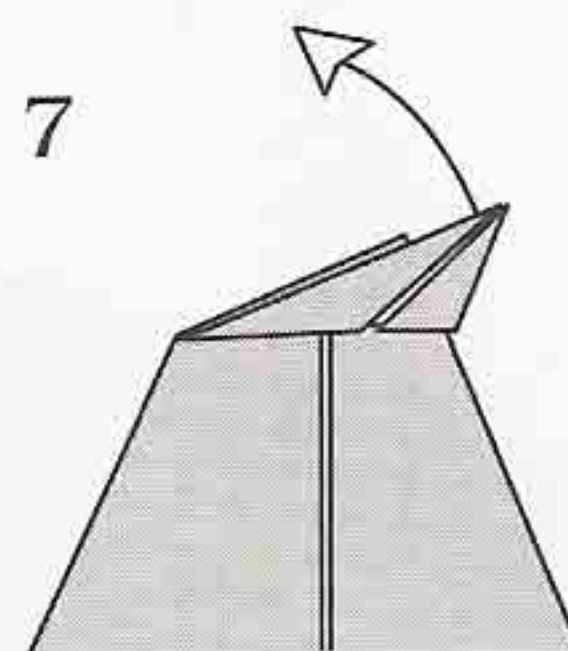
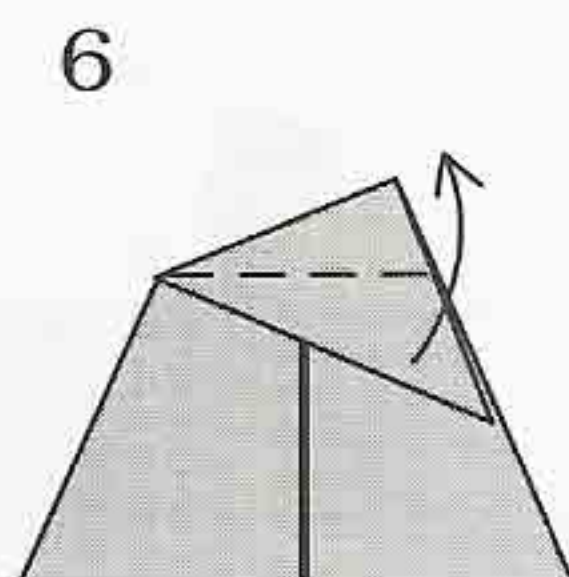
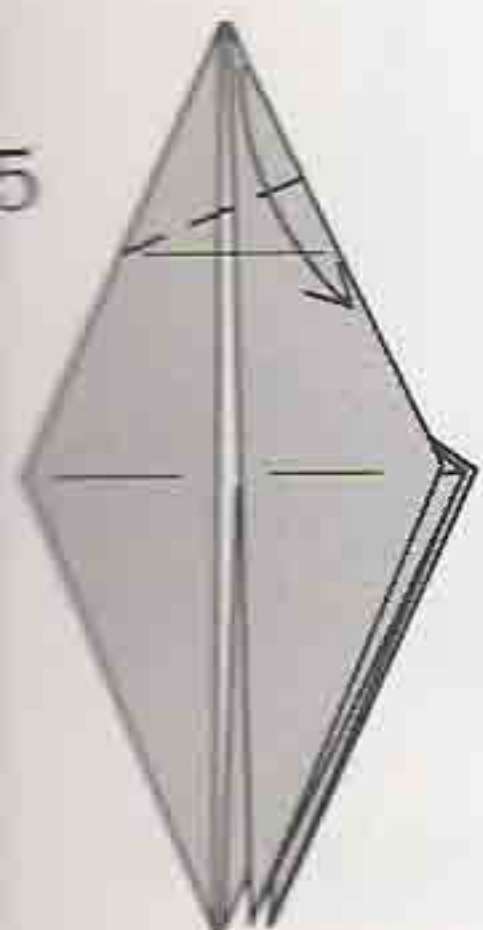

Unfold.

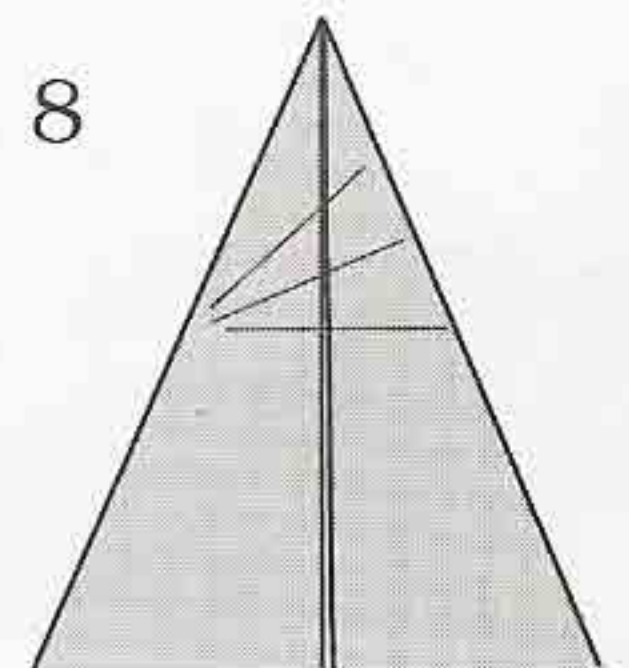

Repeat steps 5-7 in the opposite direction.

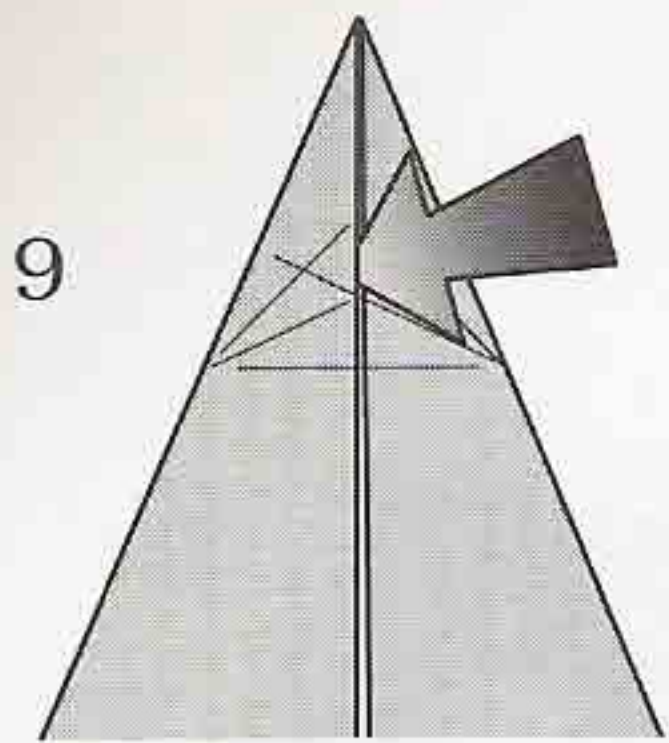

Place your finger here. In step 11, you will put your finger there to pull out some paper.

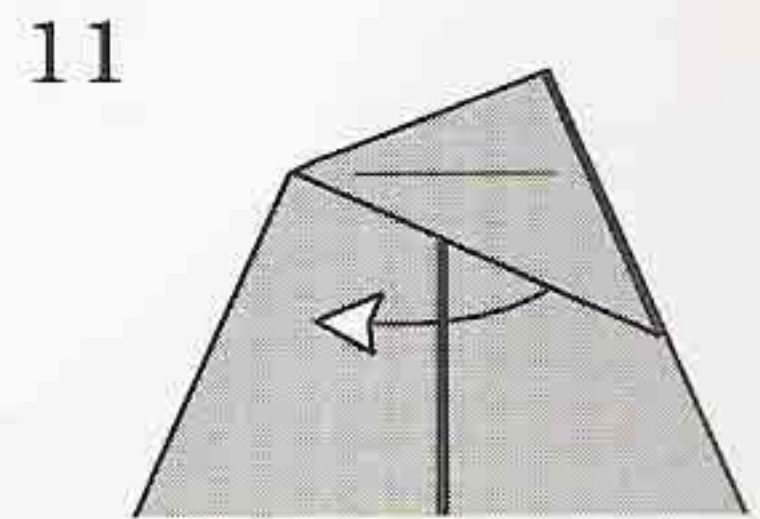
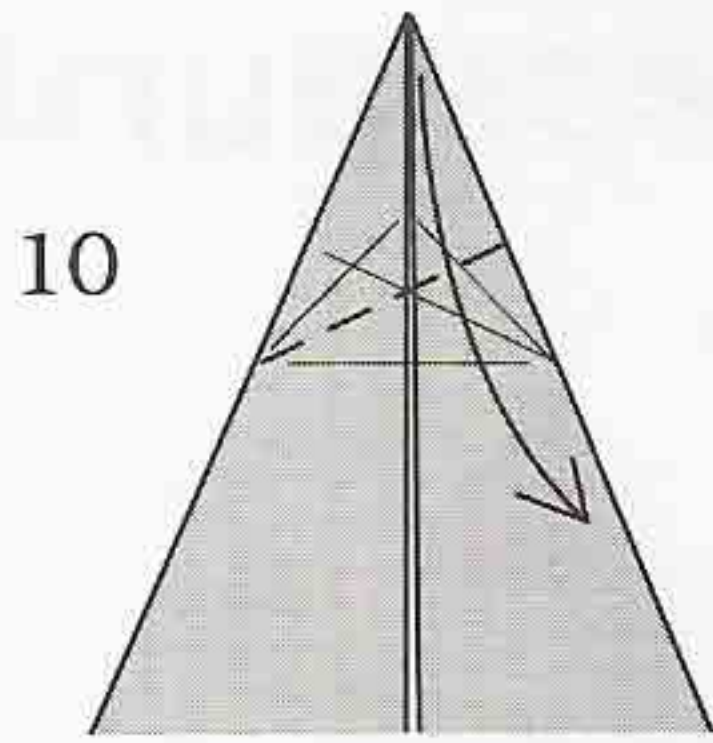

To pull out some paper, place your finger as shown in step 9.

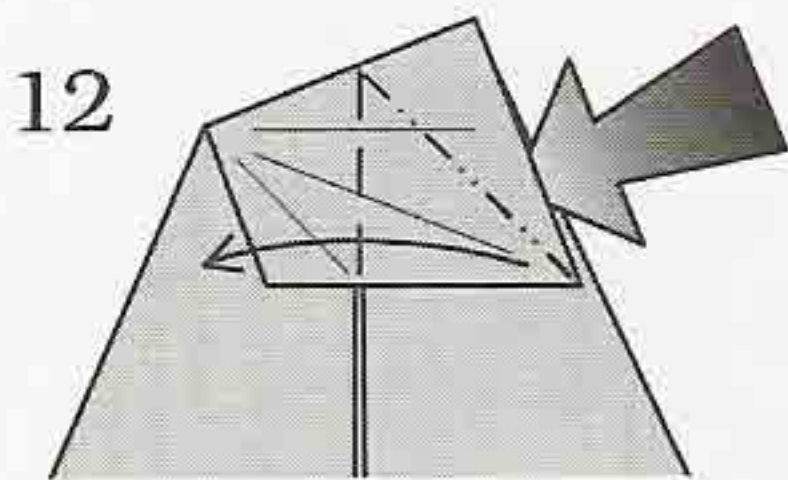

Squash-fold.

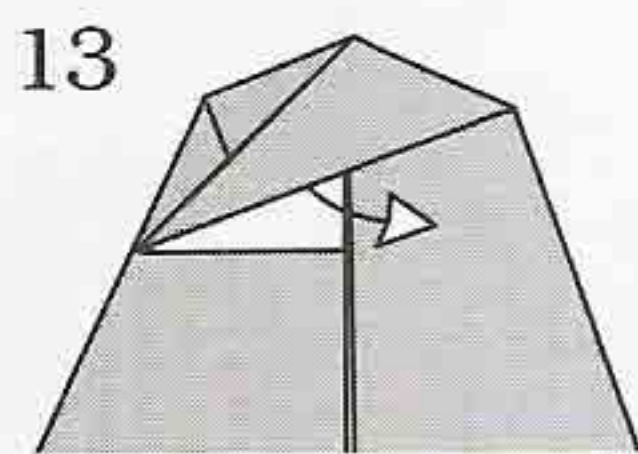

Pull out some paper.

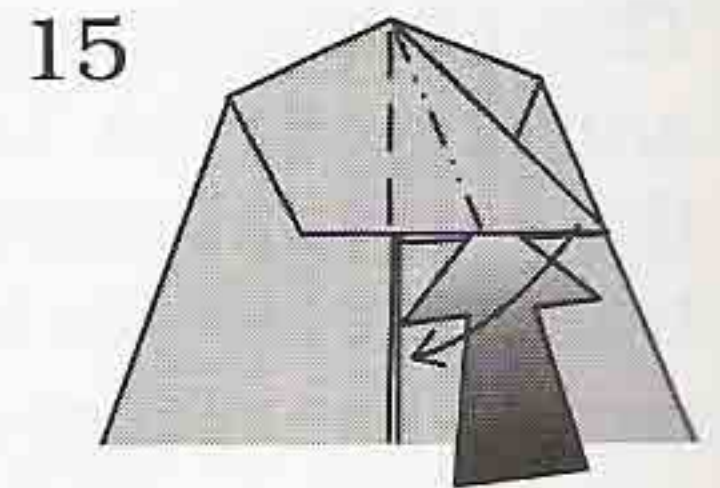
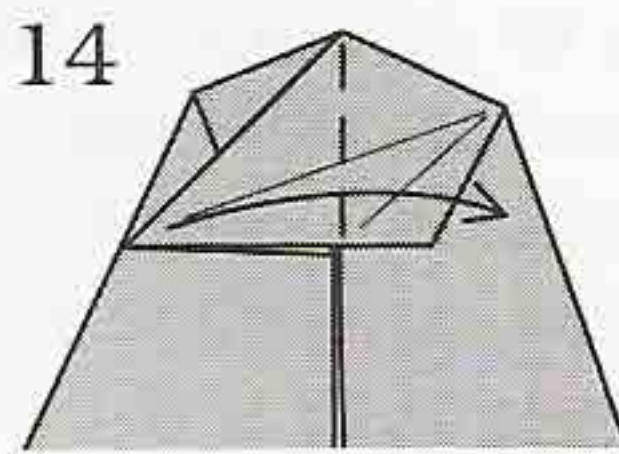

Squash-fold.

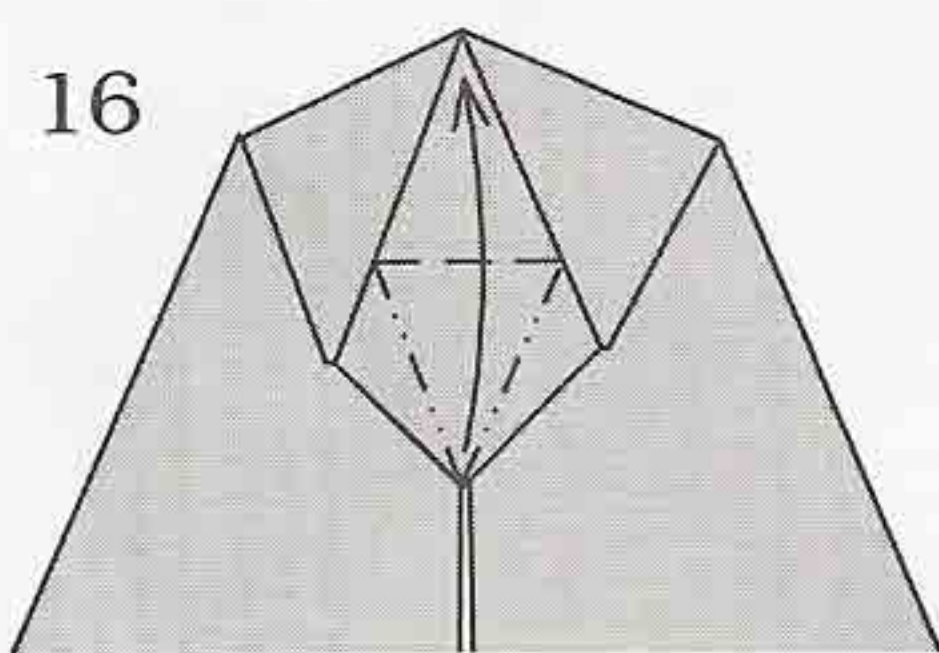

Petal-fold.

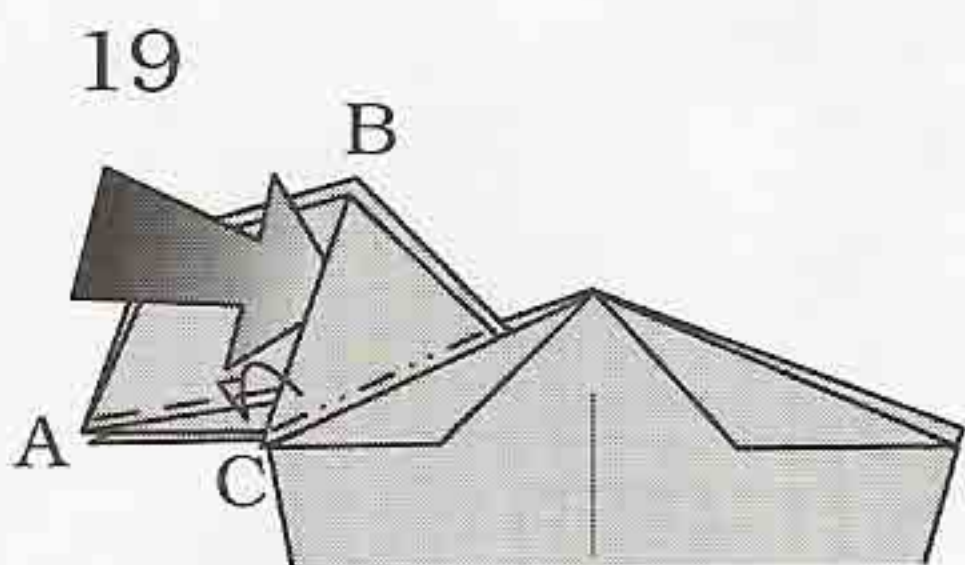
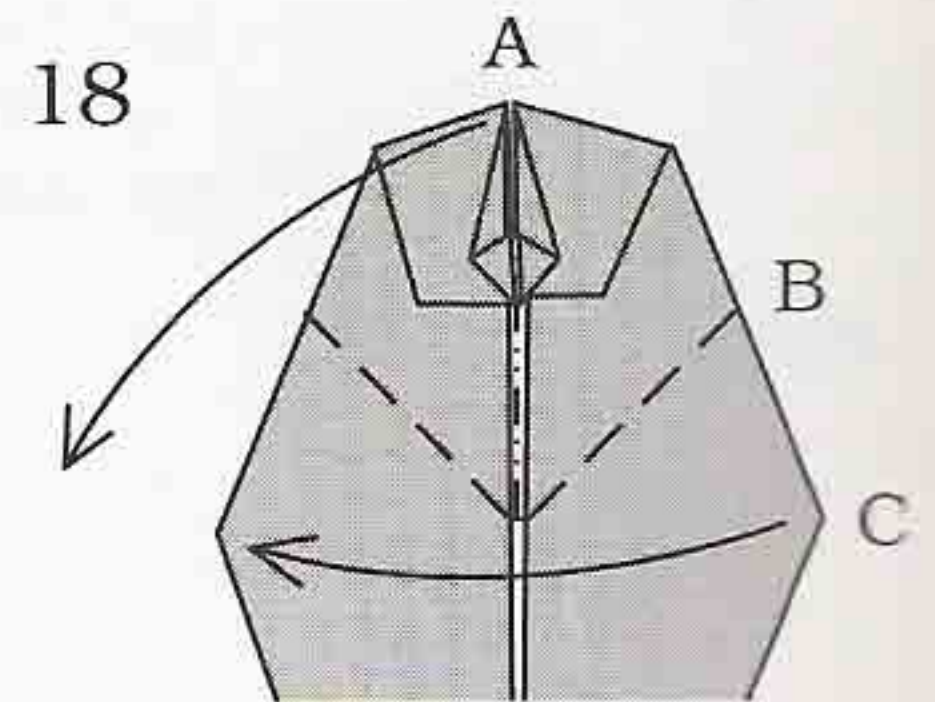
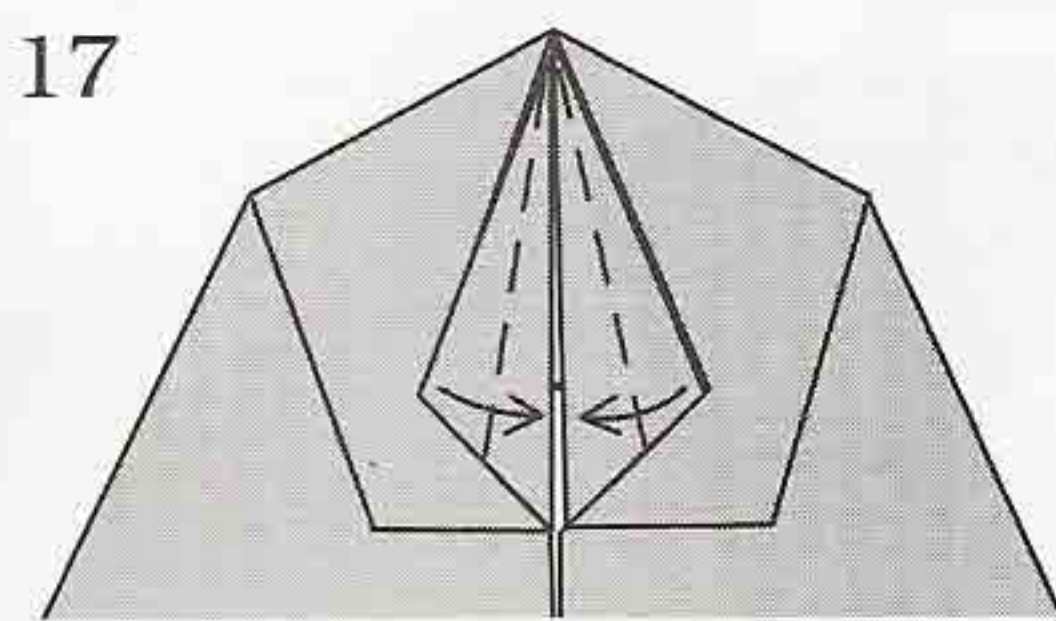

Reverse-fold repeat behind.

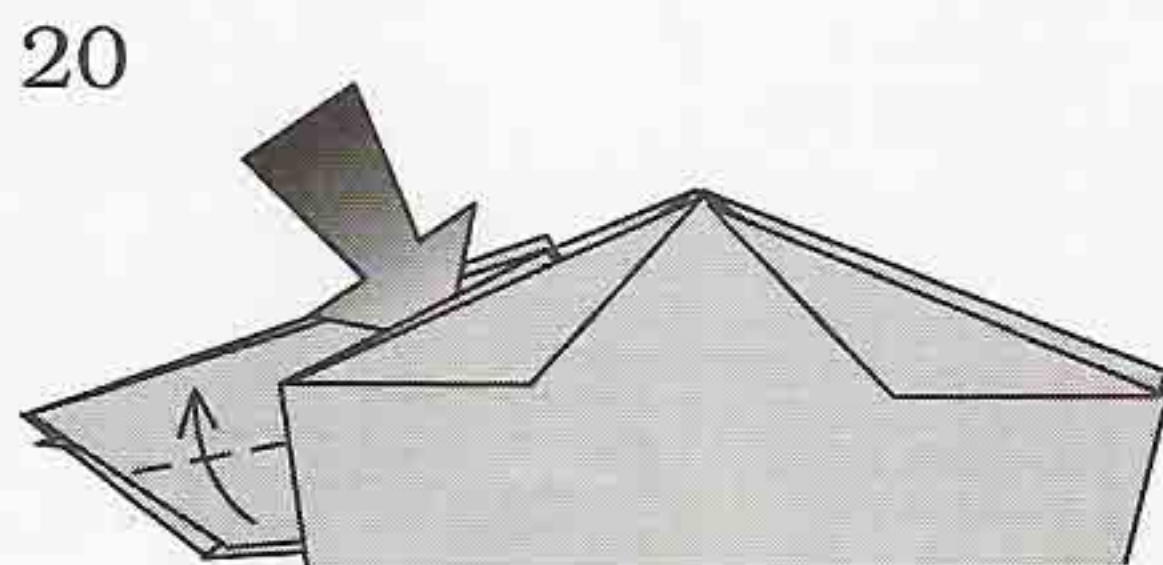

Reverse-fold repeat behind.

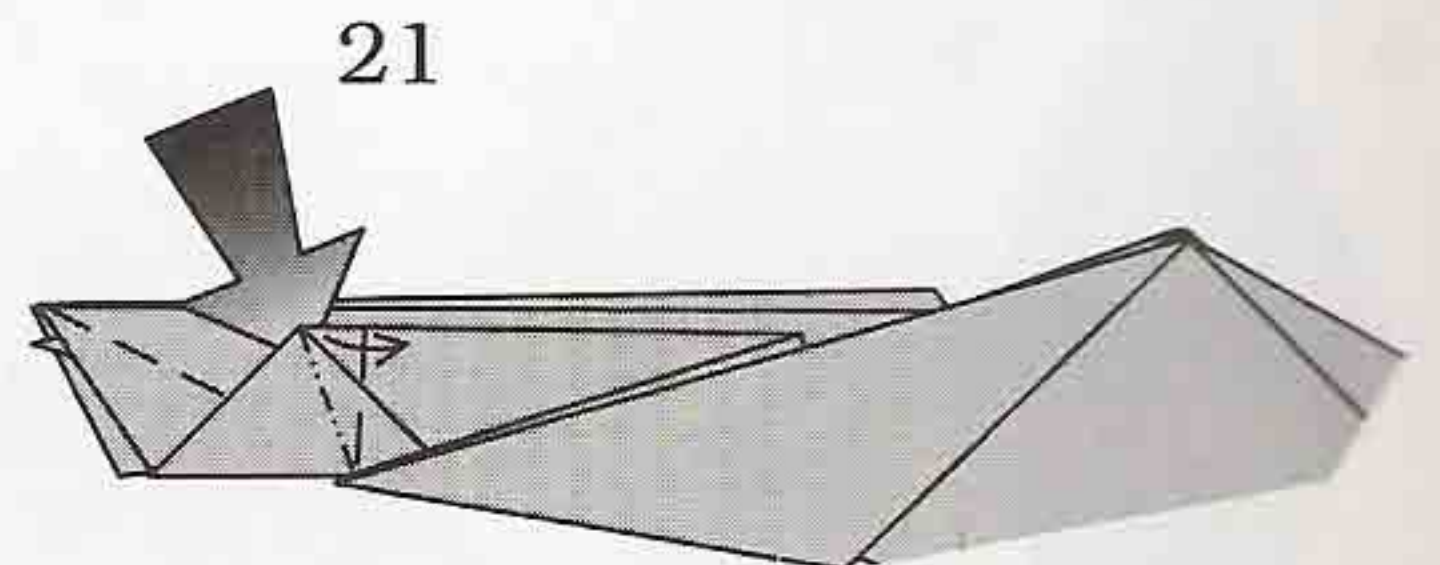

Squash-fold, repeat behind.

22

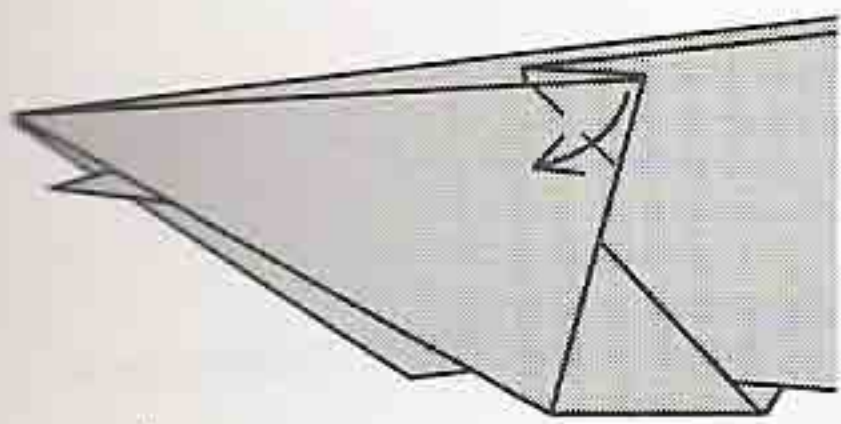

Form the eye, repeat behind.

23

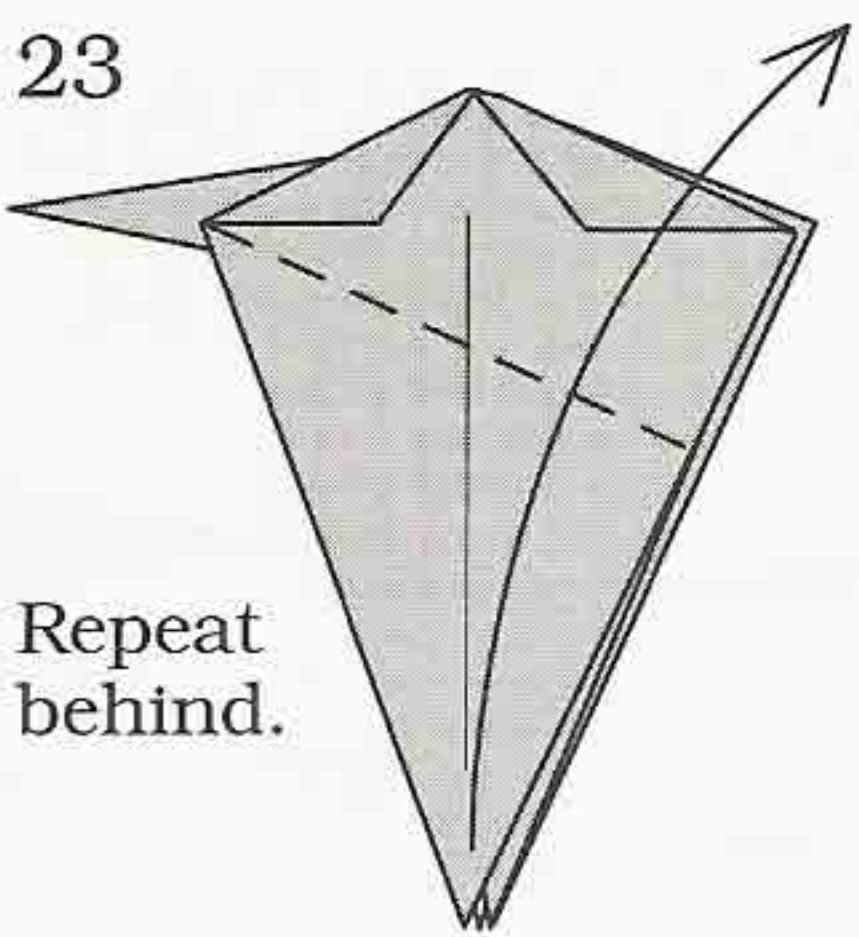

Repeat behind.

24

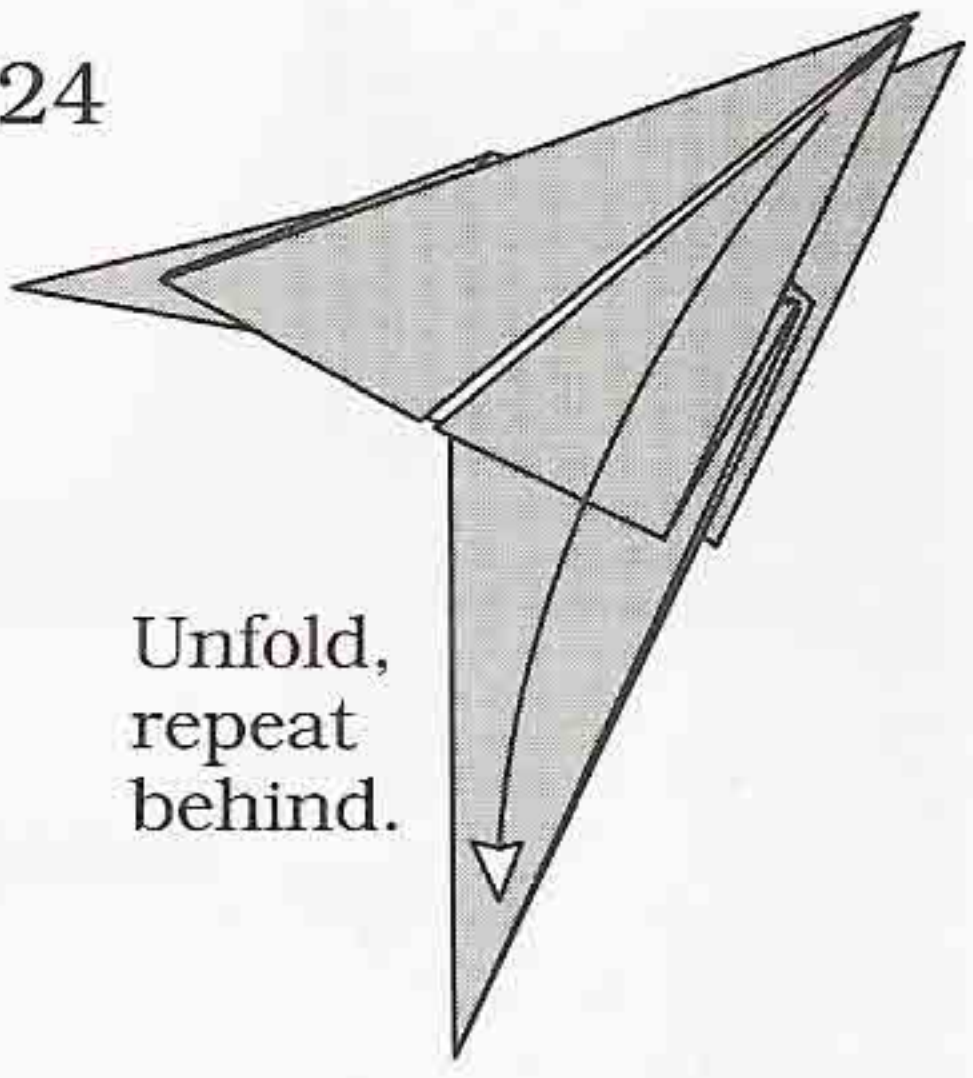

Unfold, repeat behind.

25

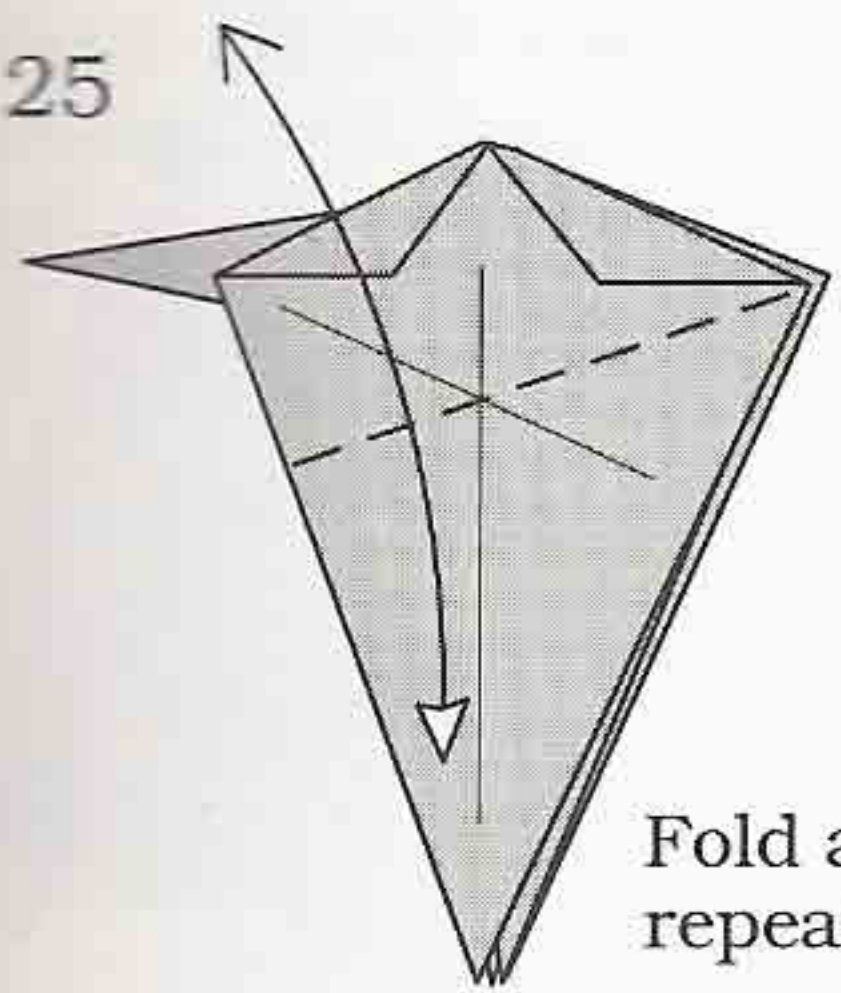

Fold and unfold, repeat behind.

26

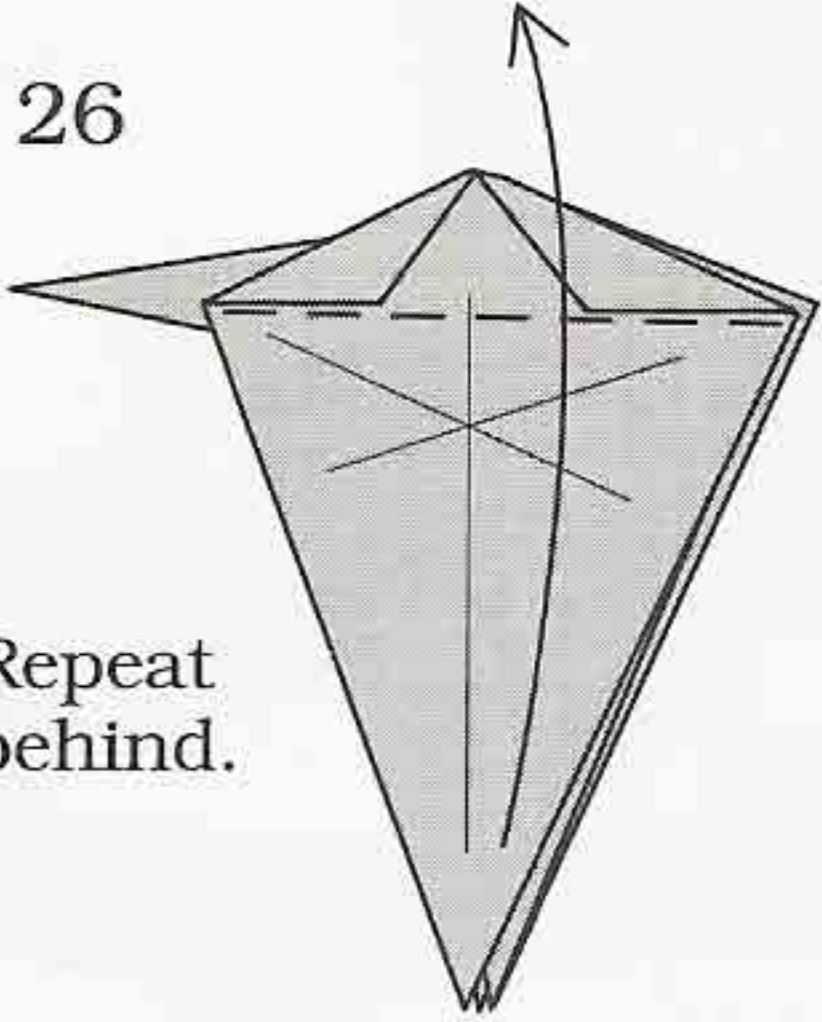

Repeat behind.

27

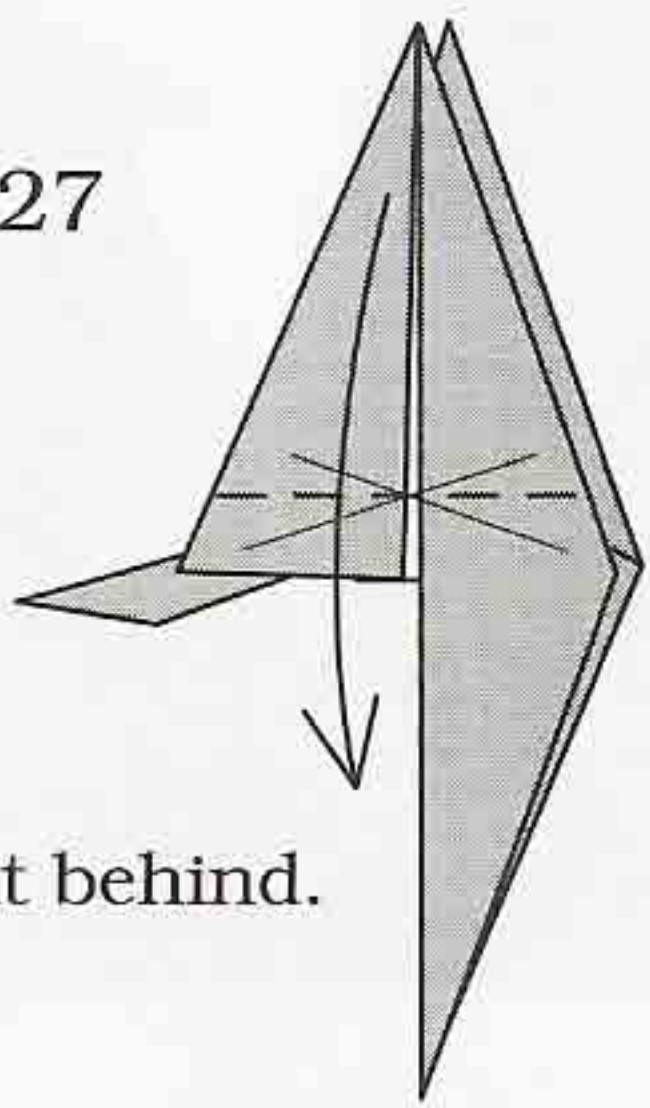

Repeat behind.

28

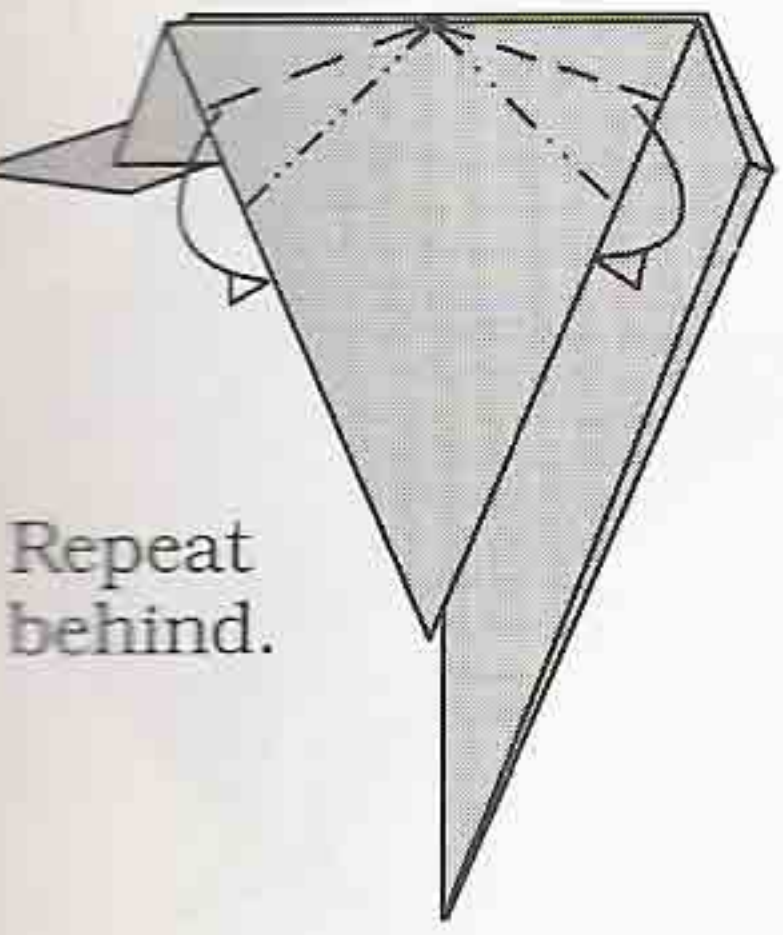

Repeat behind.

29

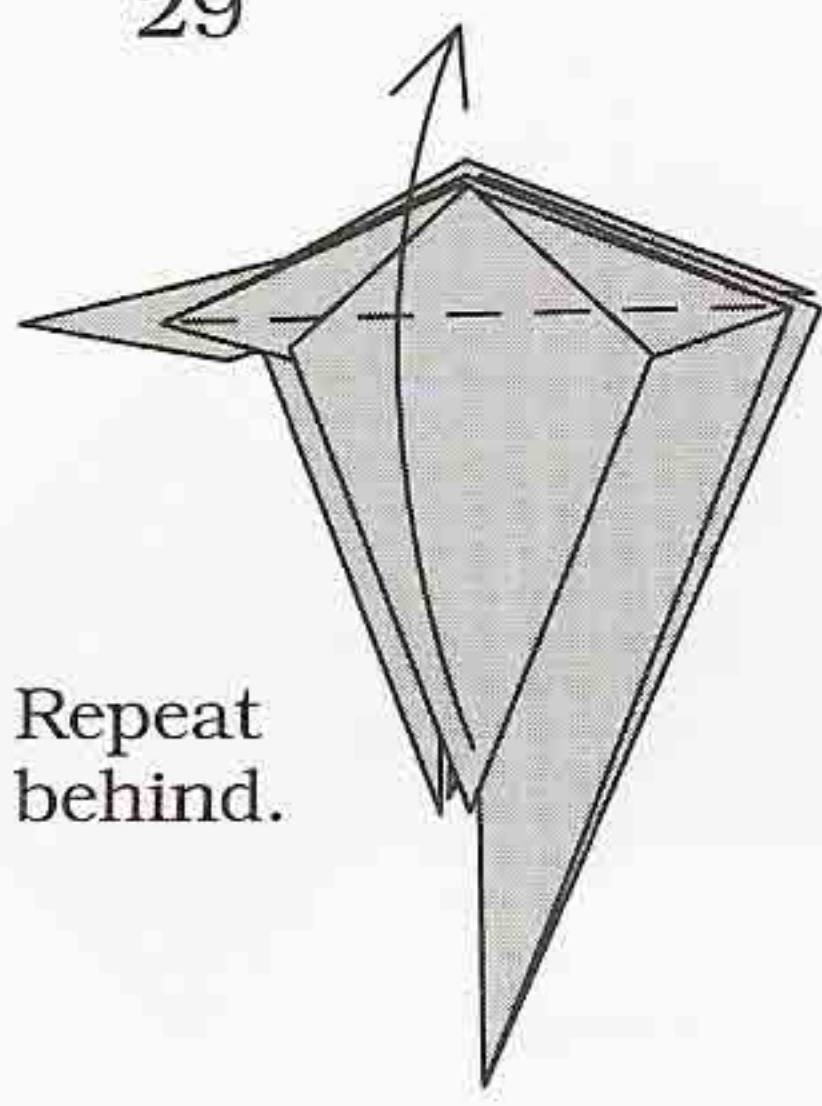

Repeat behind.

30

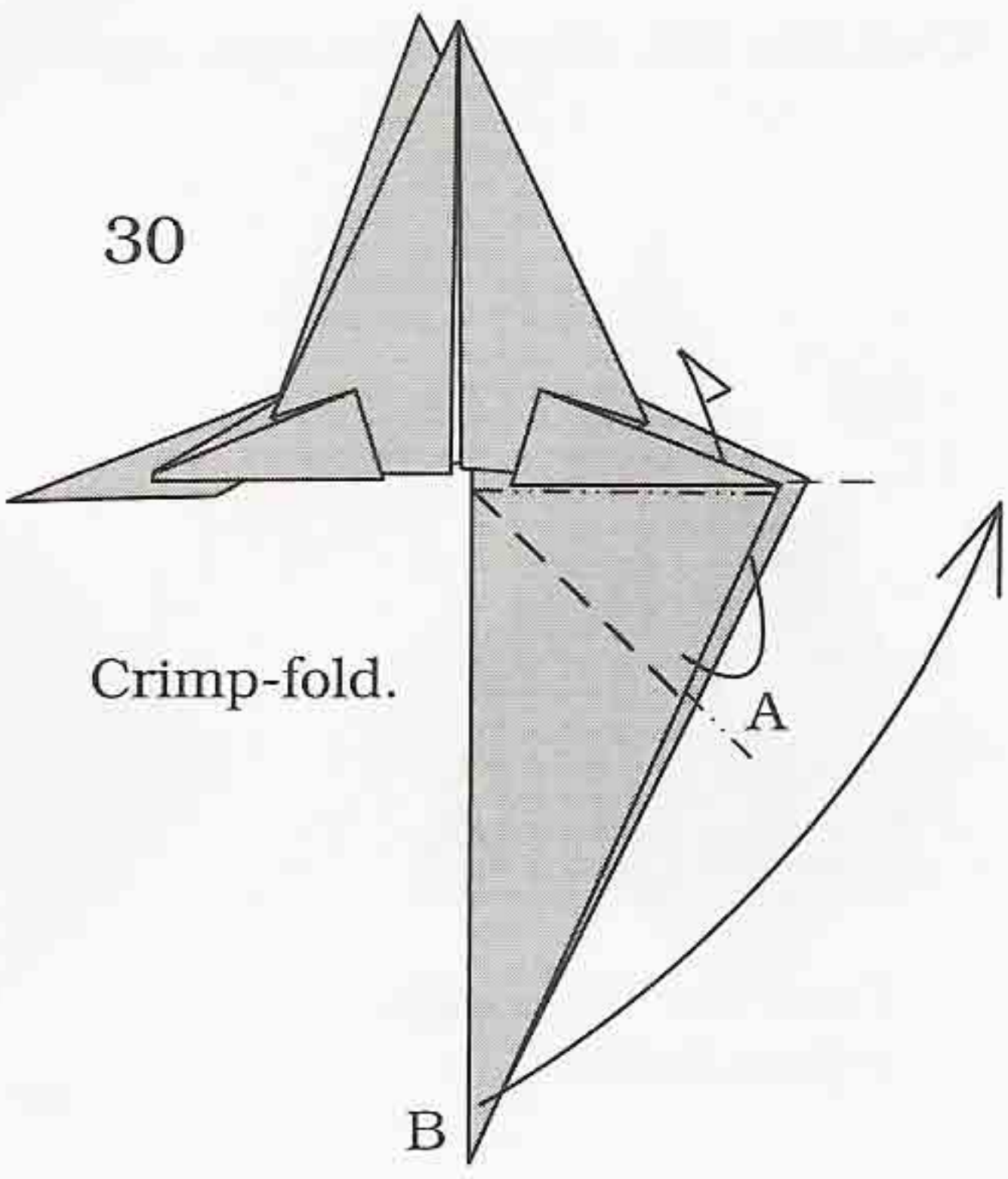

Crimp-fold.

31

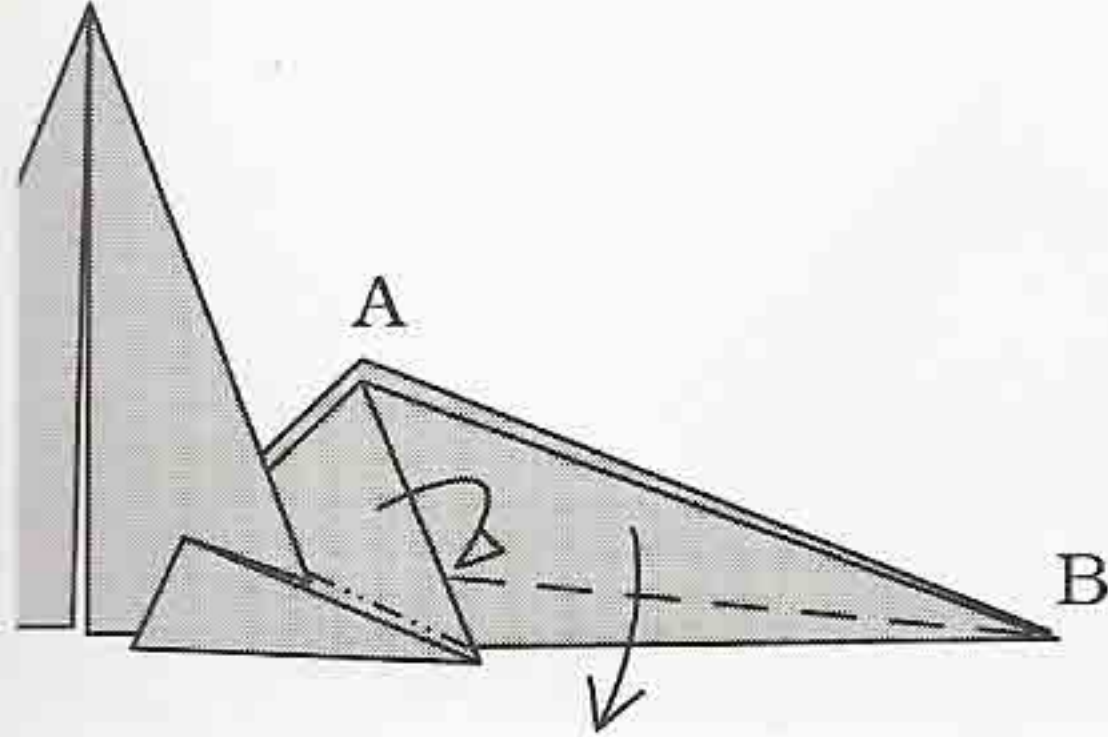

Reverse-fold, repeat behind.

32

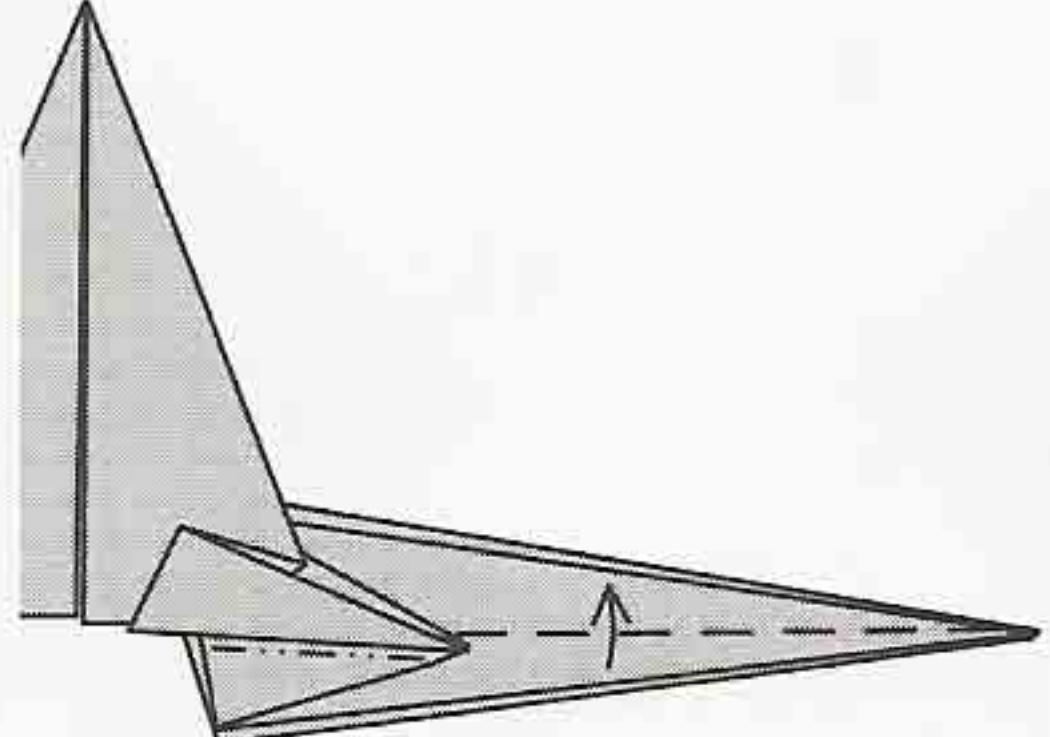

Reverse-fold, repeat behind.

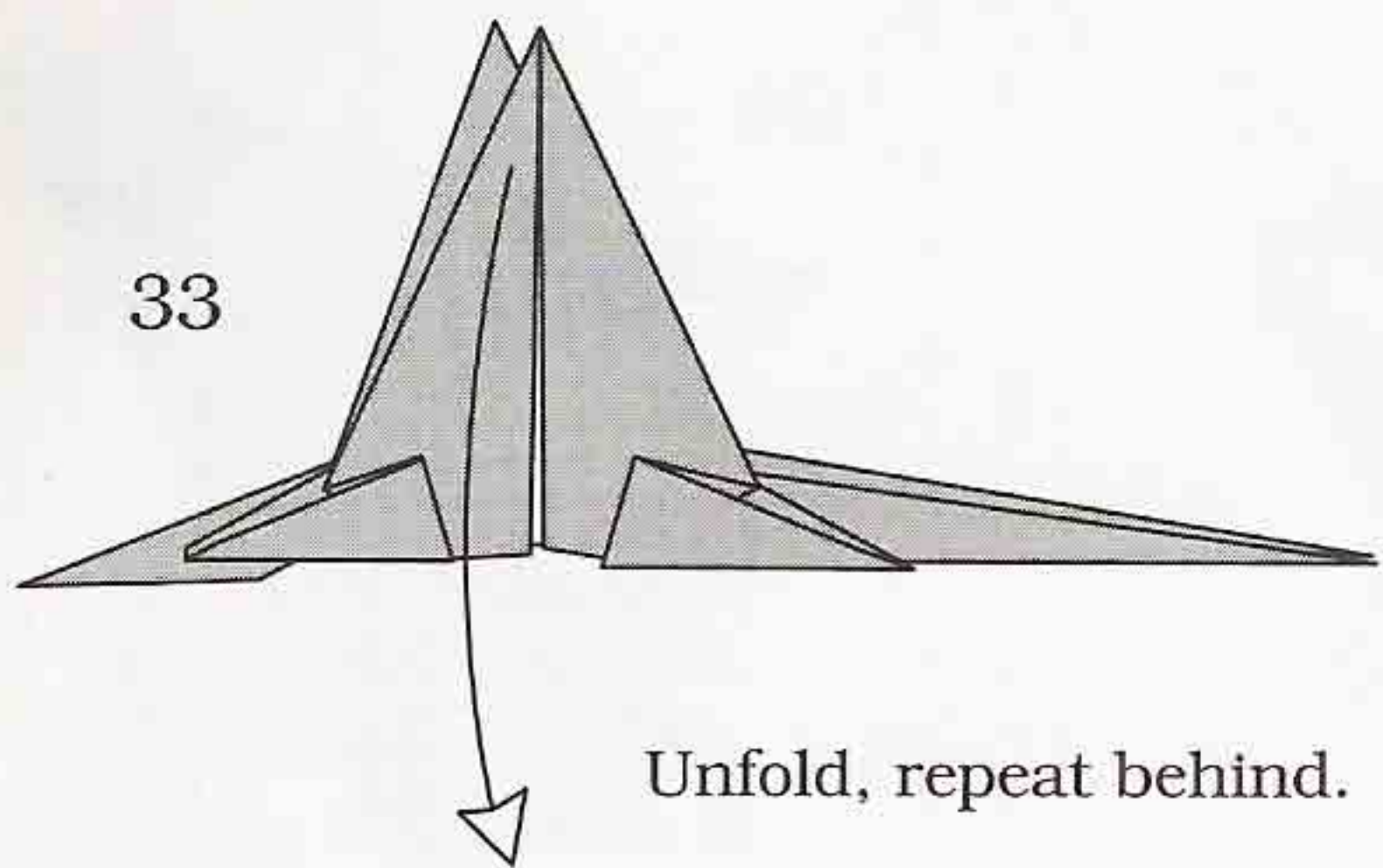

Unfold, repeat behind.

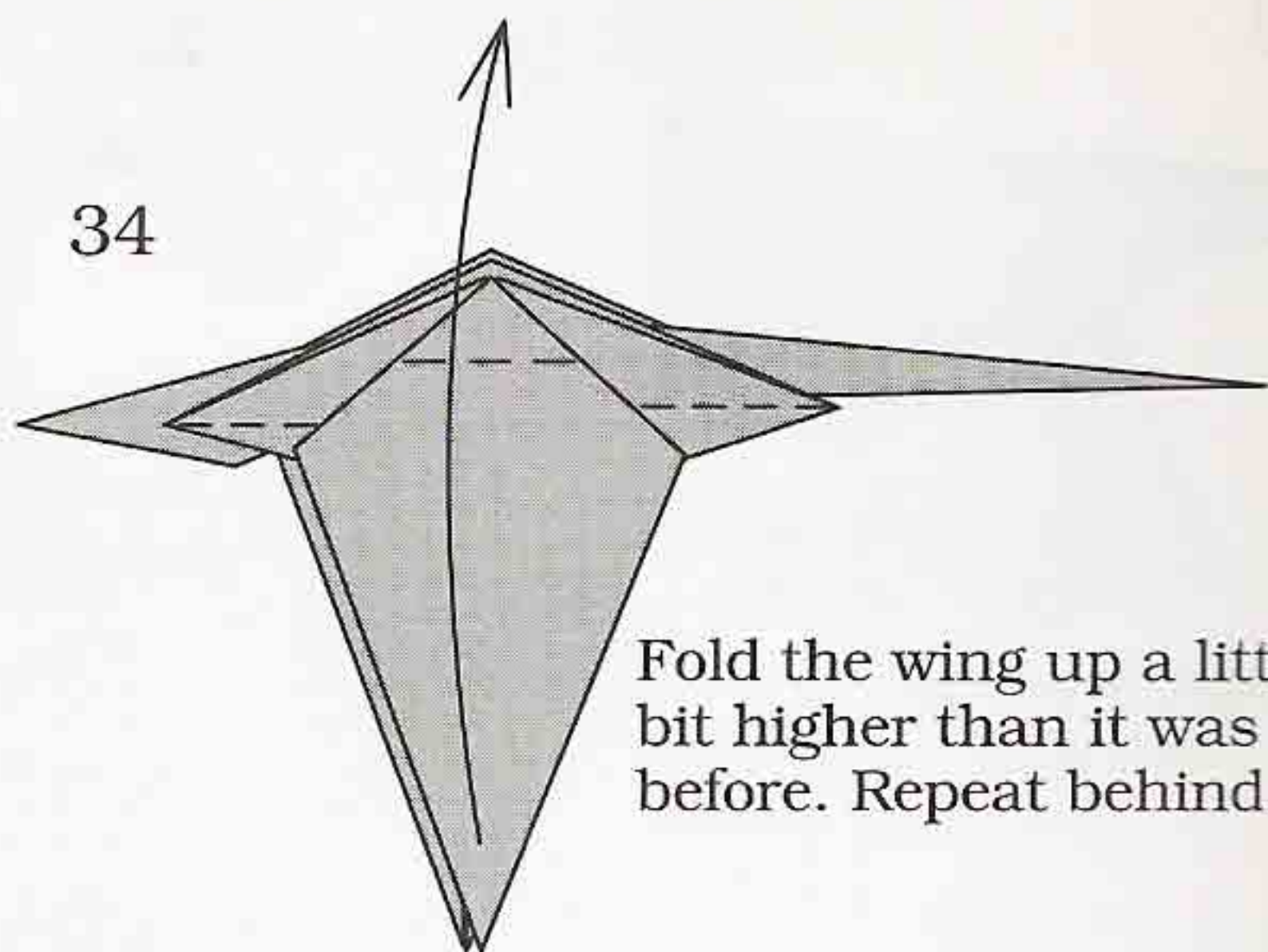

Fold the wing up a little bit higher than it was before. Repeat behind.

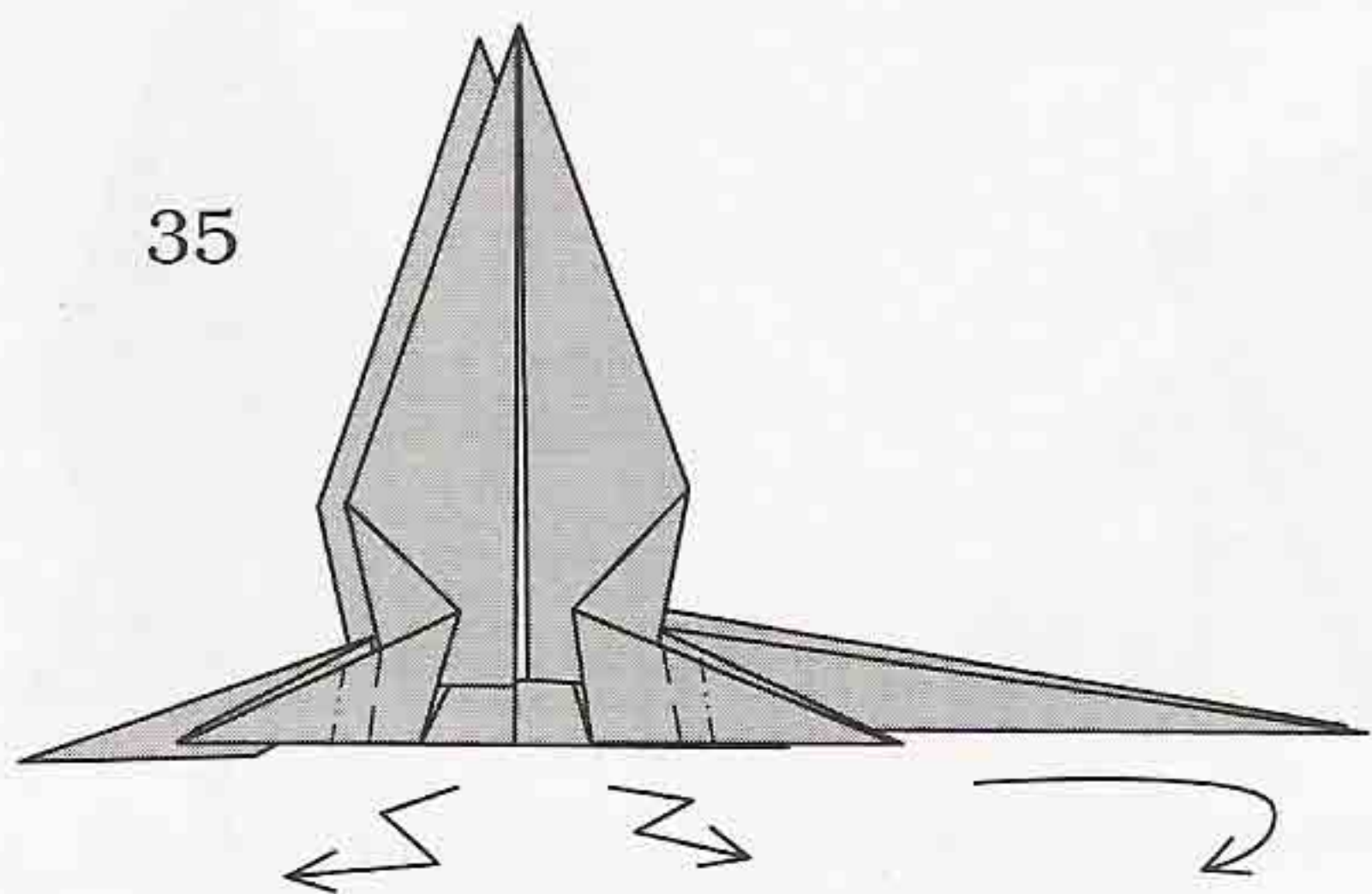

Curl the tail. Shape the legs, repeat behind.

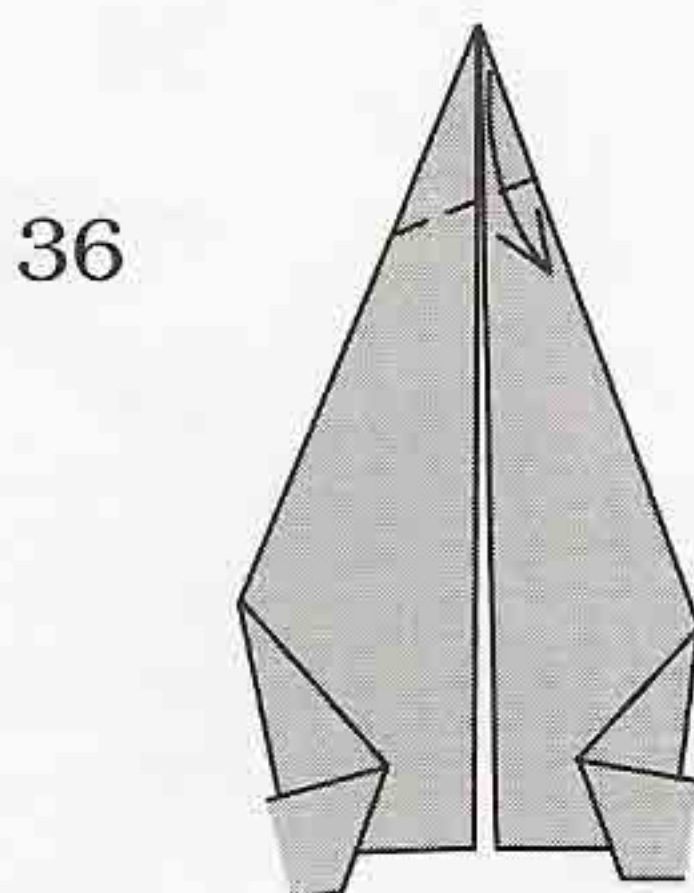

Repeat behind.

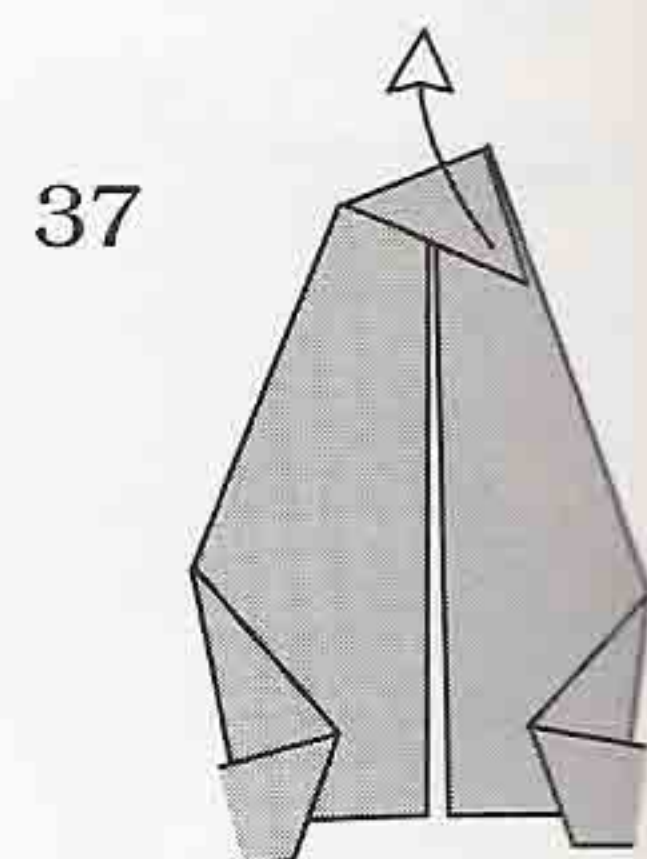

Unfold, repeat behind.

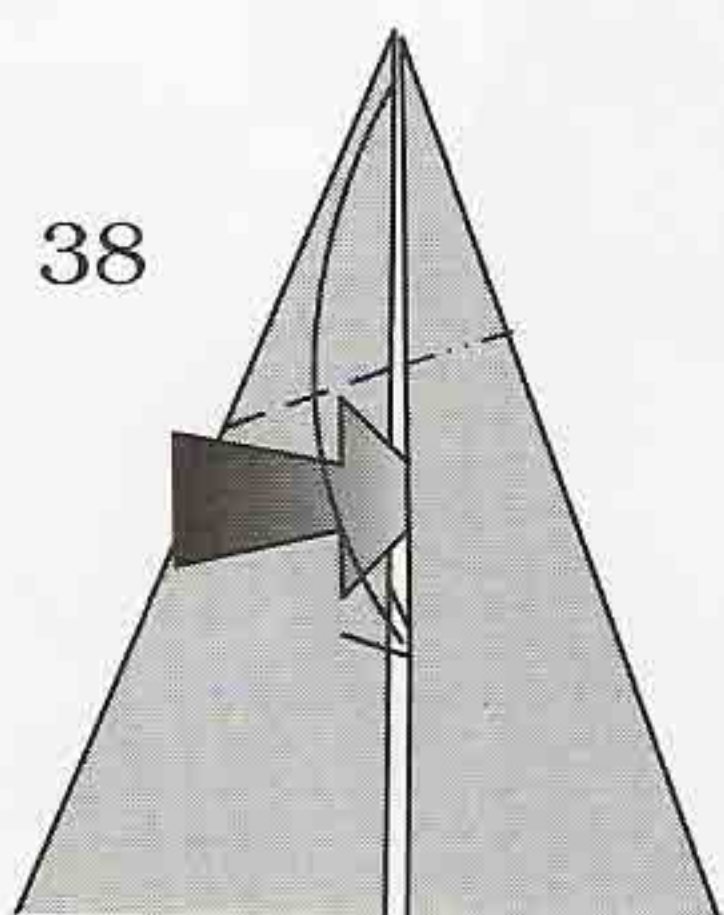

Tuck the tip inside, repeat behind.

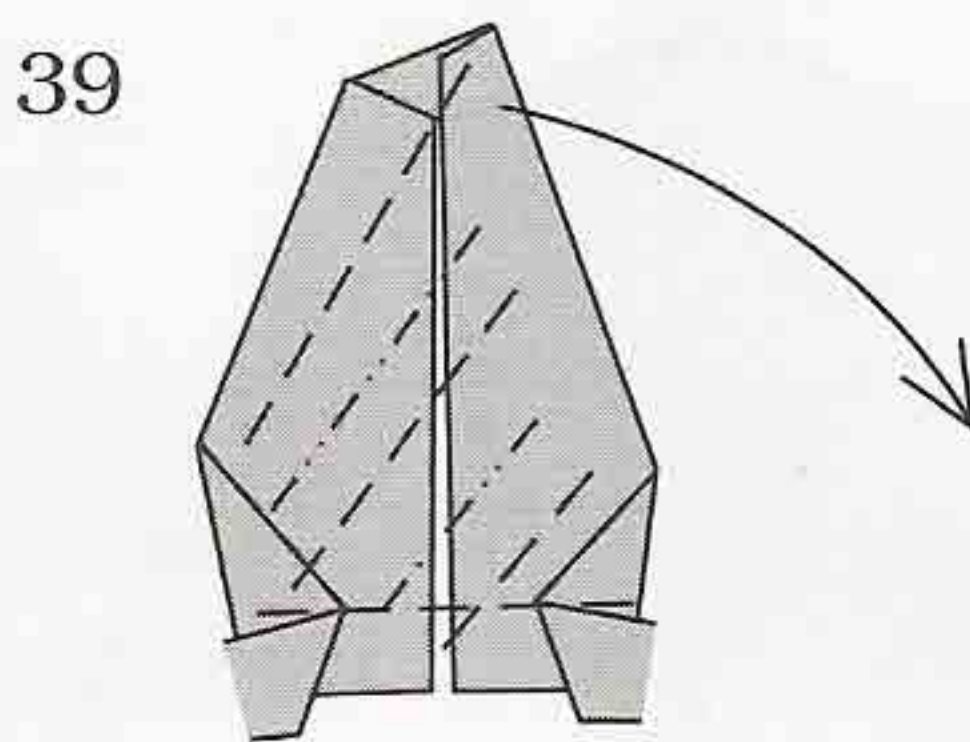

Repeat behind.

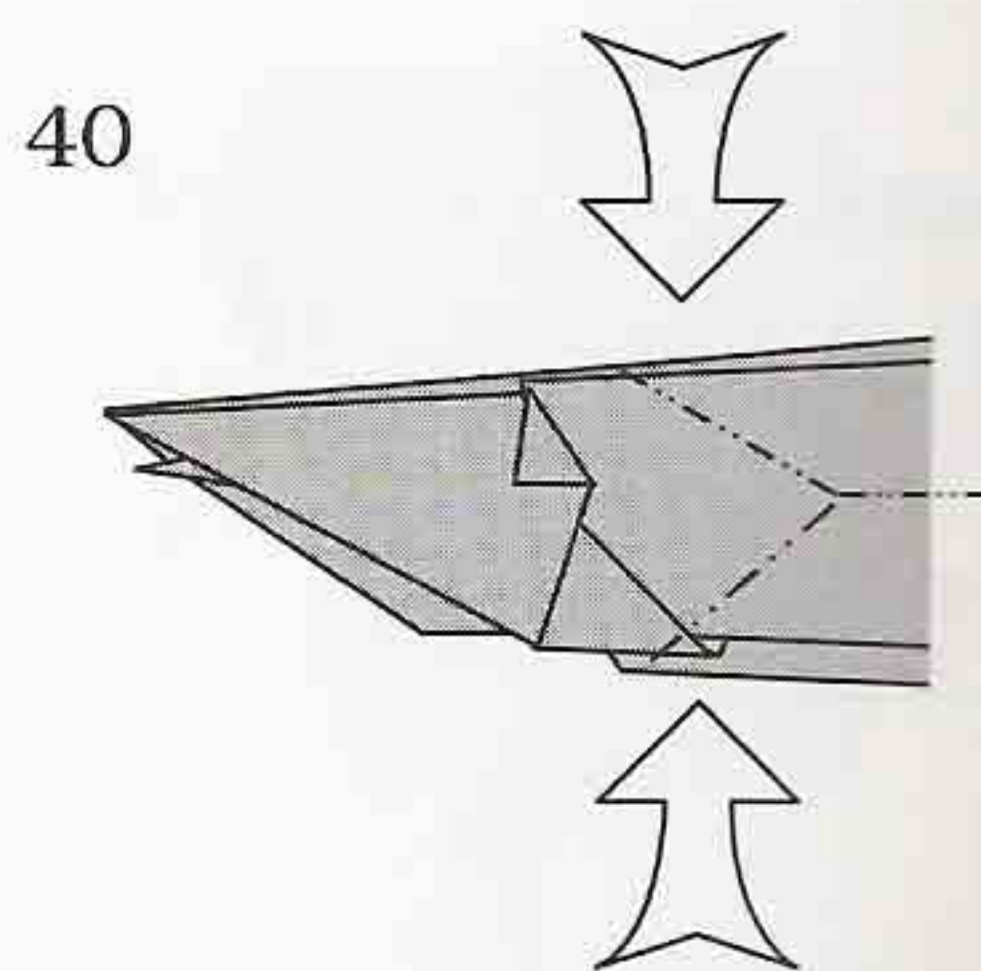

Sculp the head and neck by making it three-dimensional.

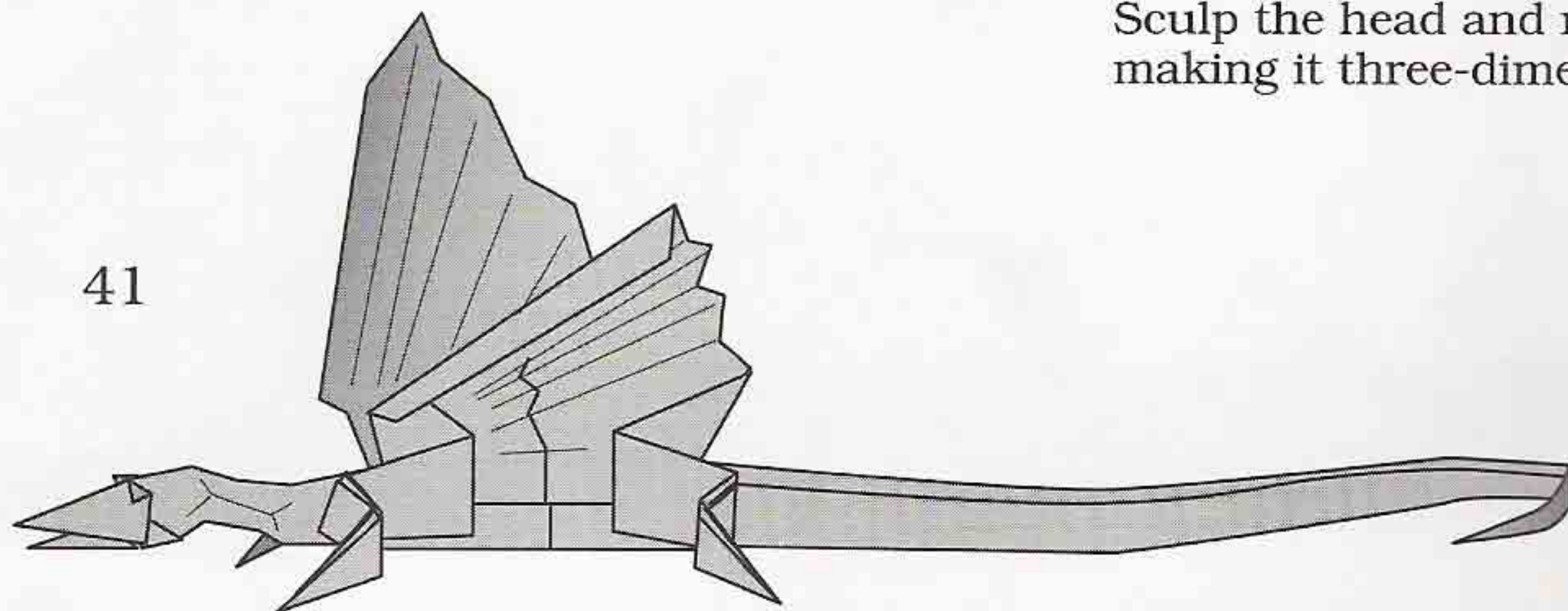

Kuehneosaurus

Parasaurolophus

par-a-SAUR-oh-loaf-us

A swamp dwelling, Cretaceous plant eater, this dinosaur was 33 feet long. The webbed feet and bill were not the only similarities to ducks. The long tubular crest on the top of the head may have enabled it to honk like a goose. It had grinding teeth in the back of the mouth. Parasaurolophus means "almost crest head" and it may have been the female to Corythosaurus.

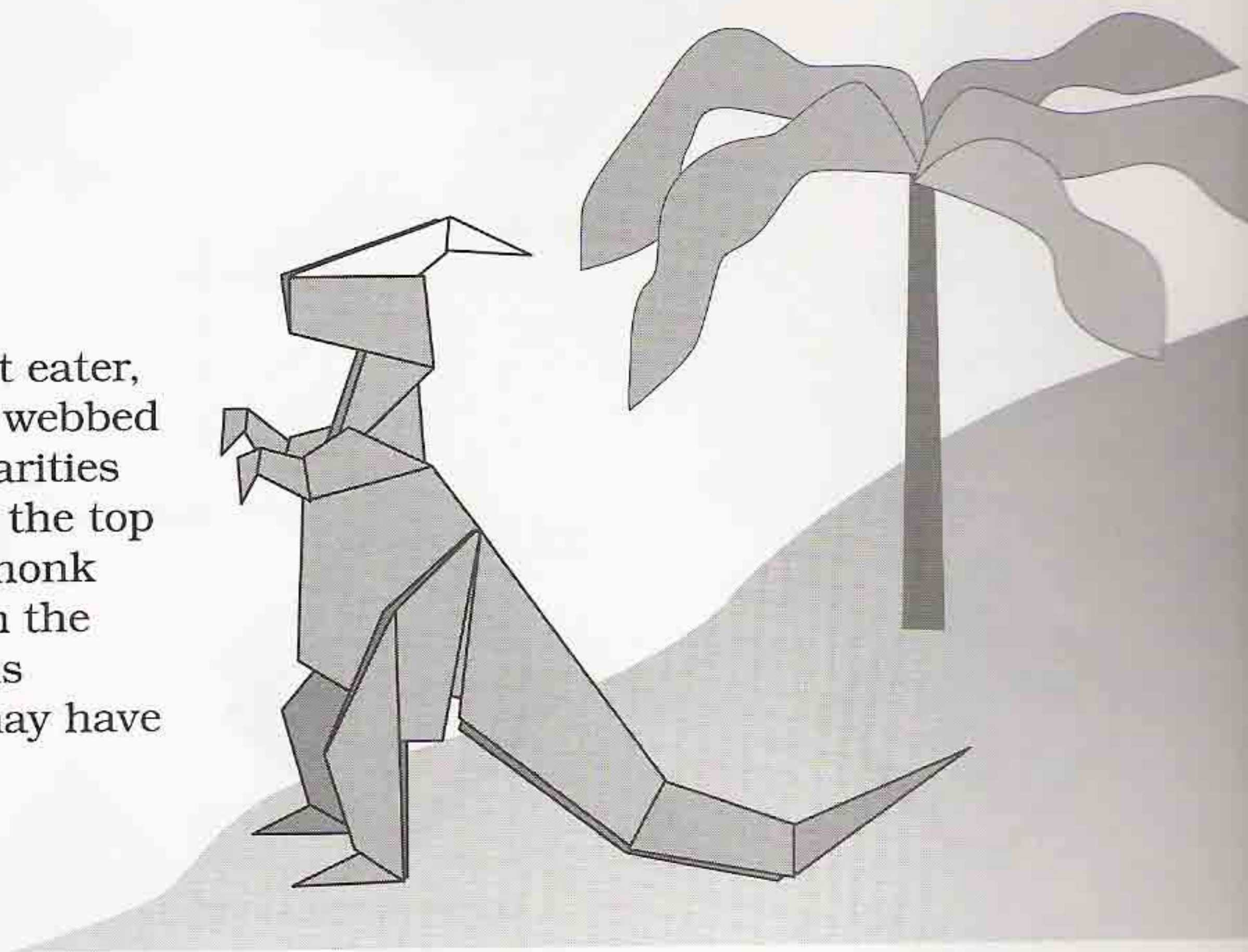

Begin with the Bird Base (page 18).

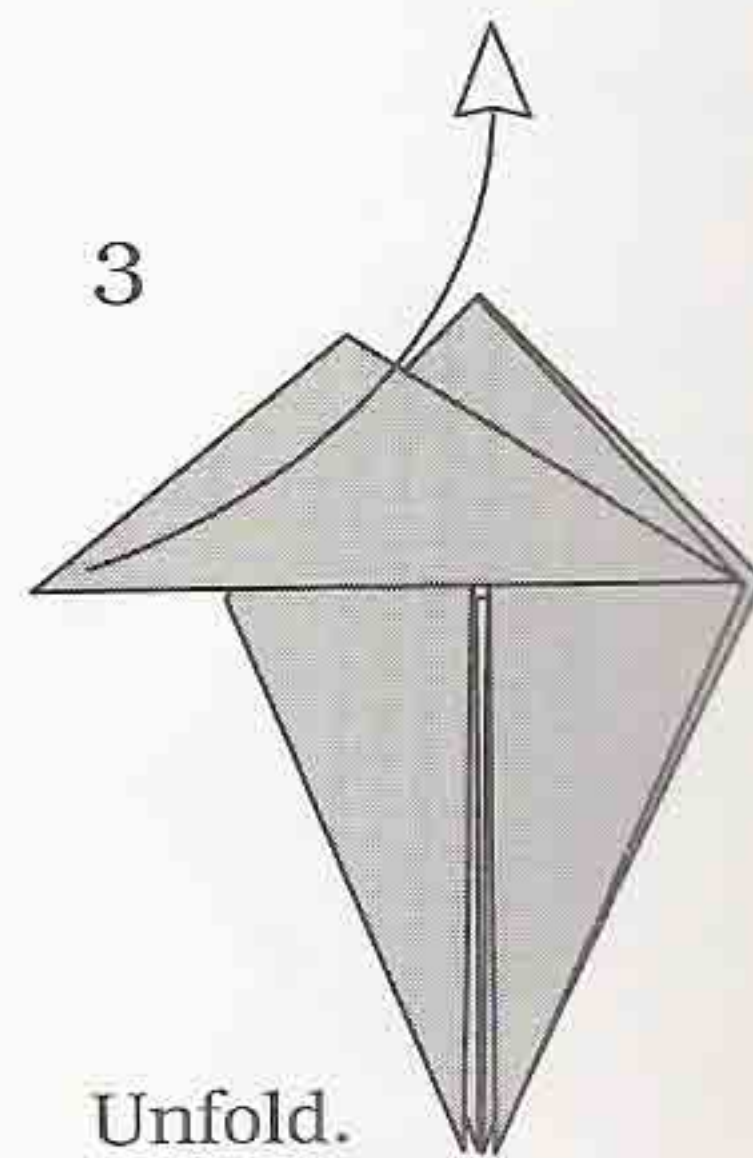
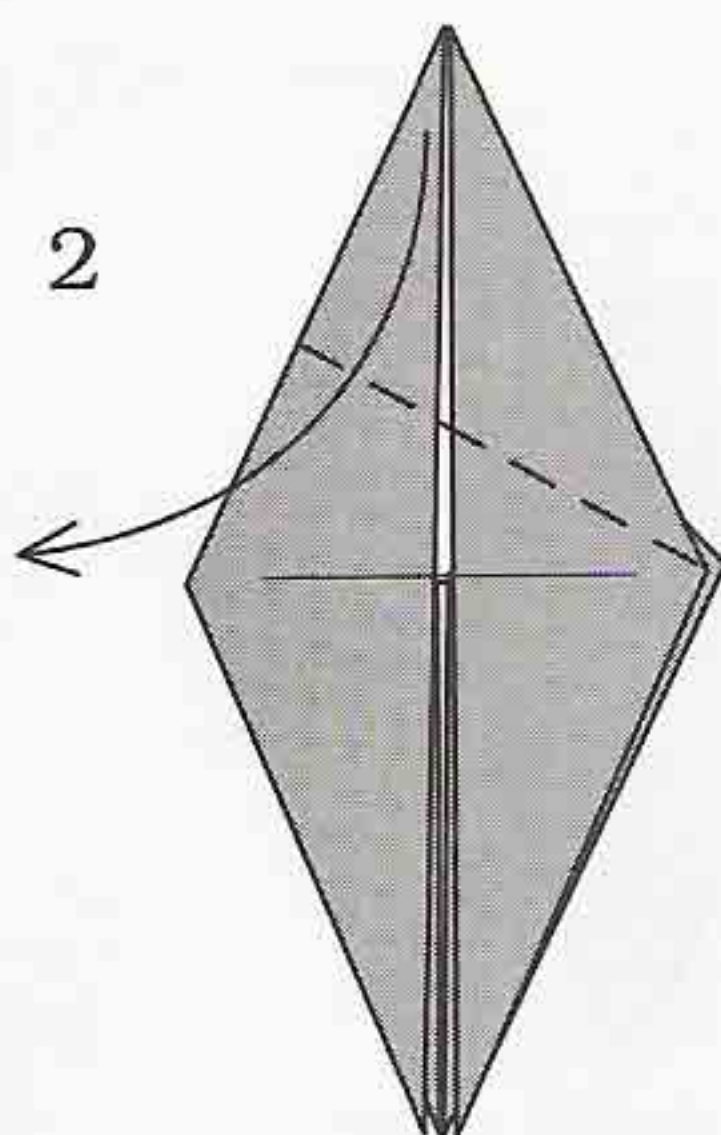
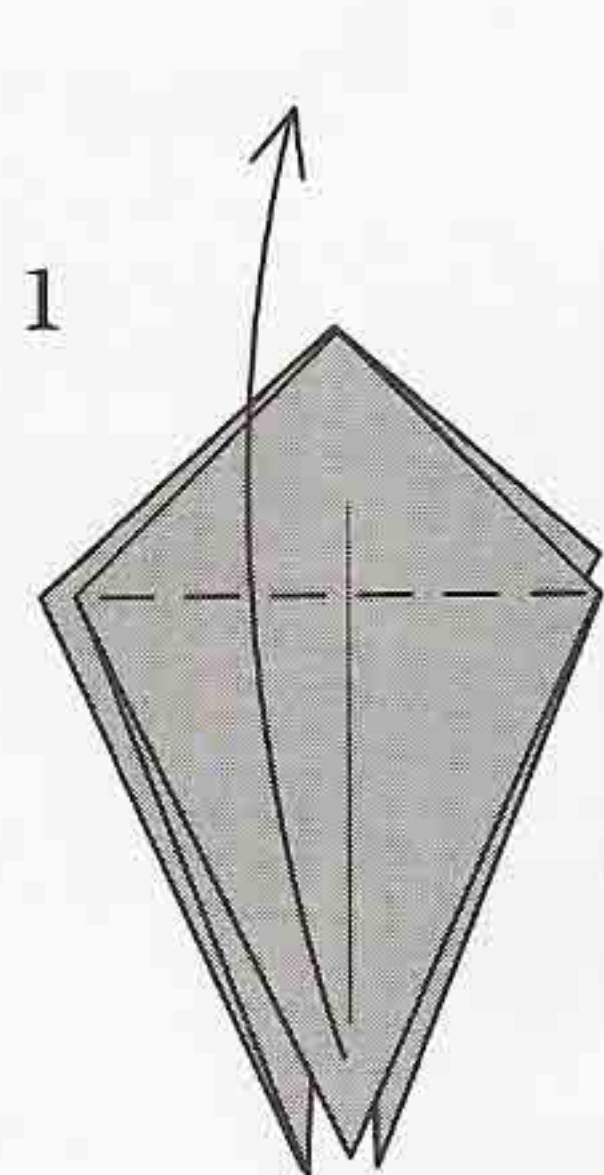

Unfold.

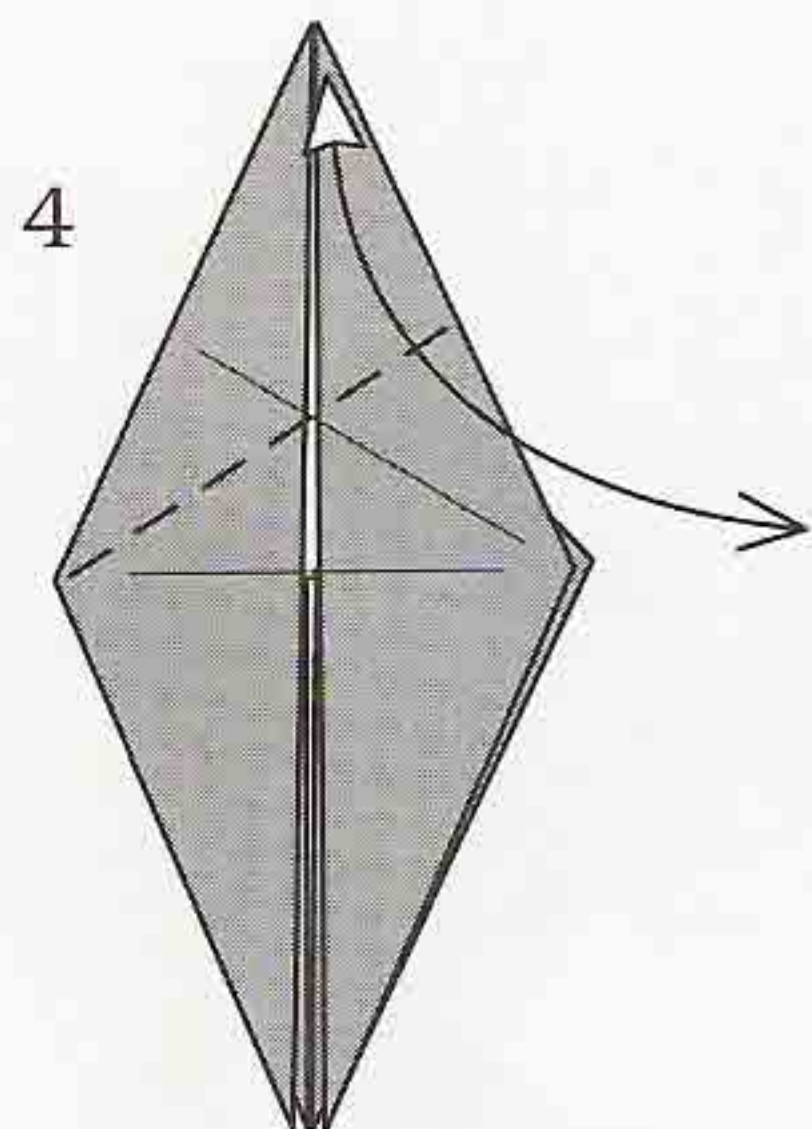

Fold and unfold.

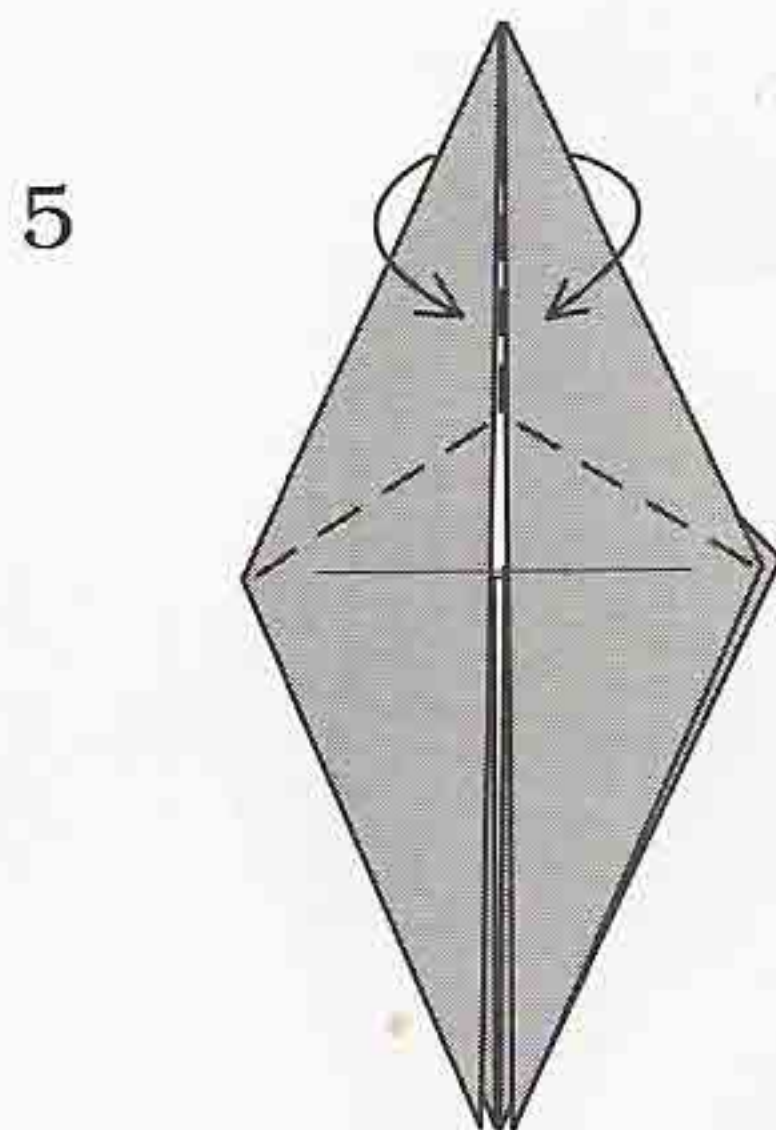

A rabbit ear will now be formed. To begin, fold the two sides of the tip towards the center. Step 7 shows the completed rabbit ear.

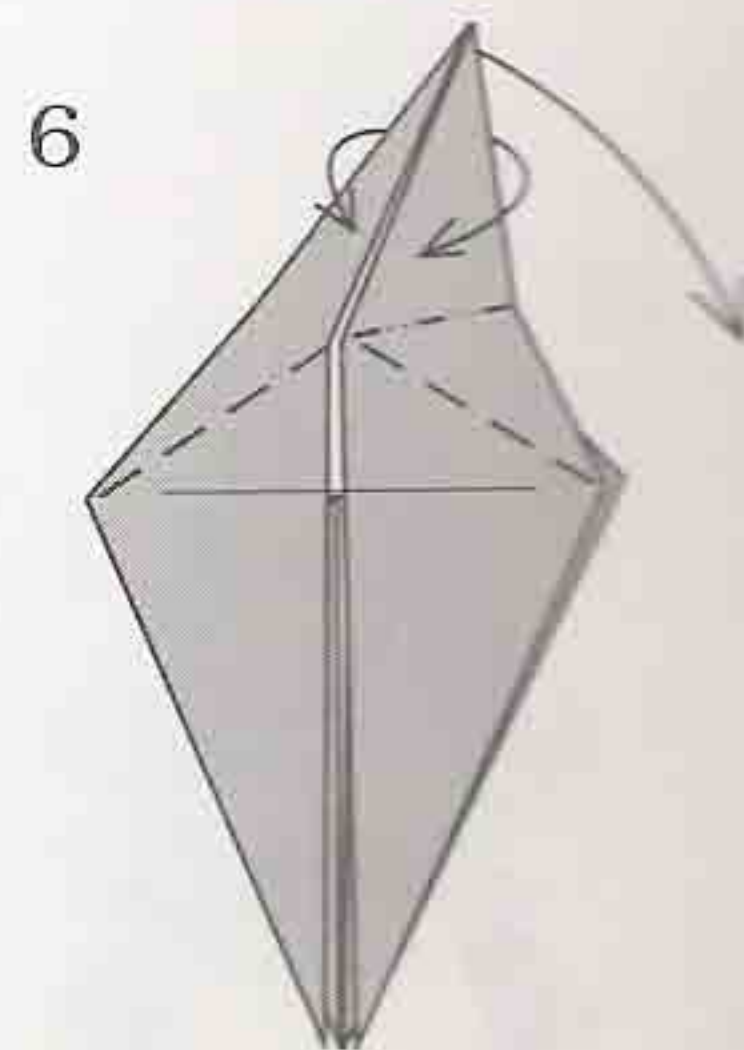

This three-dimensional figure shows the rabbit ear in progress.

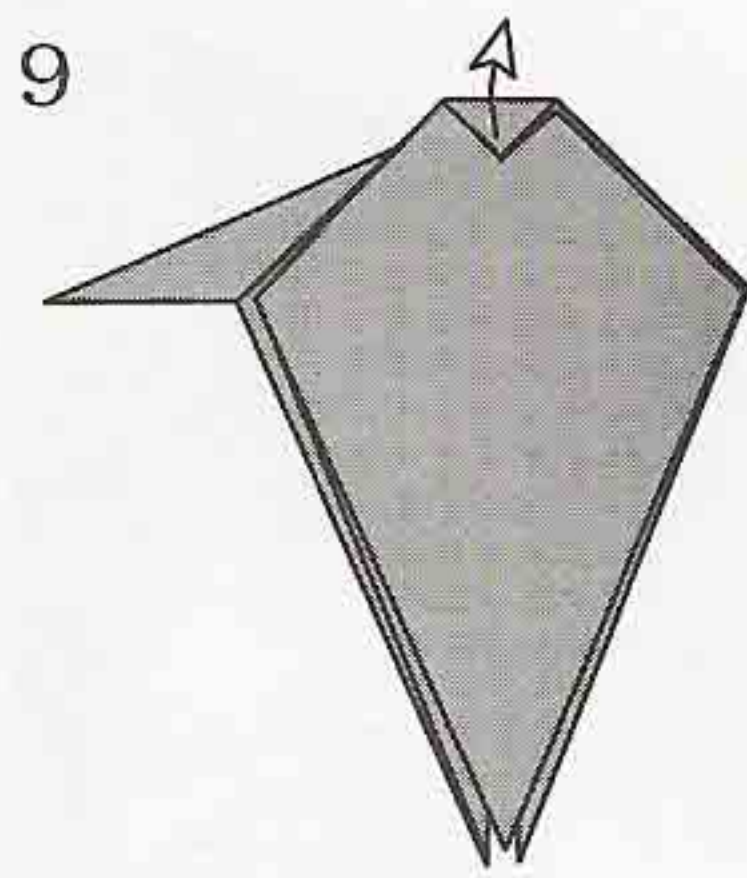
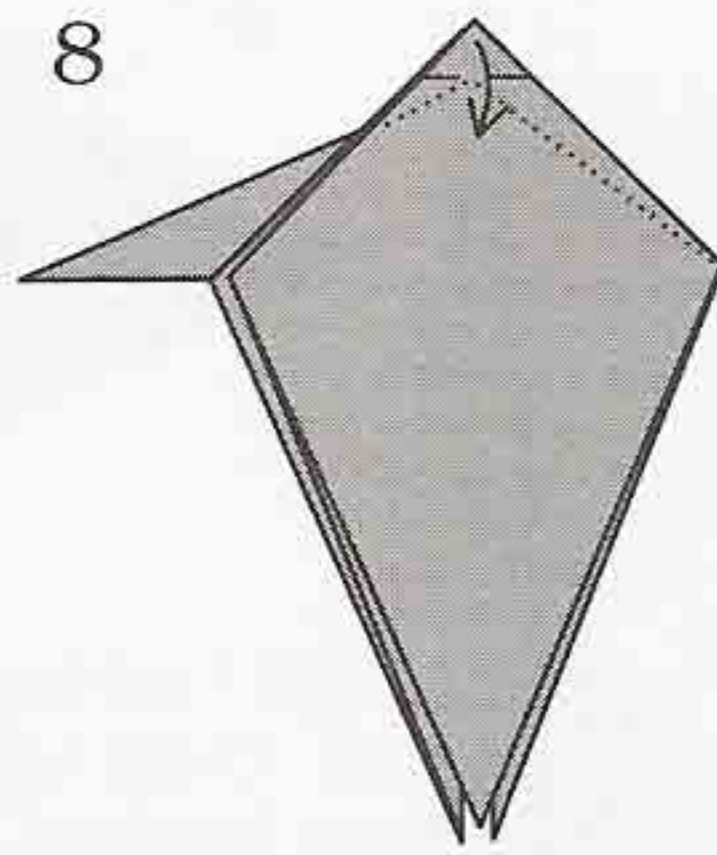
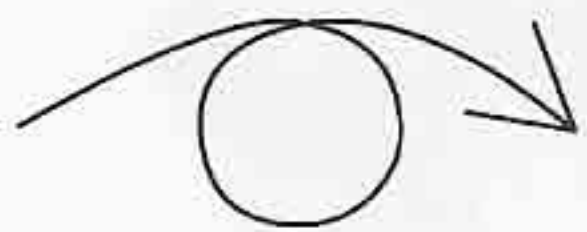
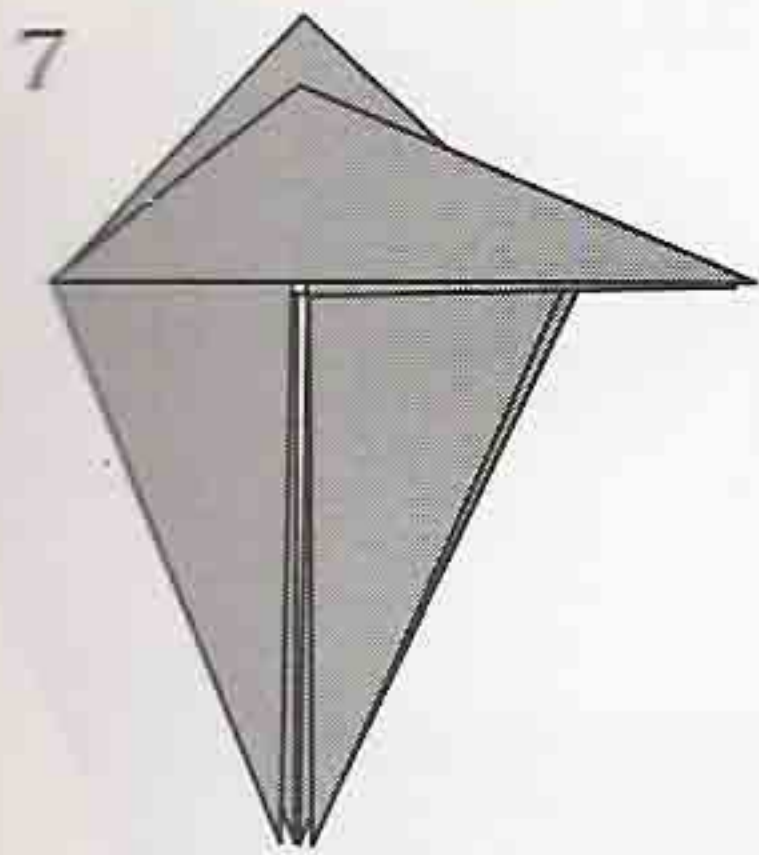

Unfold.

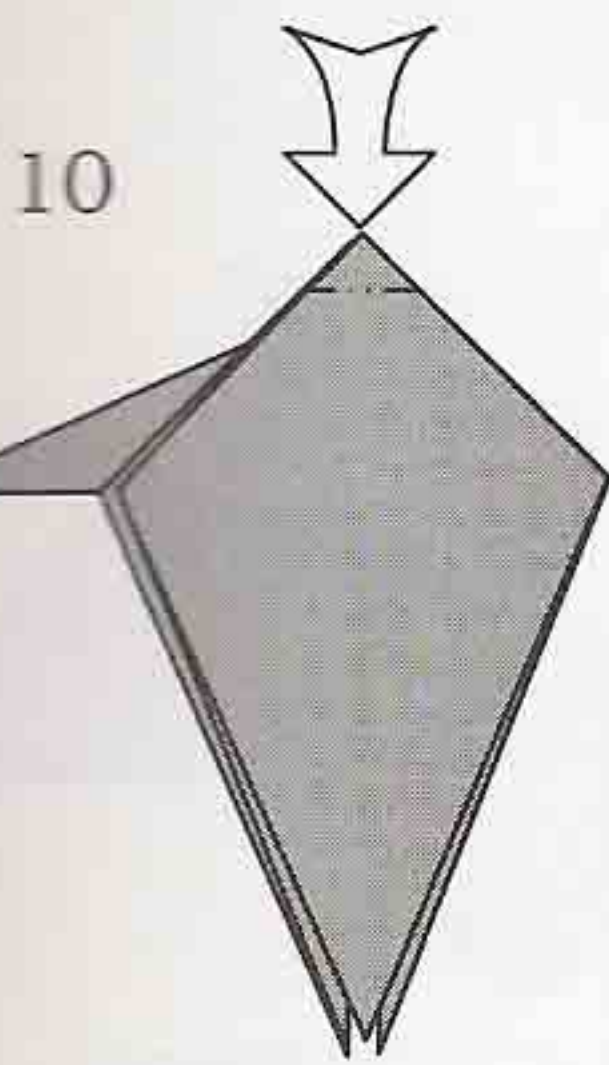

Sink.

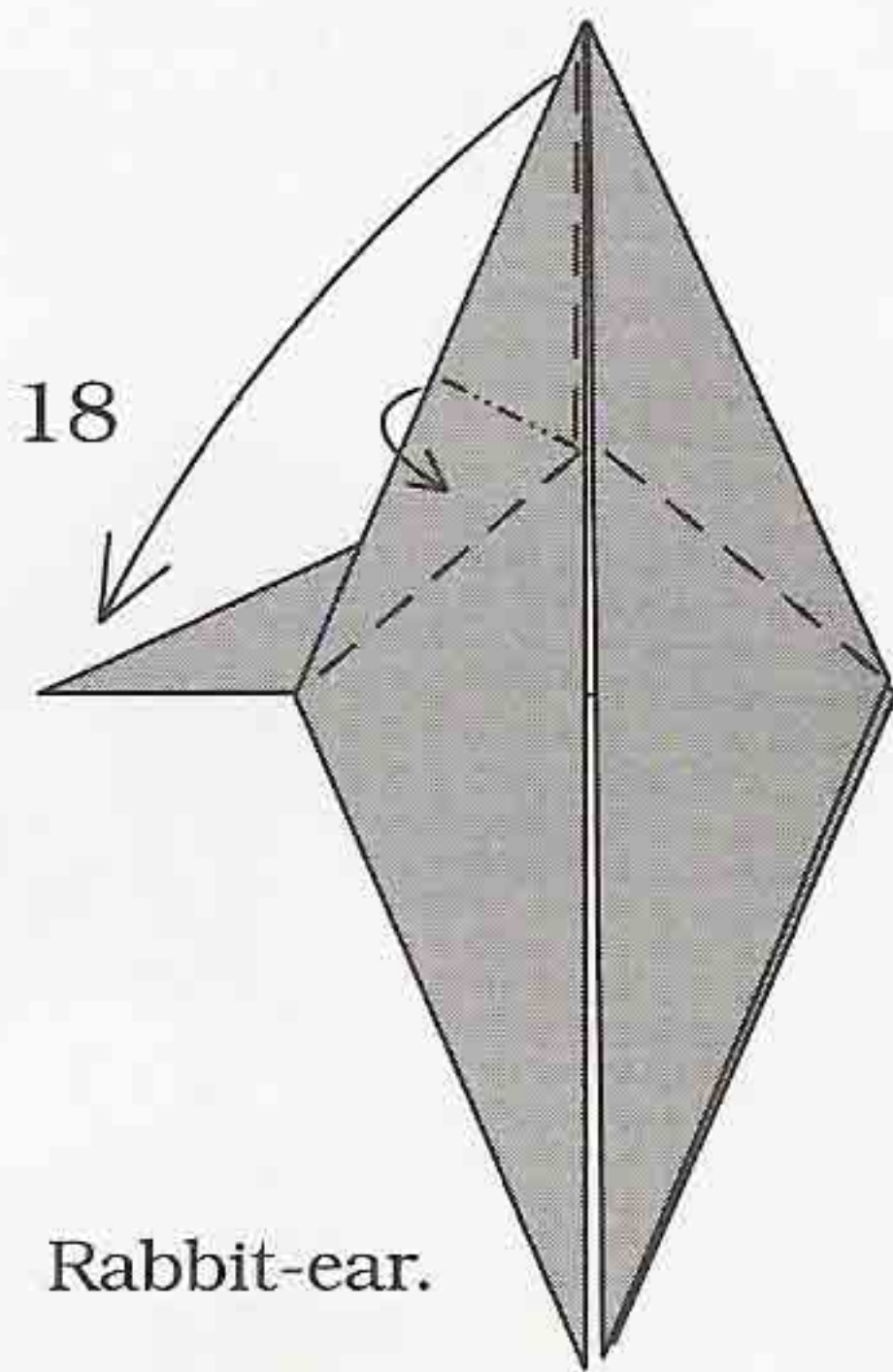
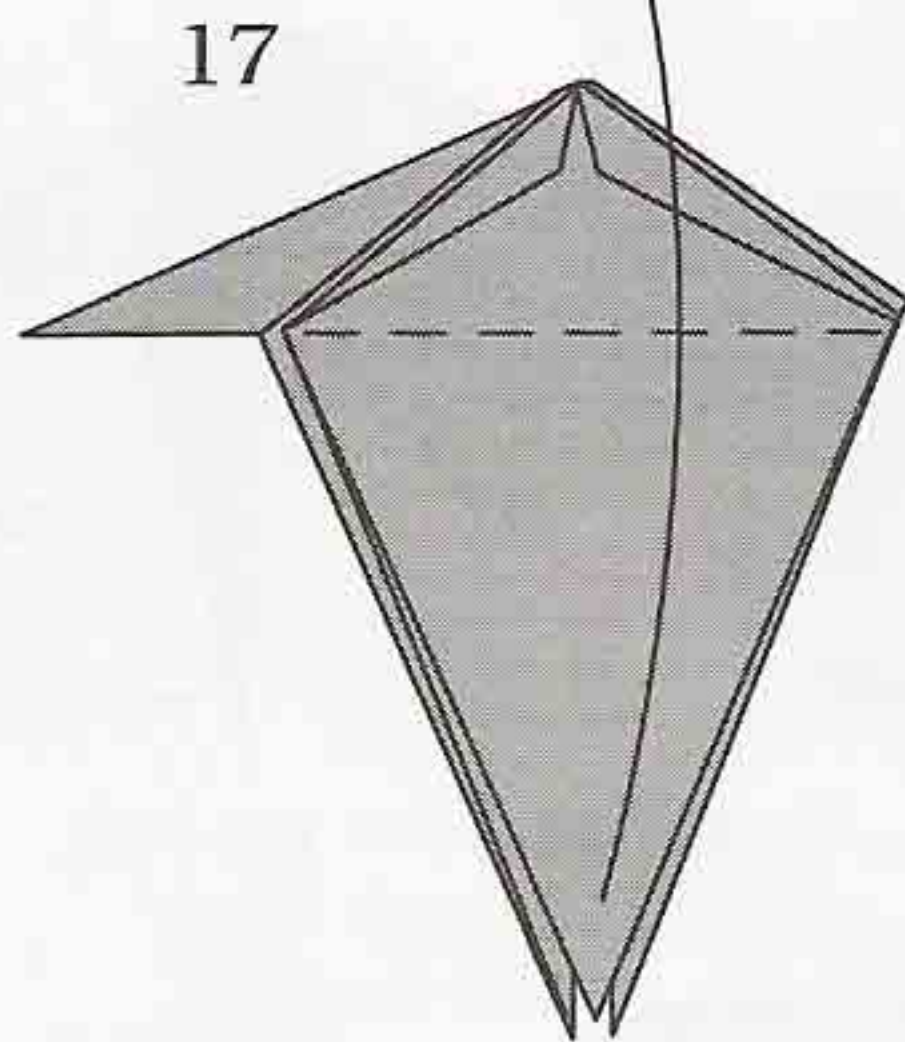
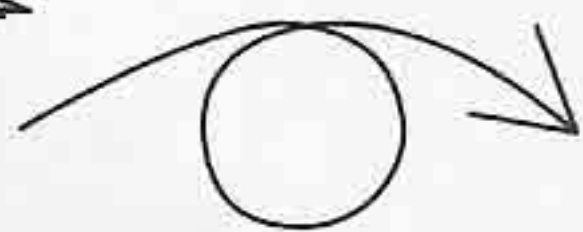
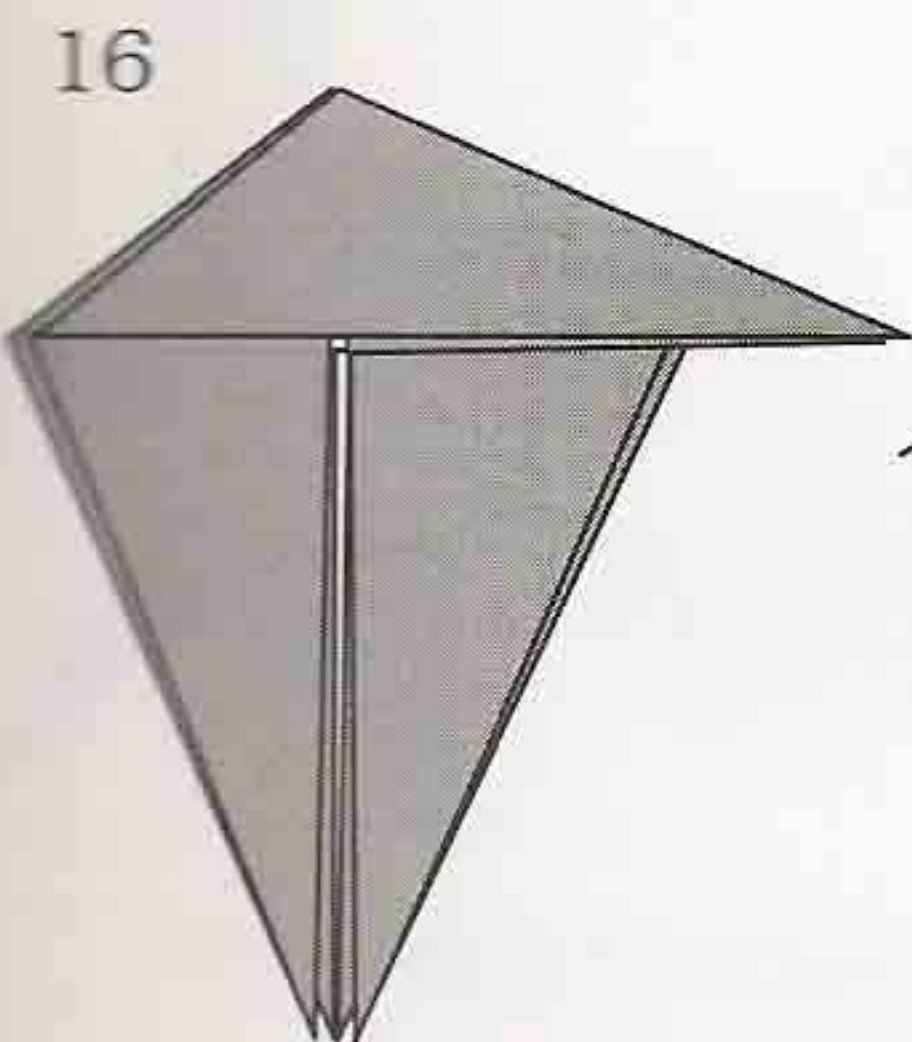
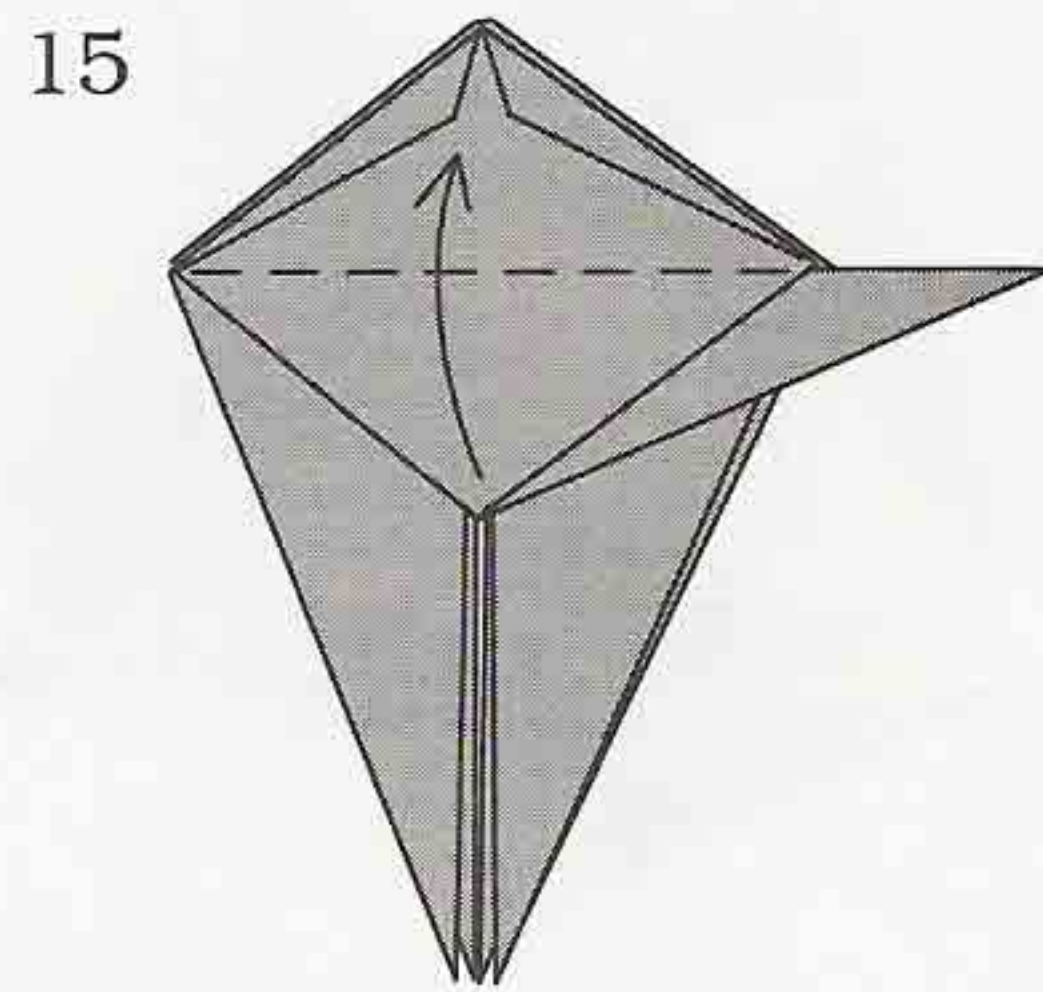
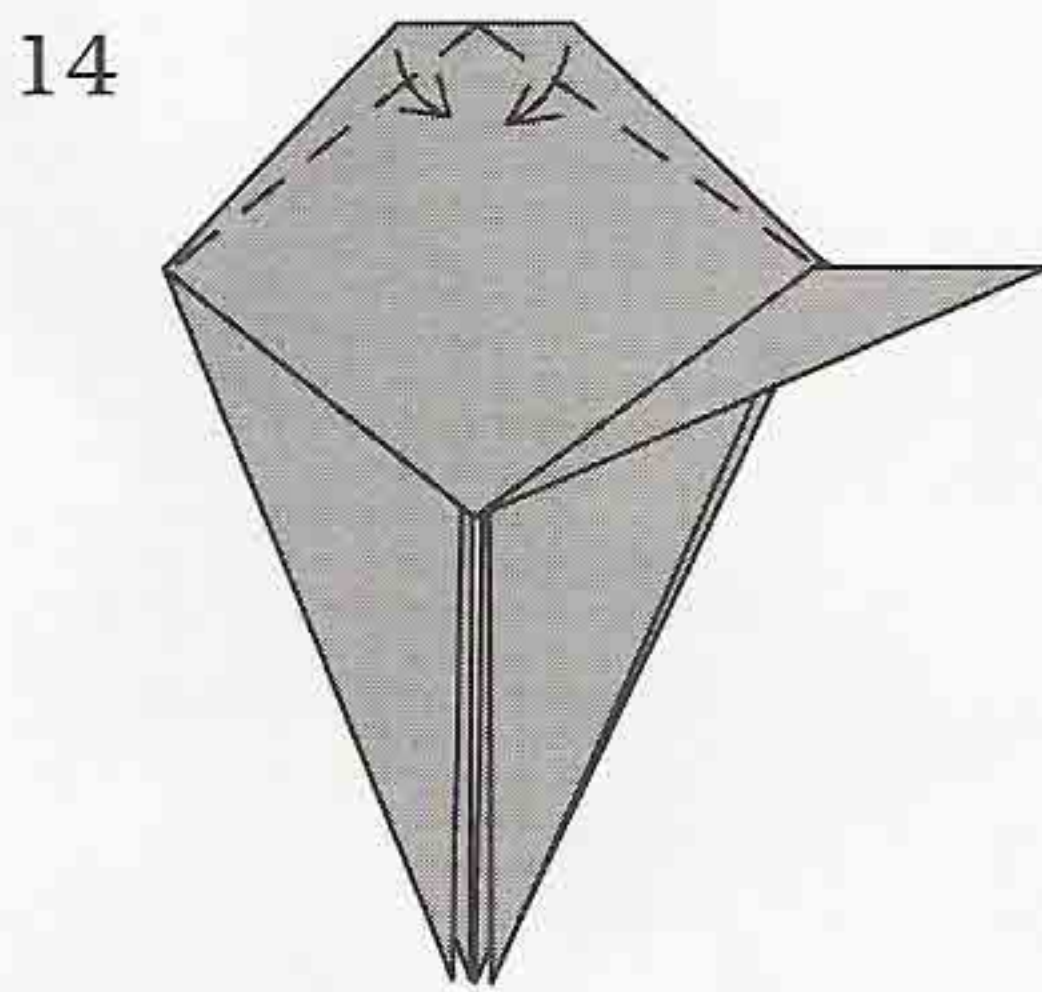
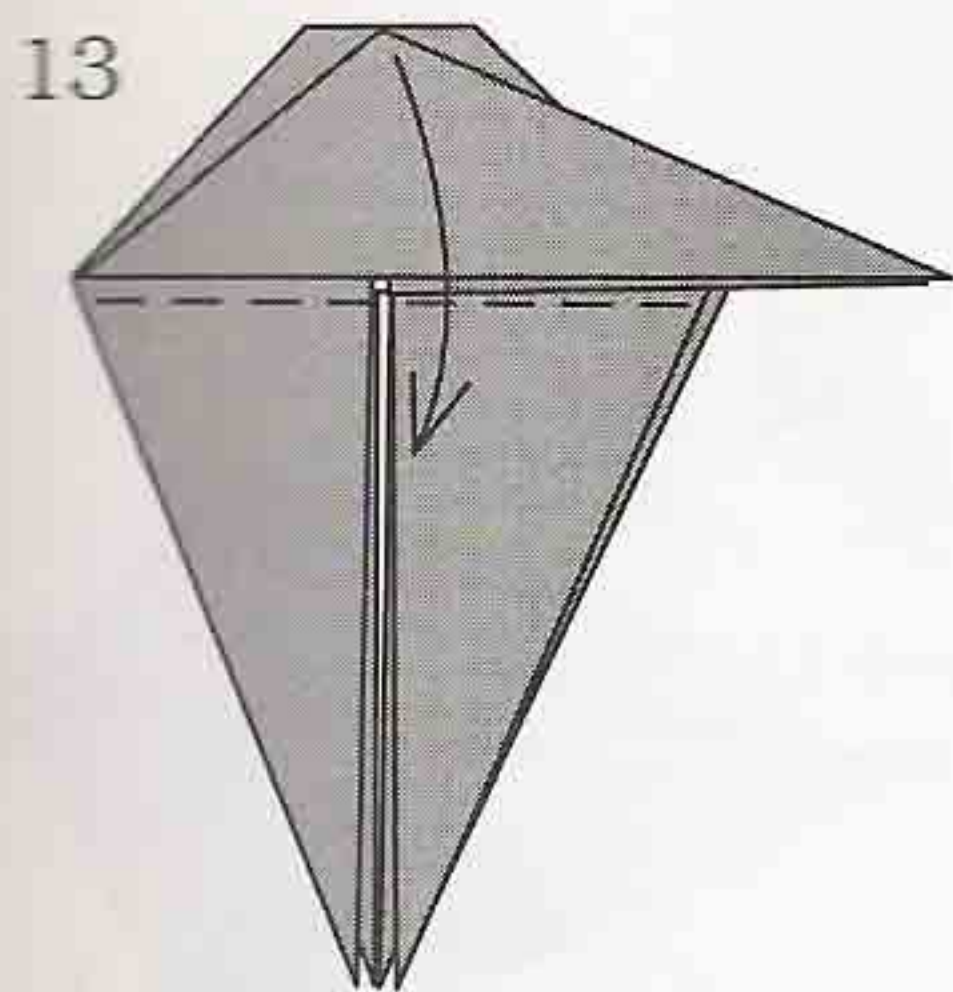
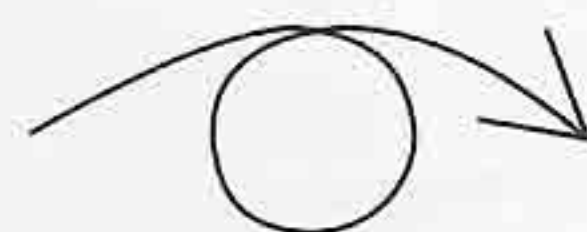
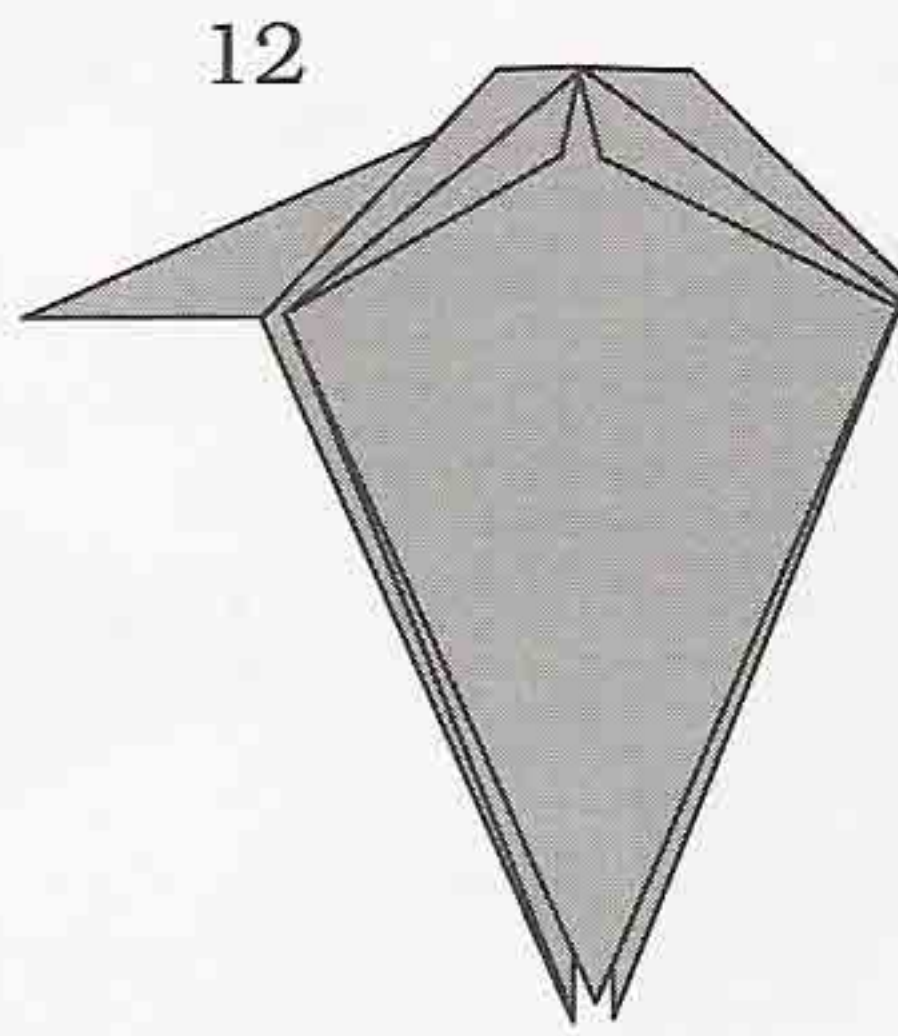
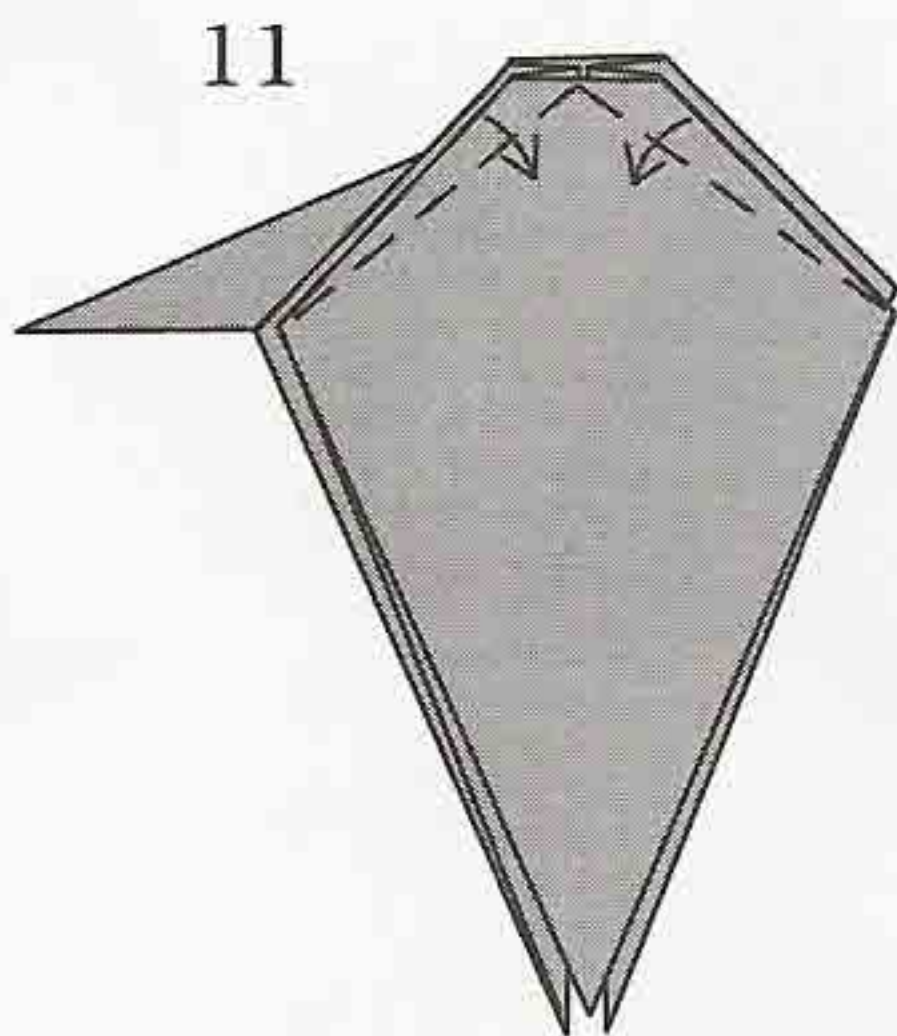

Rabbit-ear.

19

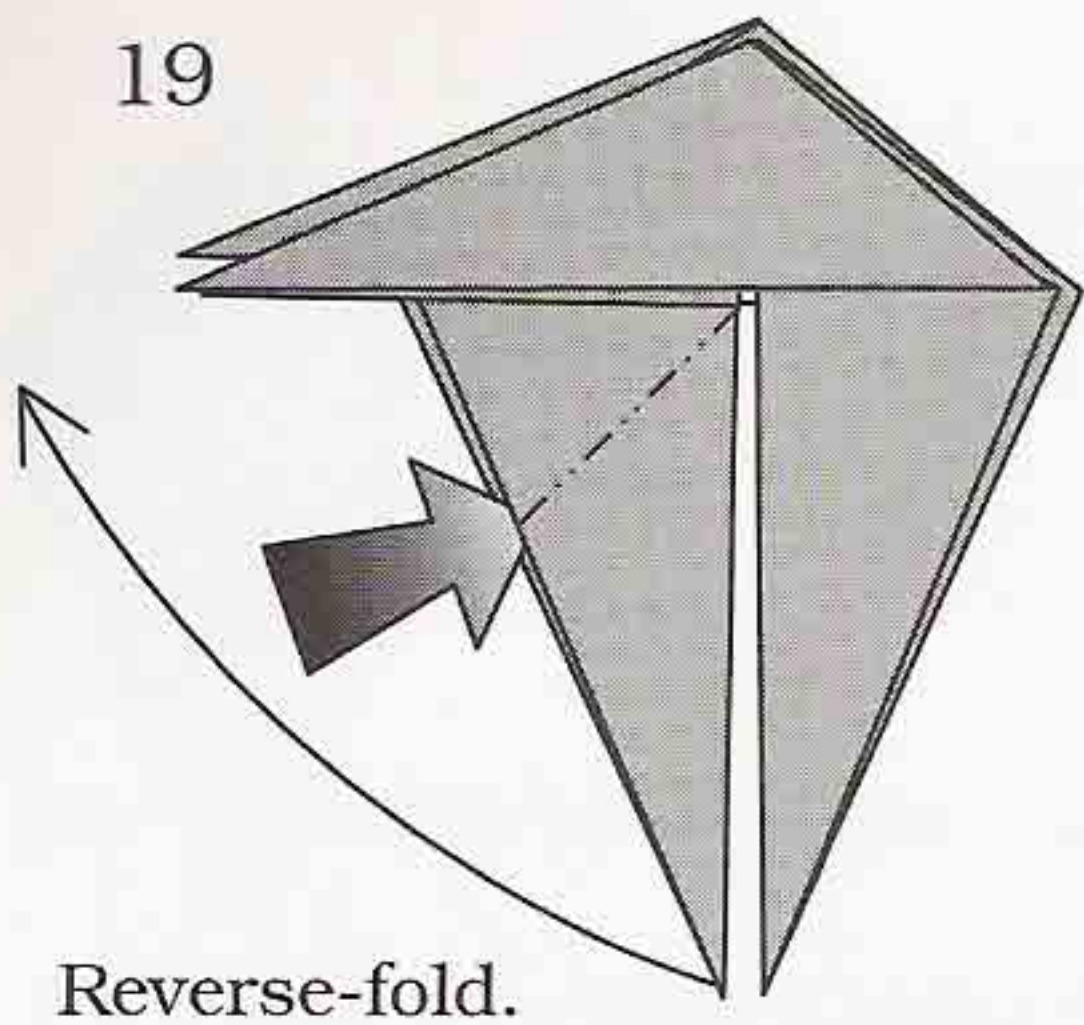

Reverse-fold.

20

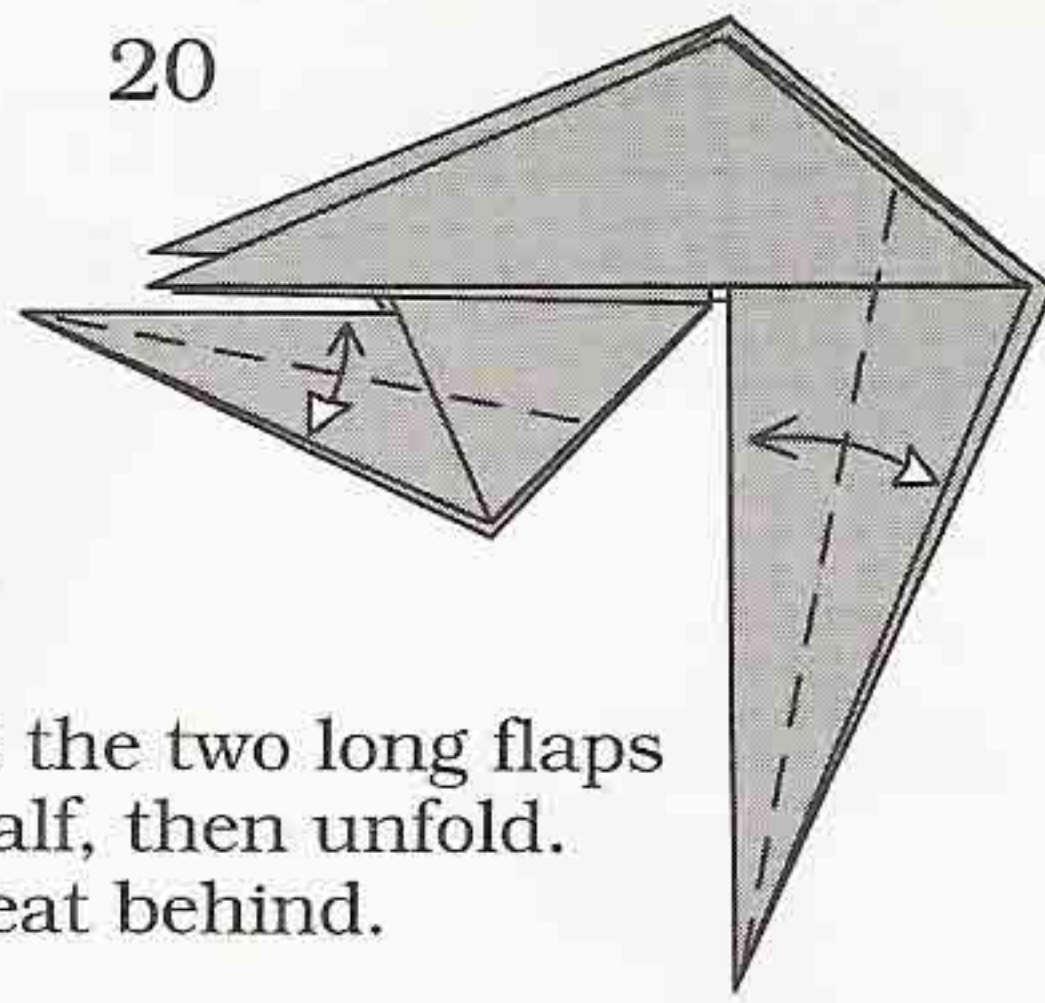

Fold the two long flaps in half, then unfold. Repeat behind.

21

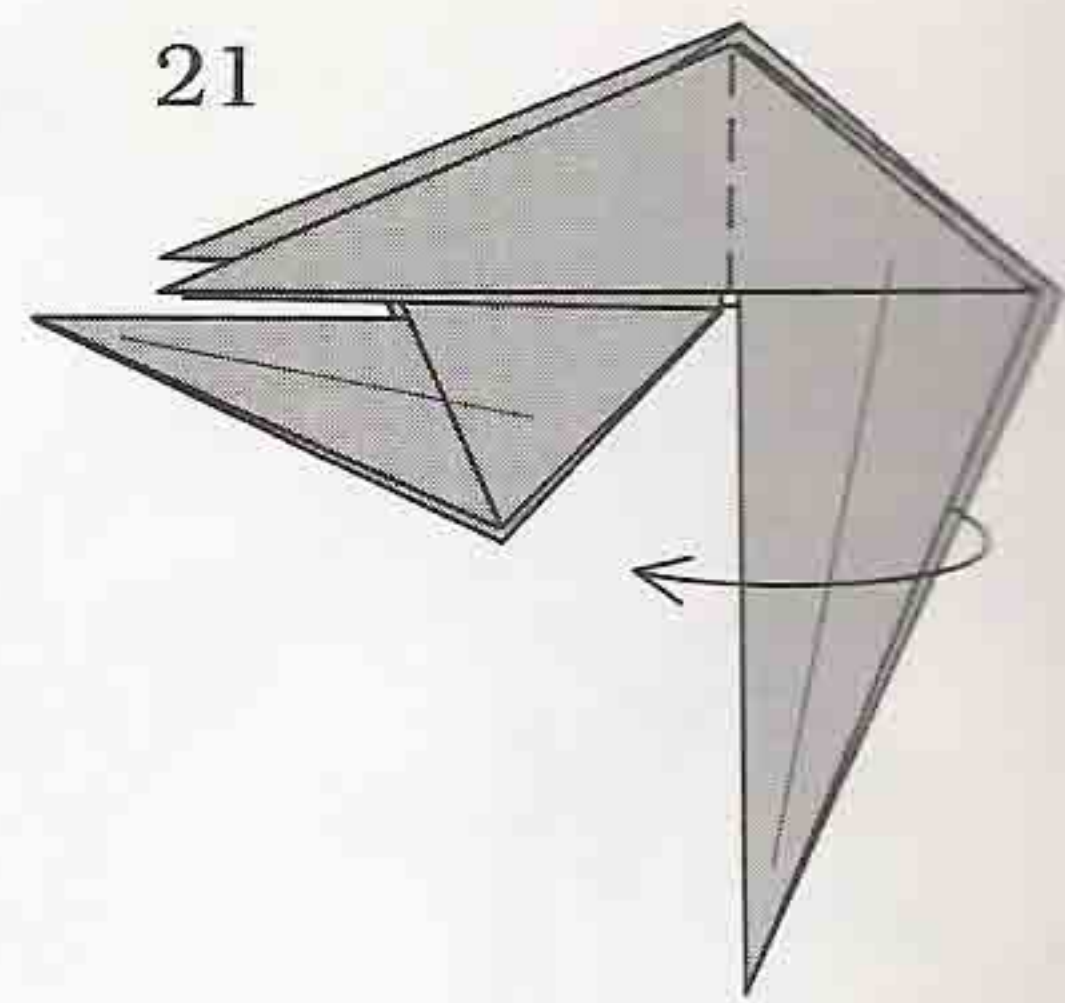

22

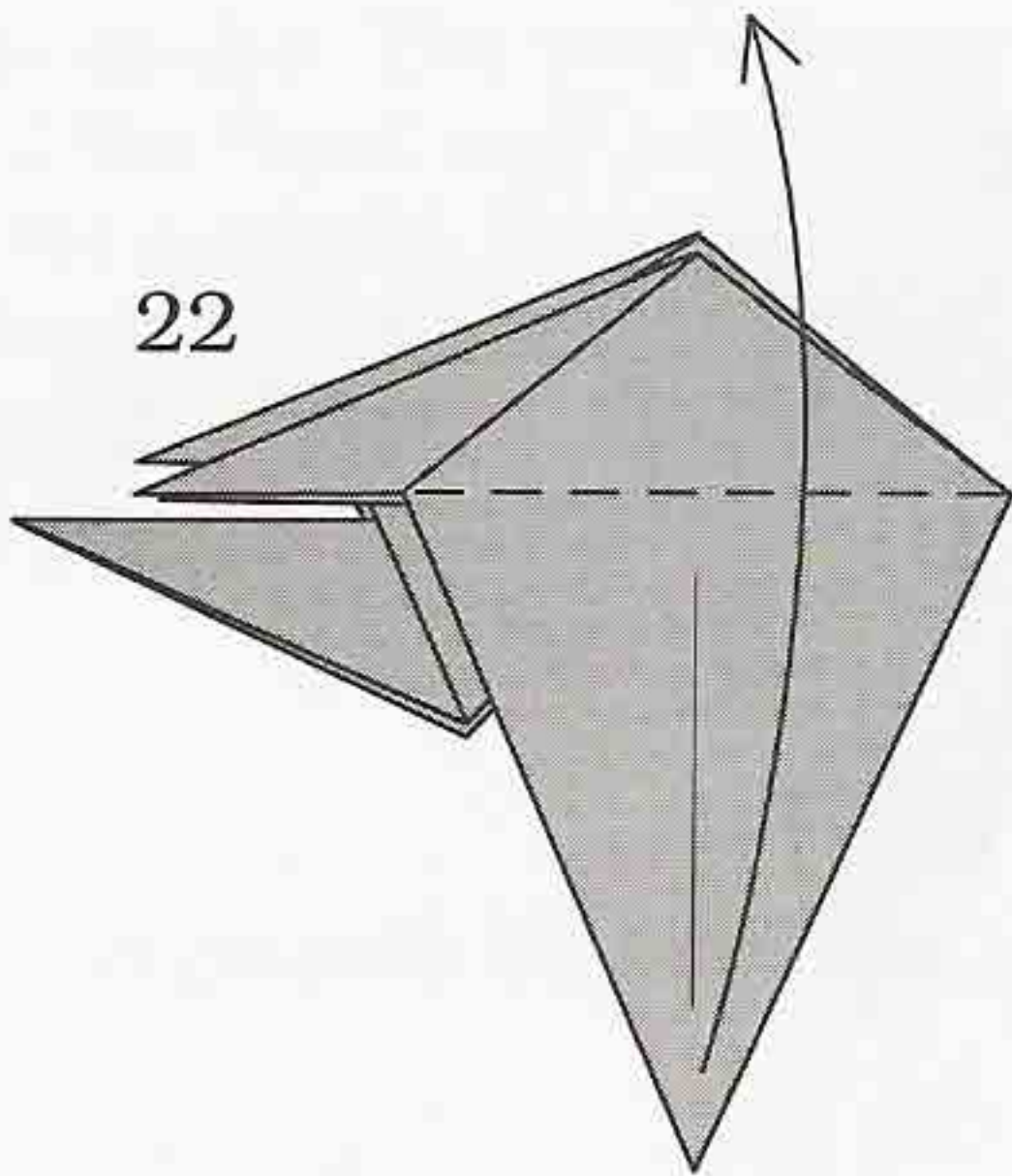

23

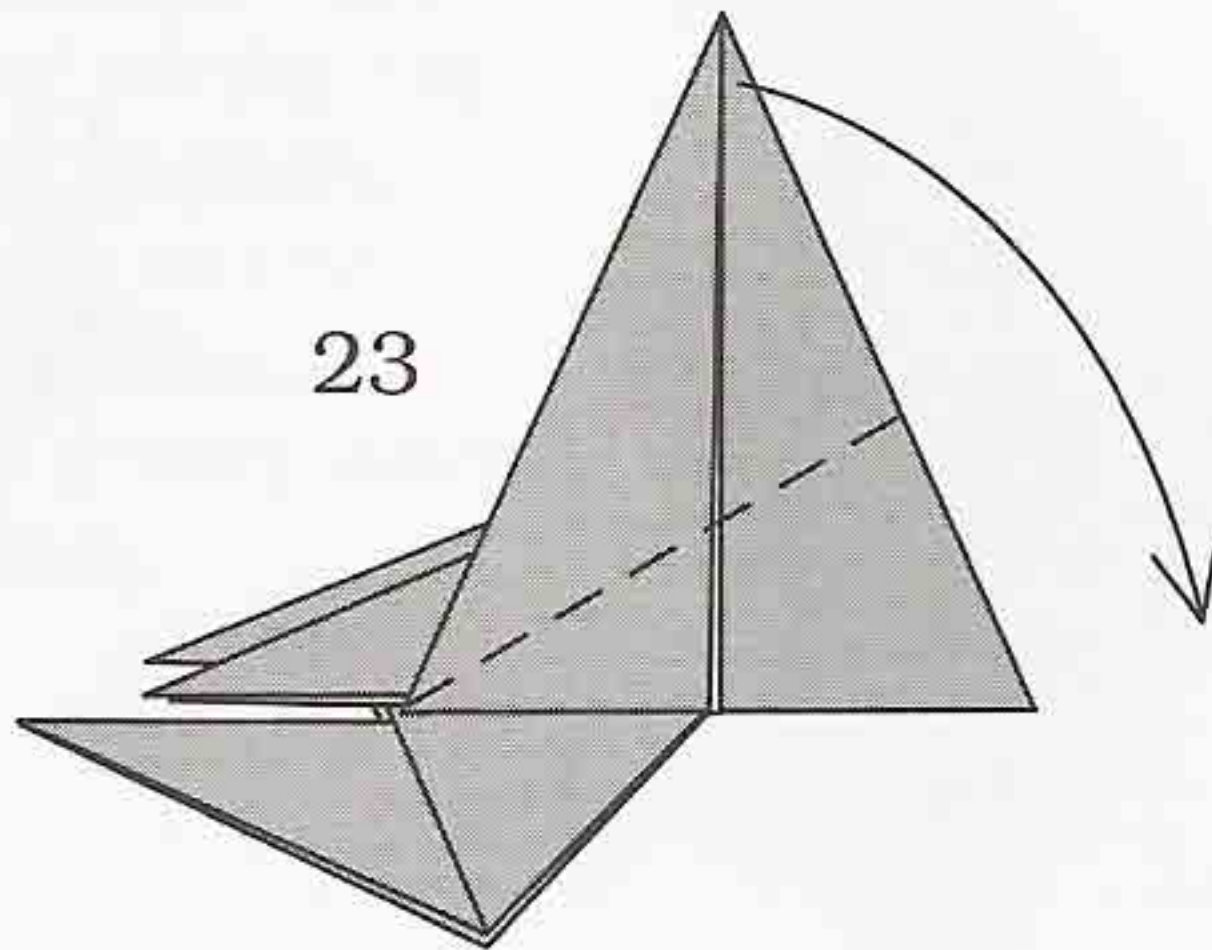

24

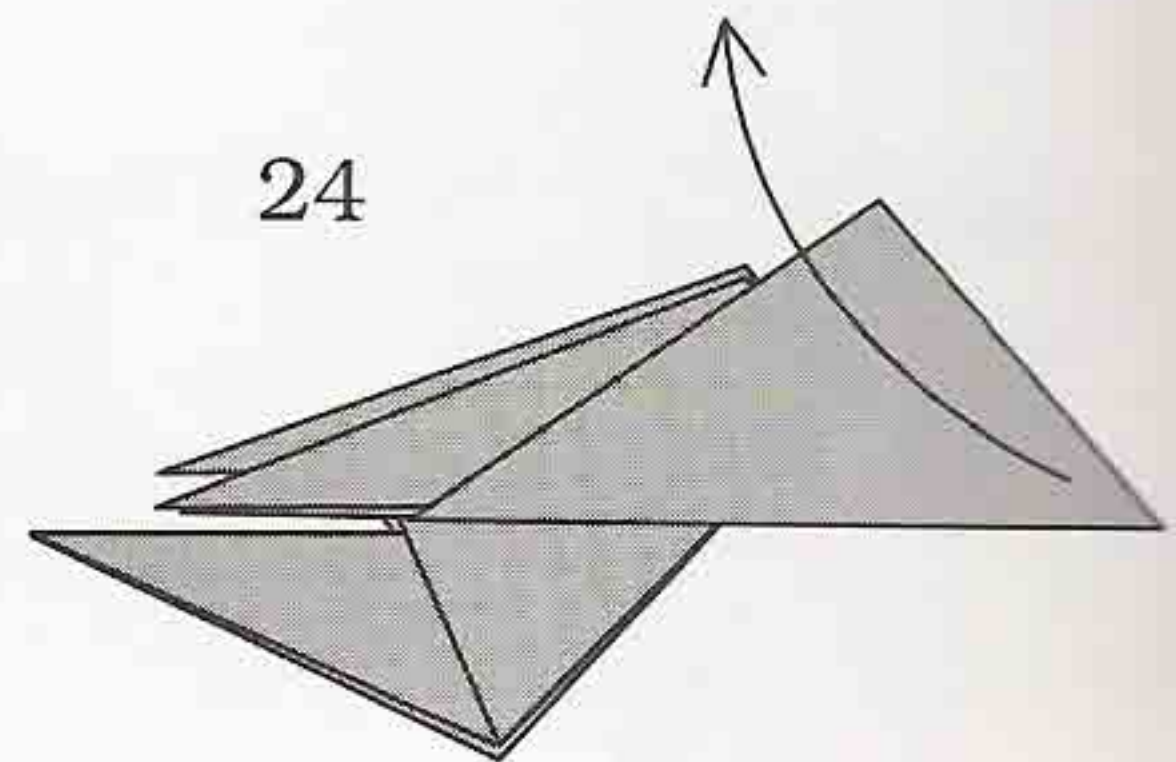

Unfold.

25

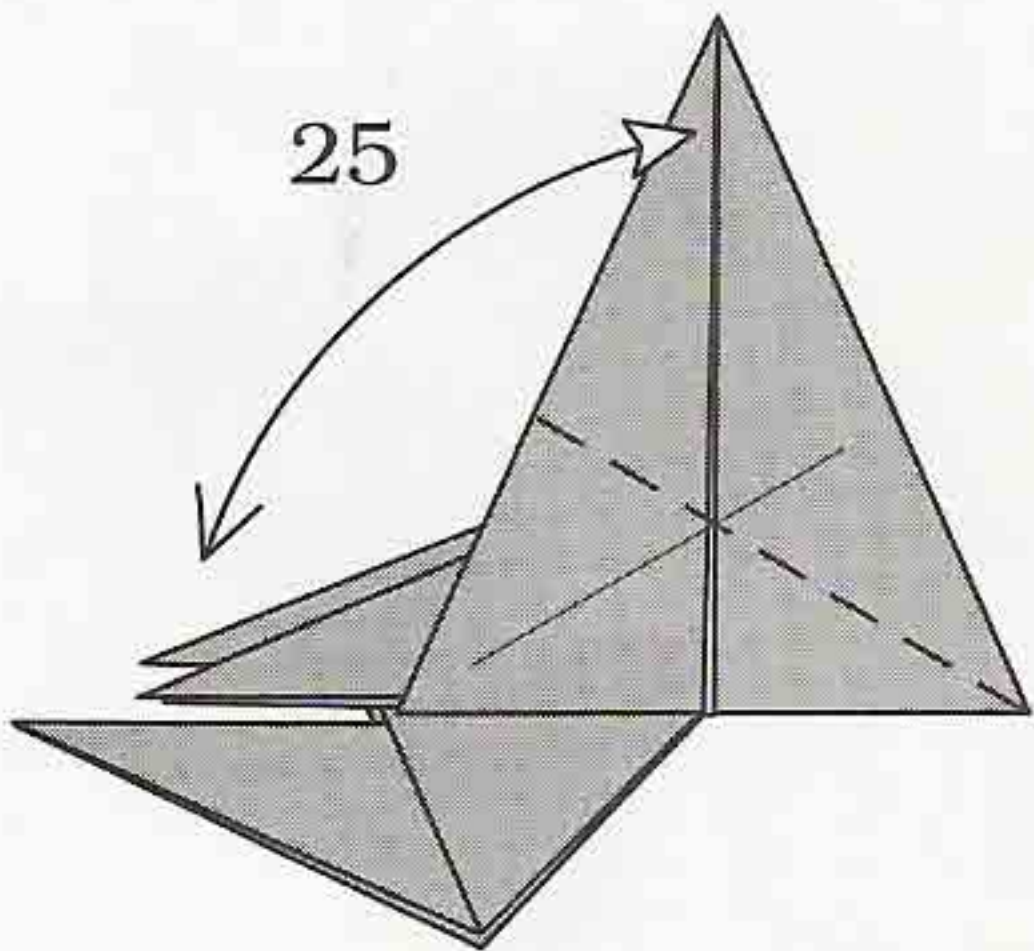

Fold to the left and unfold.

26

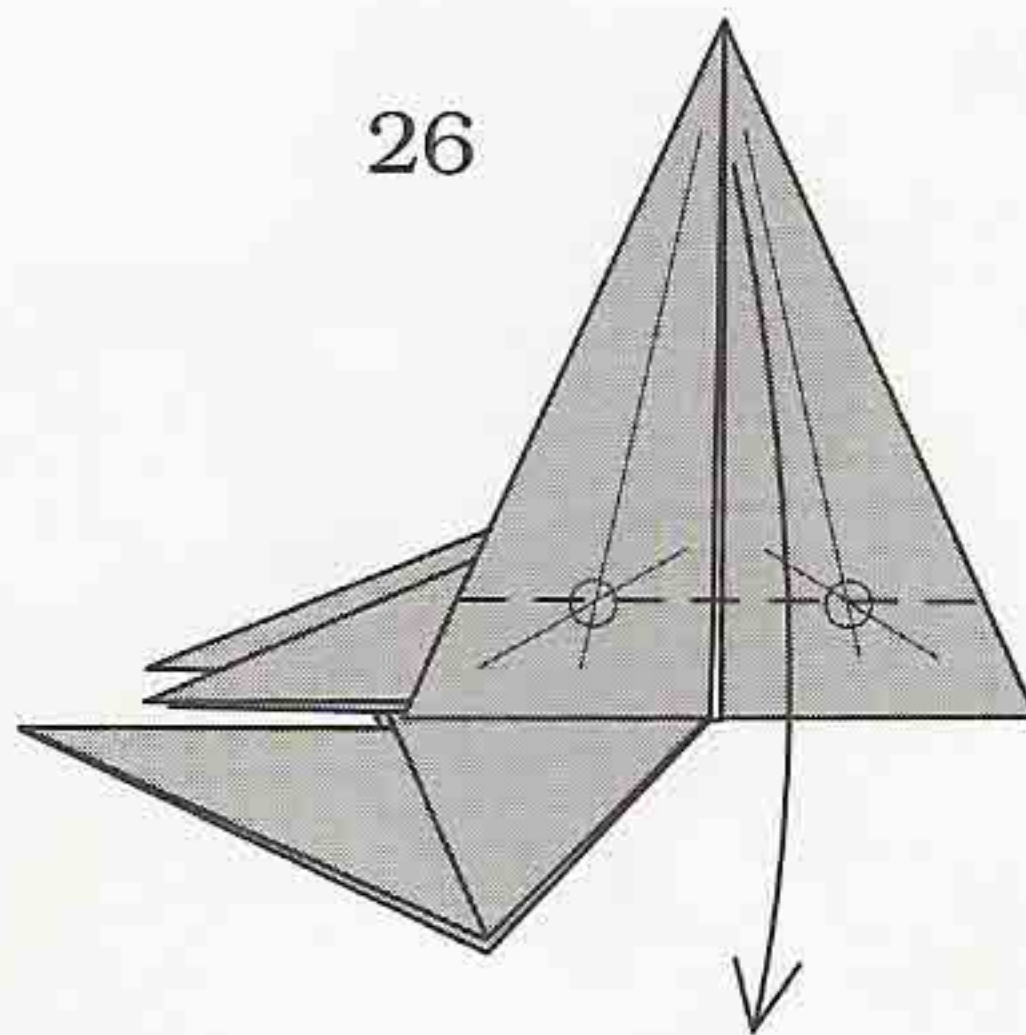

Fold down at the intersection of the lines.

27

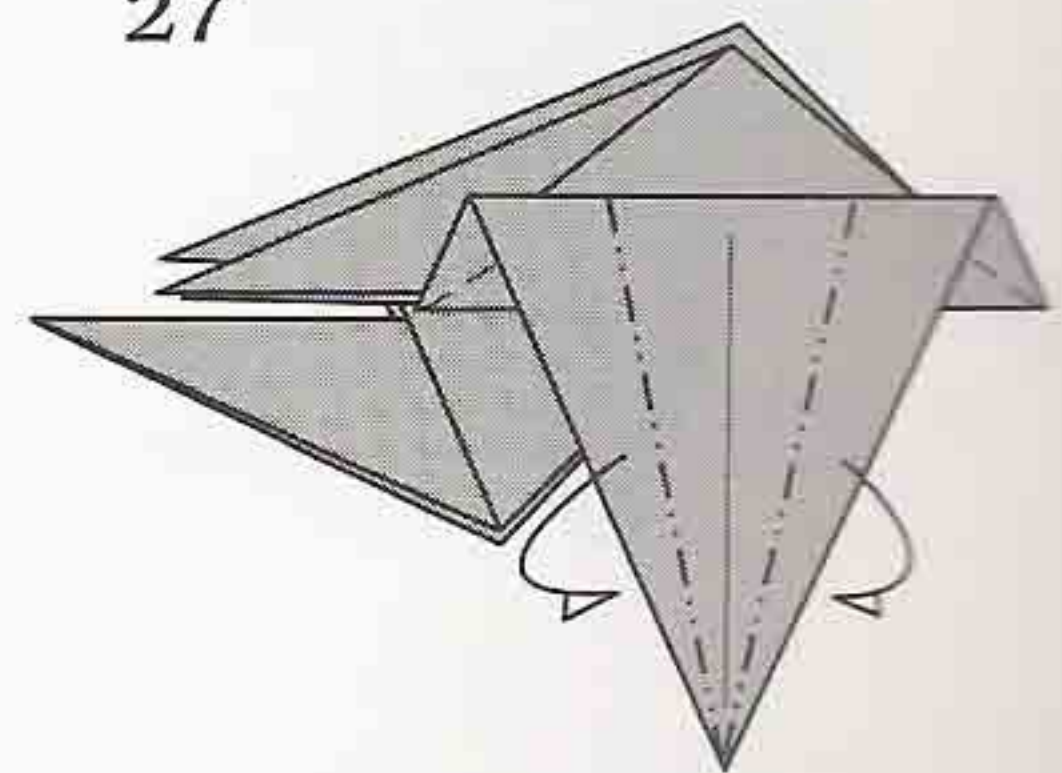

28

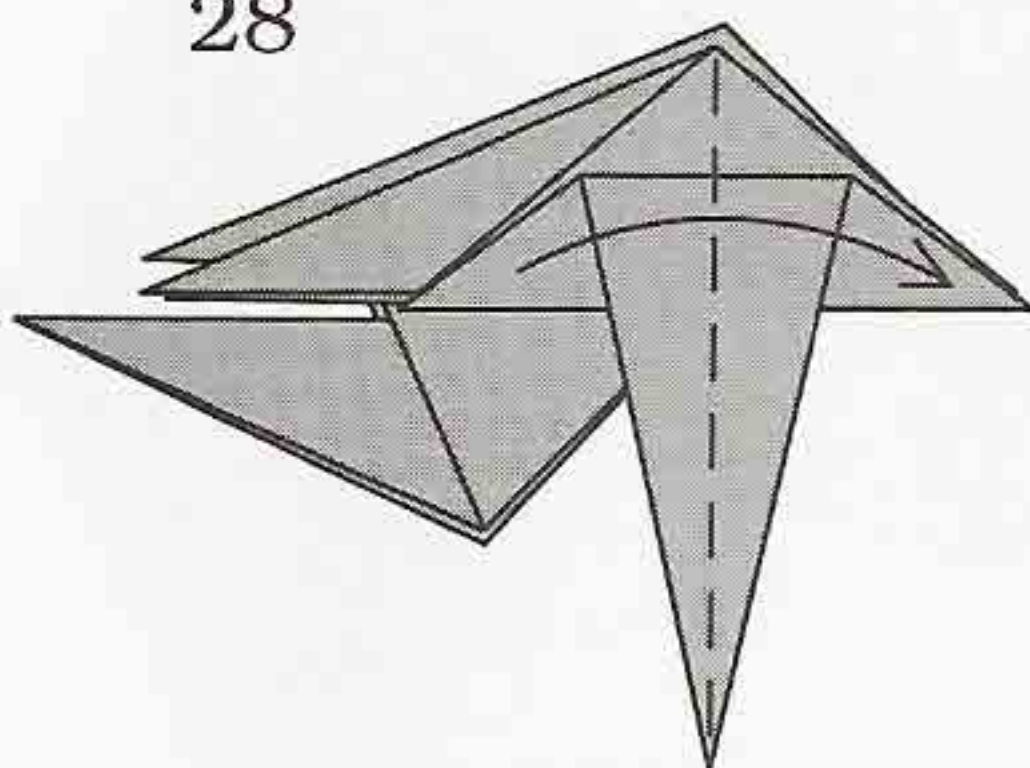

29

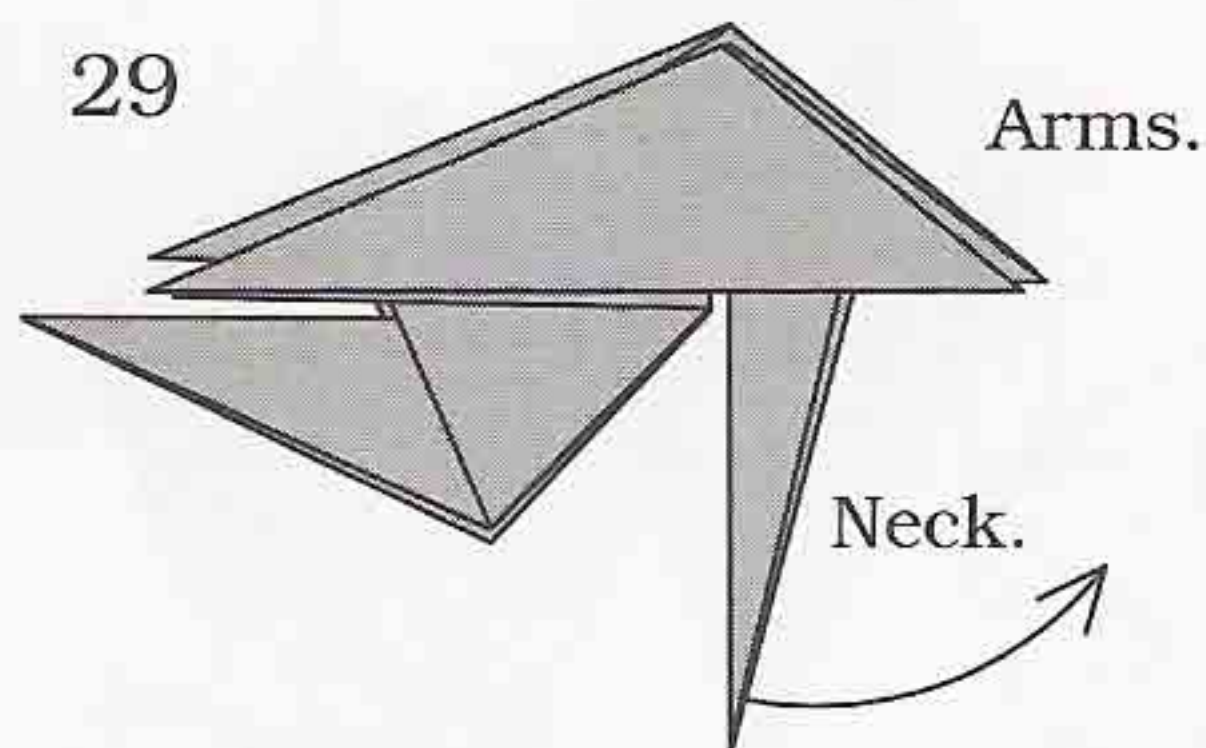

Slide the neck up but do not disturb the folds in the arms.

30

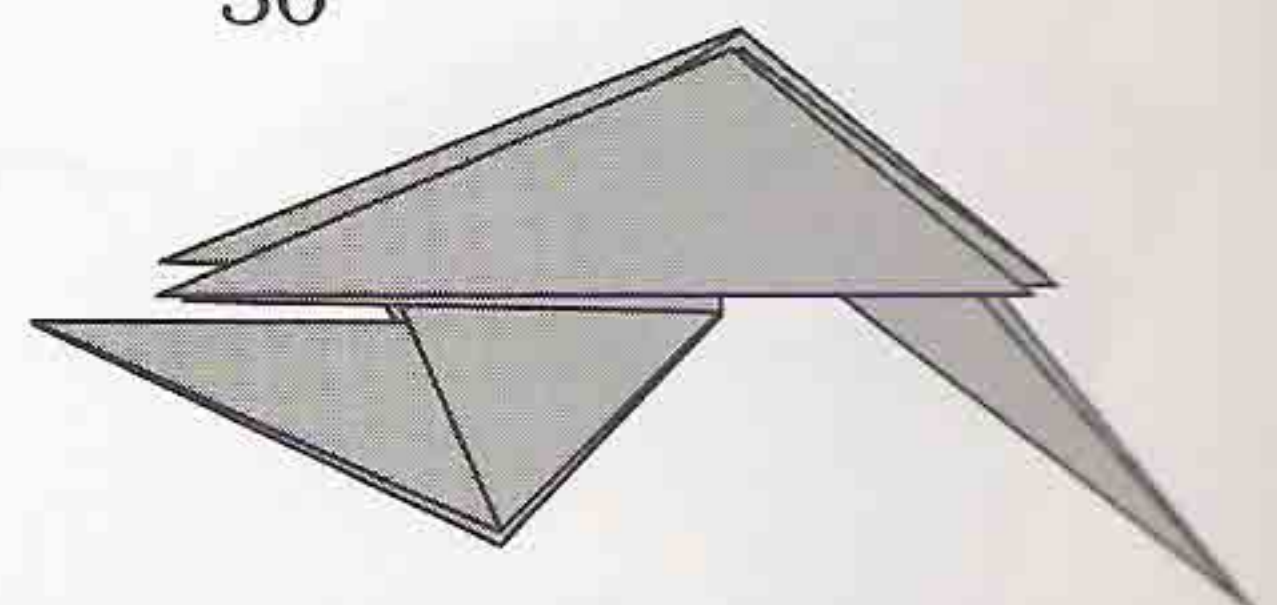

Rotate the model.

31

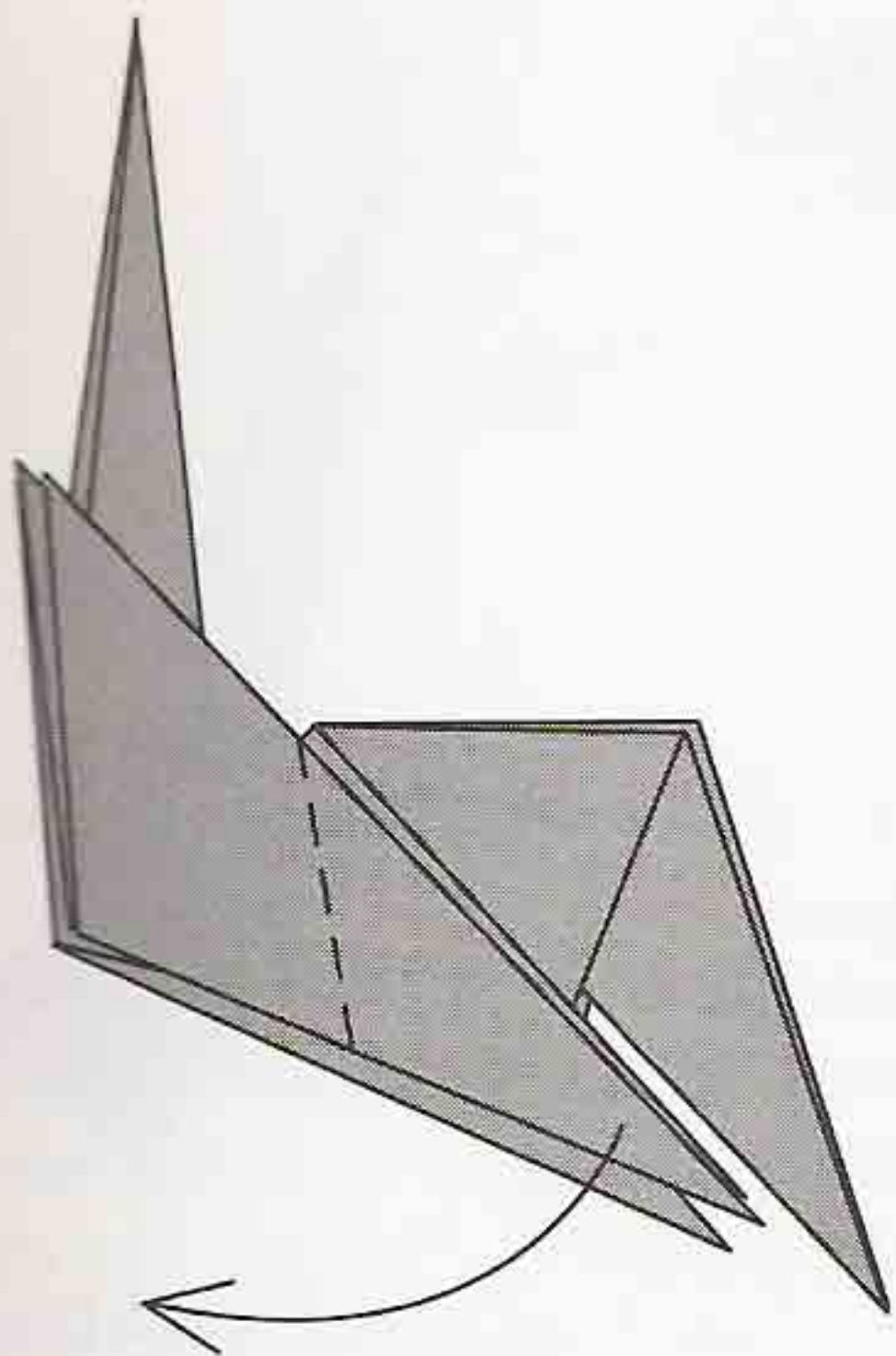

Repeat behind.

32

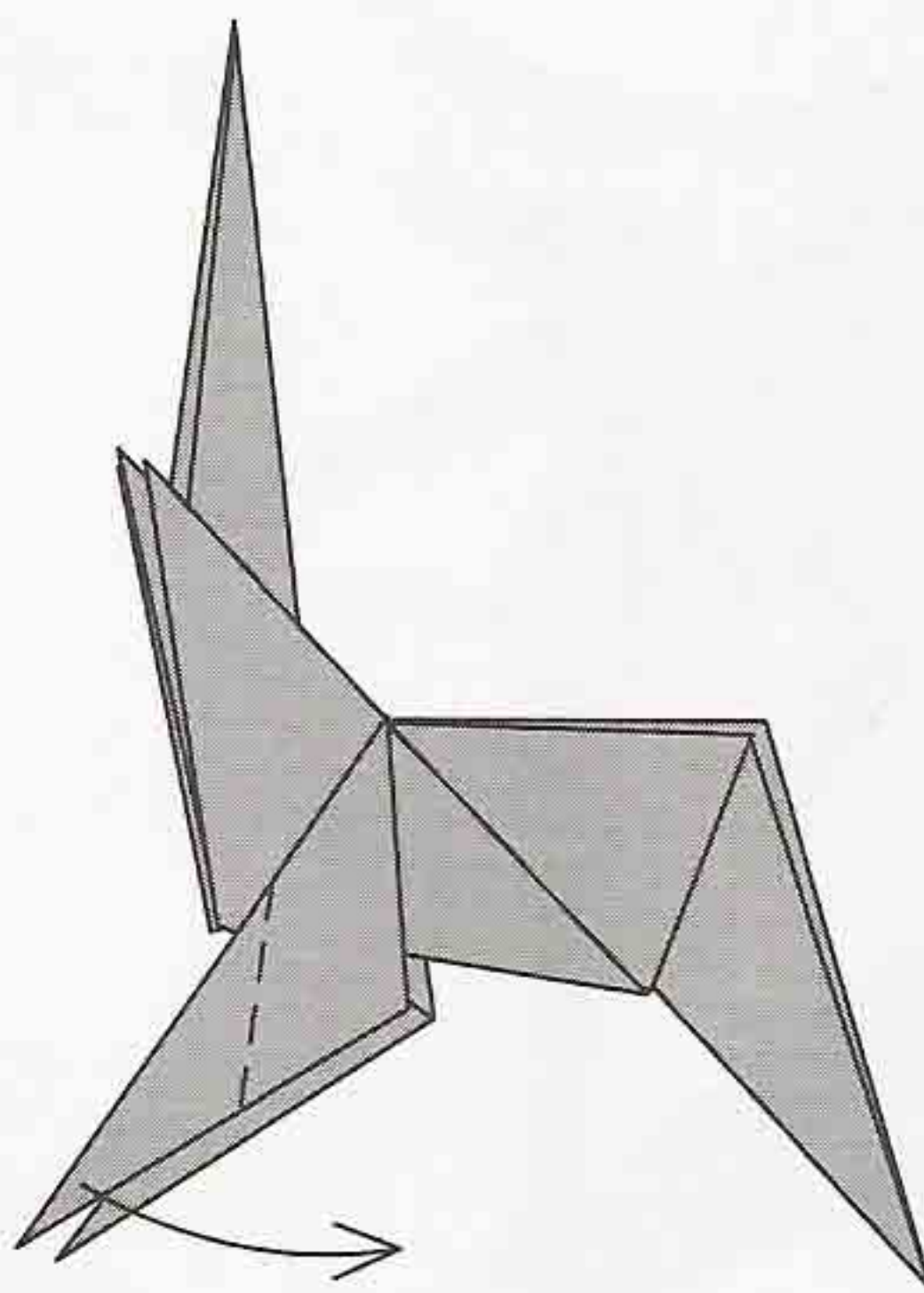

Repeat behind.

33

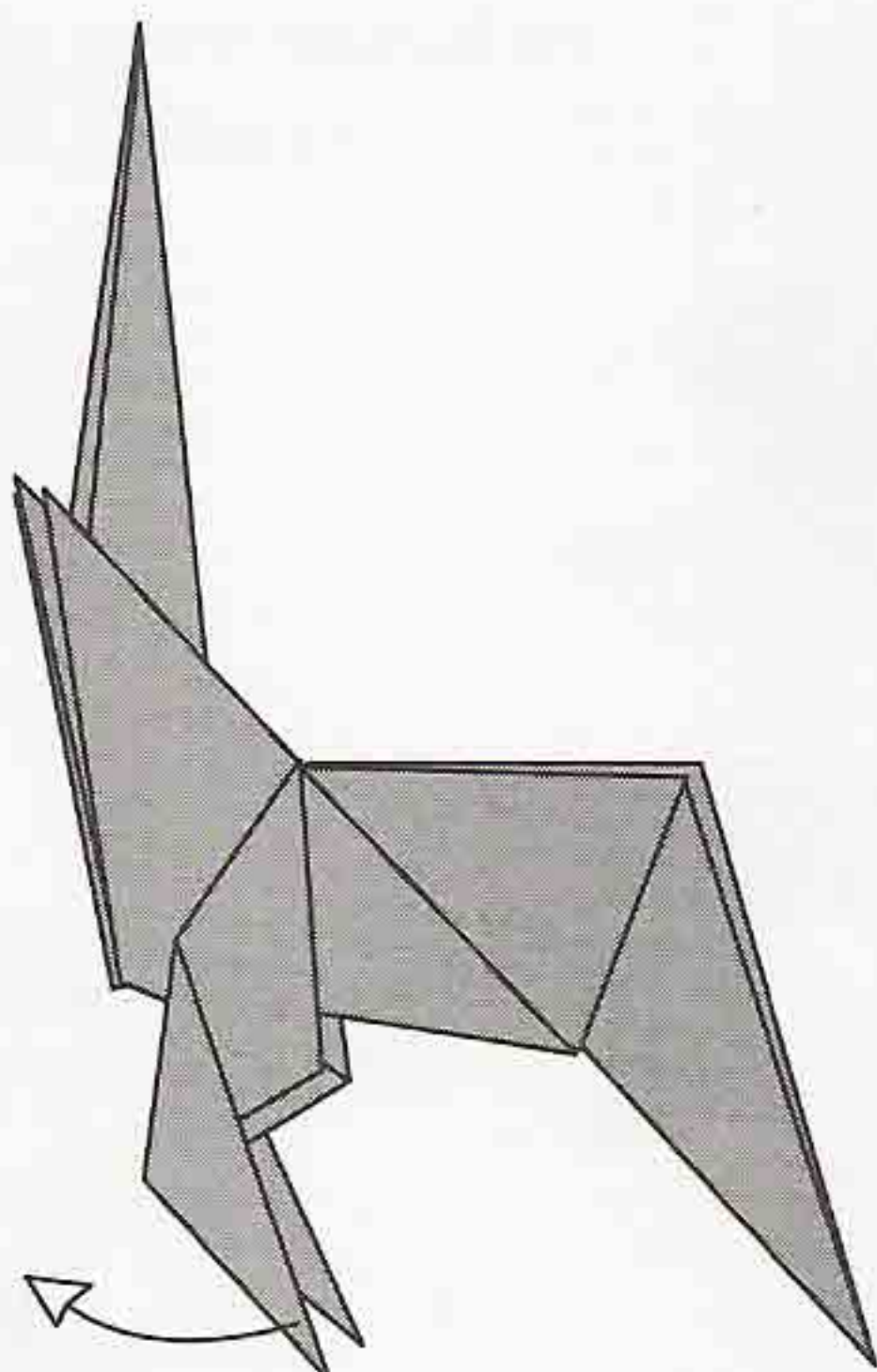

Unfold, repeat behind.

34

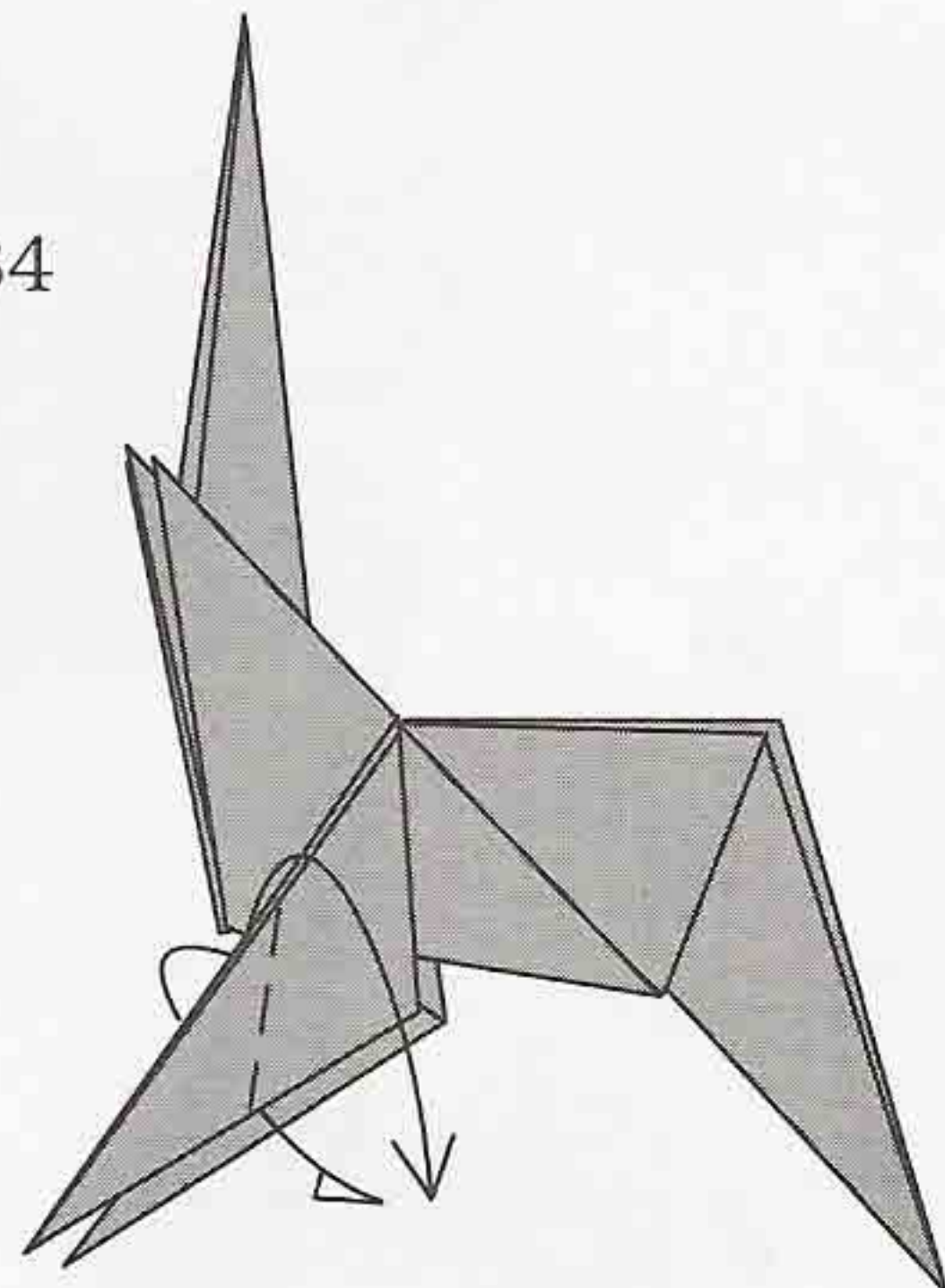

Outside-reverse-fold, repeat behind.

35

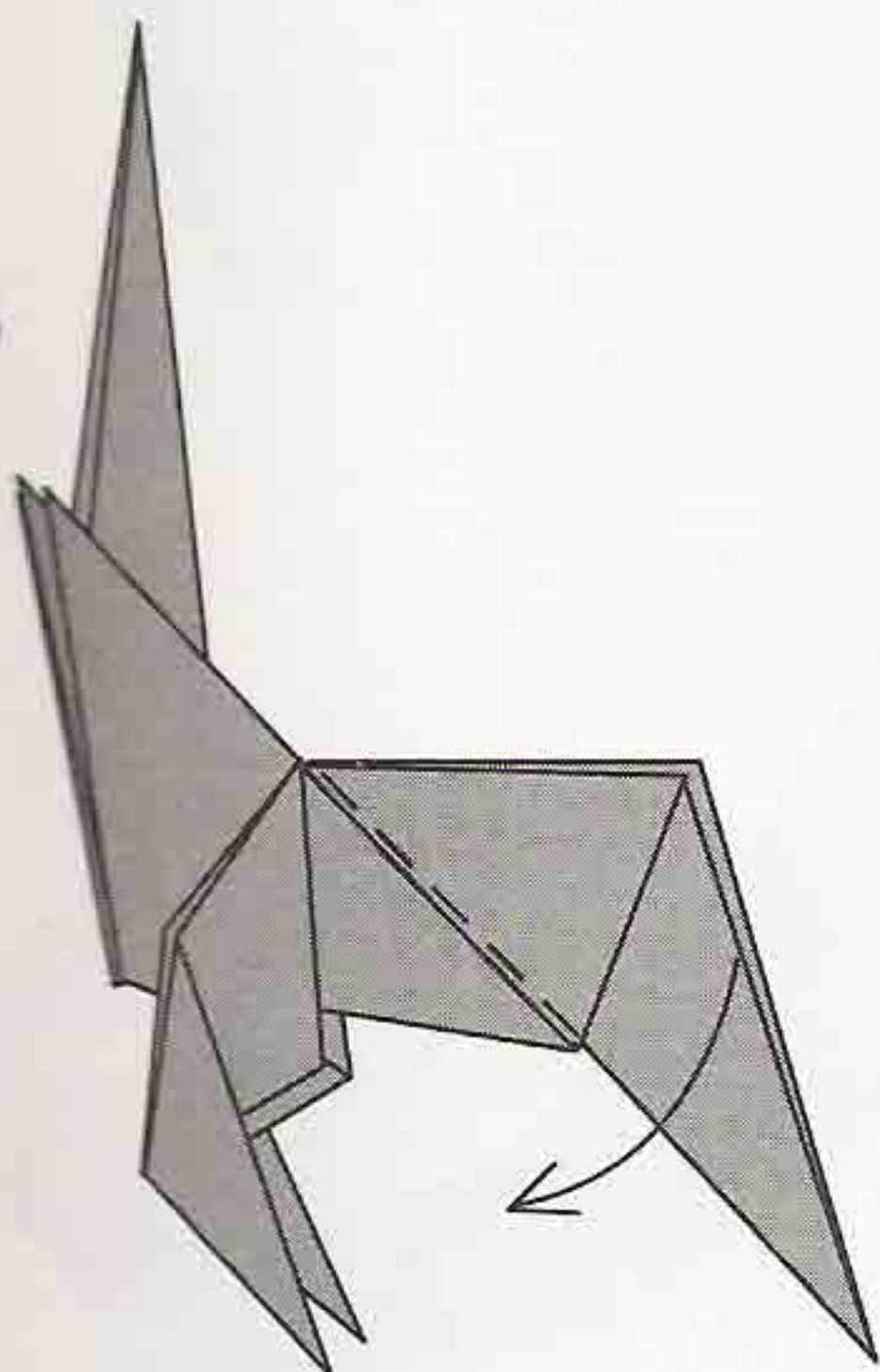

Repeat behind.

36

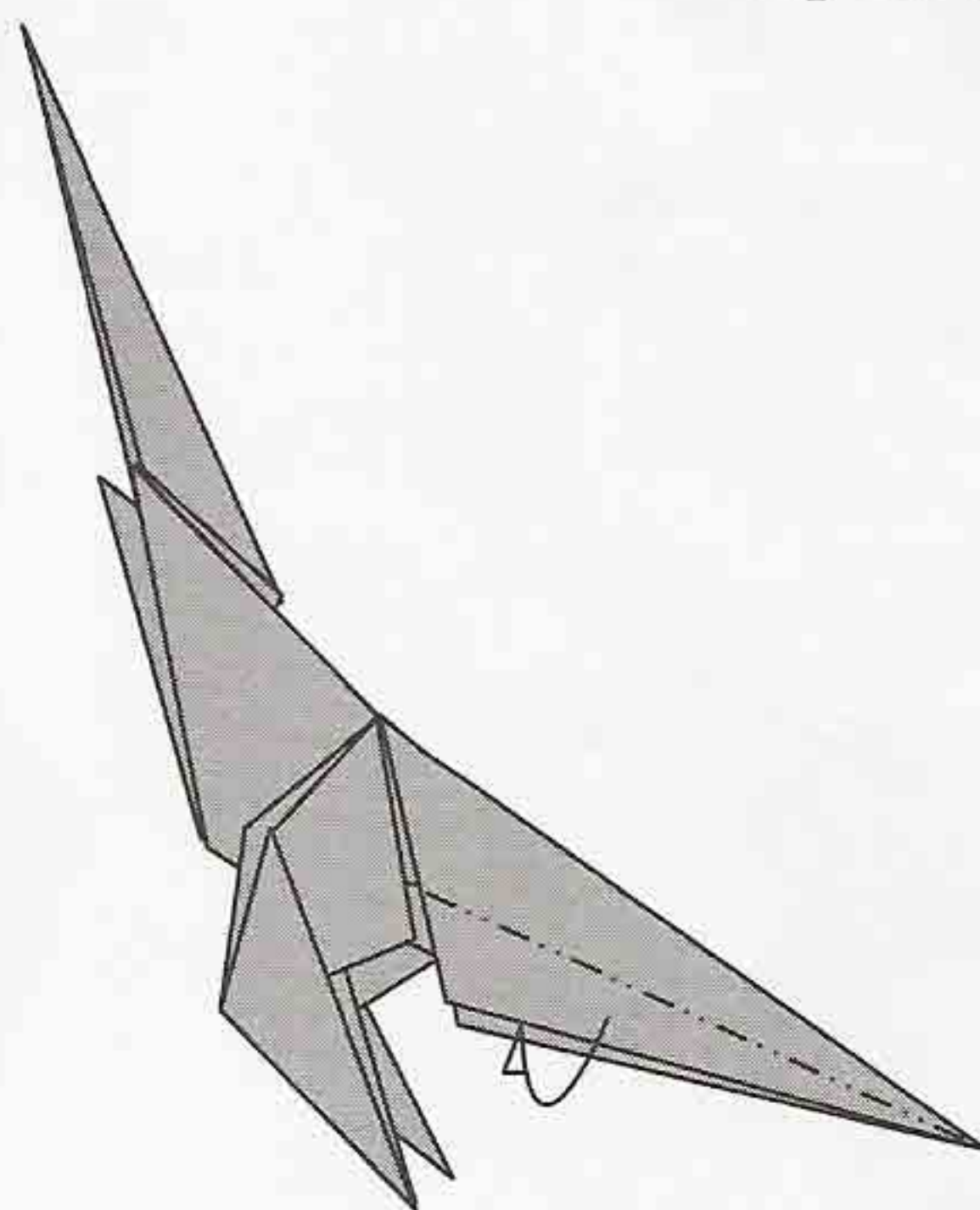

Tuck this paper inside the most central layer near the top of the tail. Repeat behind.

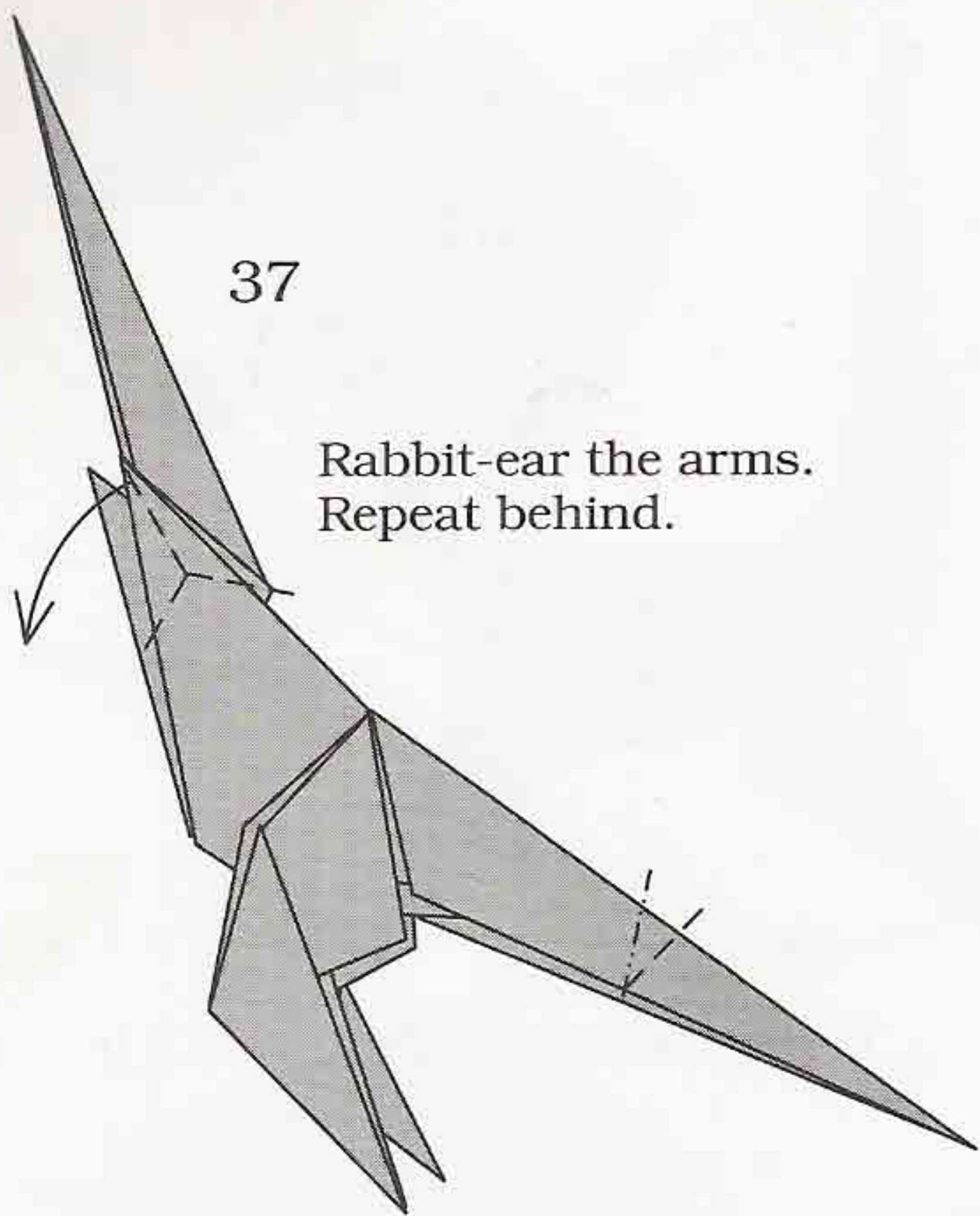

37

Rabbit-ear the arms.
Repeat behind.

Crimp-fold the tail.

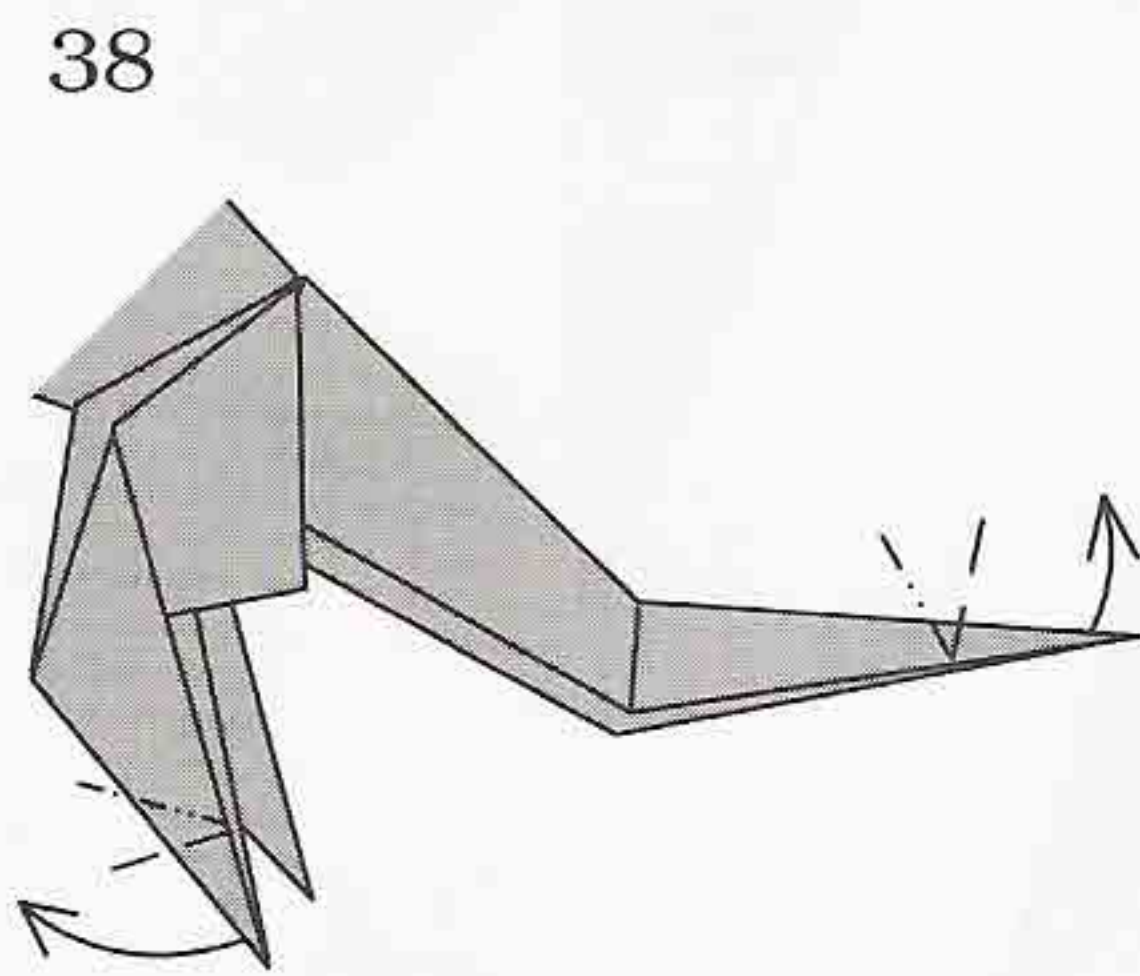

38

Crimp-fold the feet and
tail, repeat behind.

39

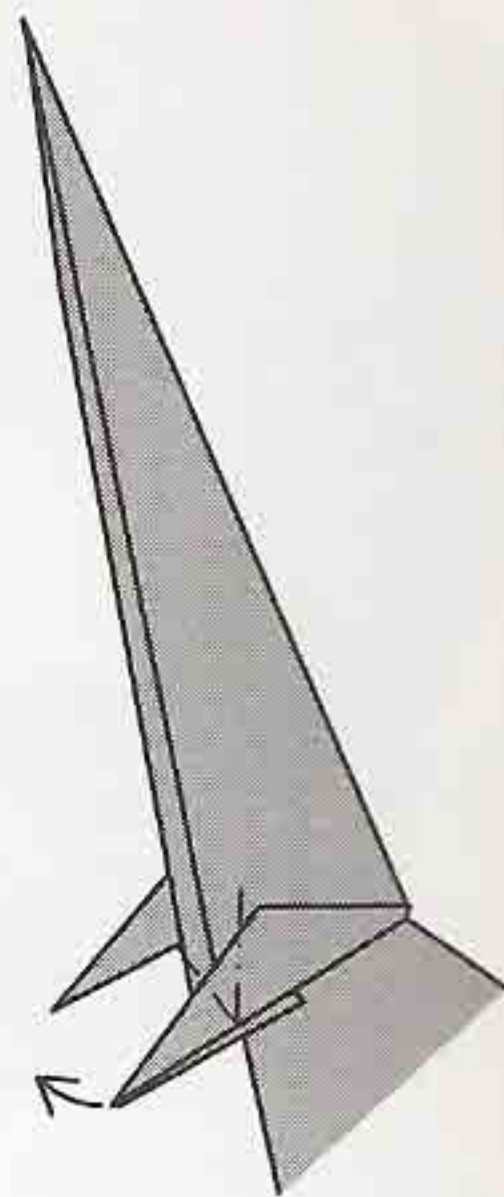

Crimp-fold the arms,
repeat behind.

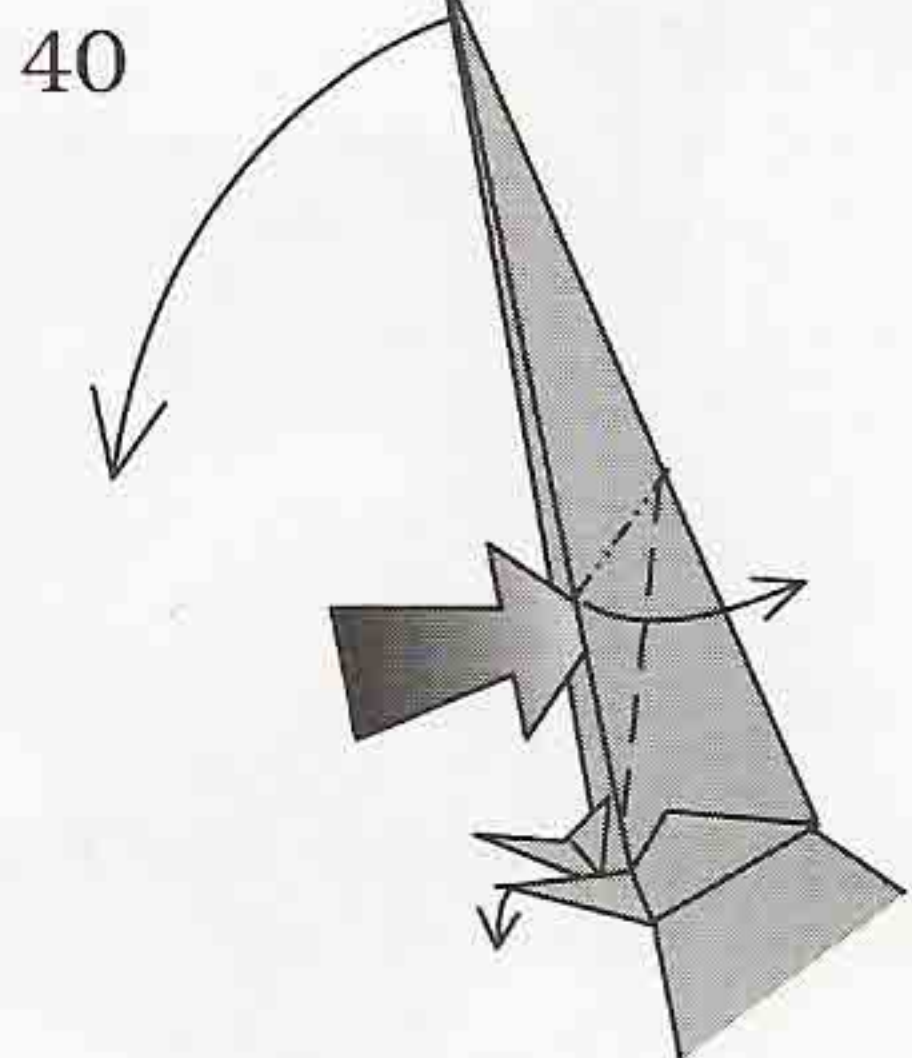

40

Crimp-fold the neck.
Fold the hands down,
repeat behind.

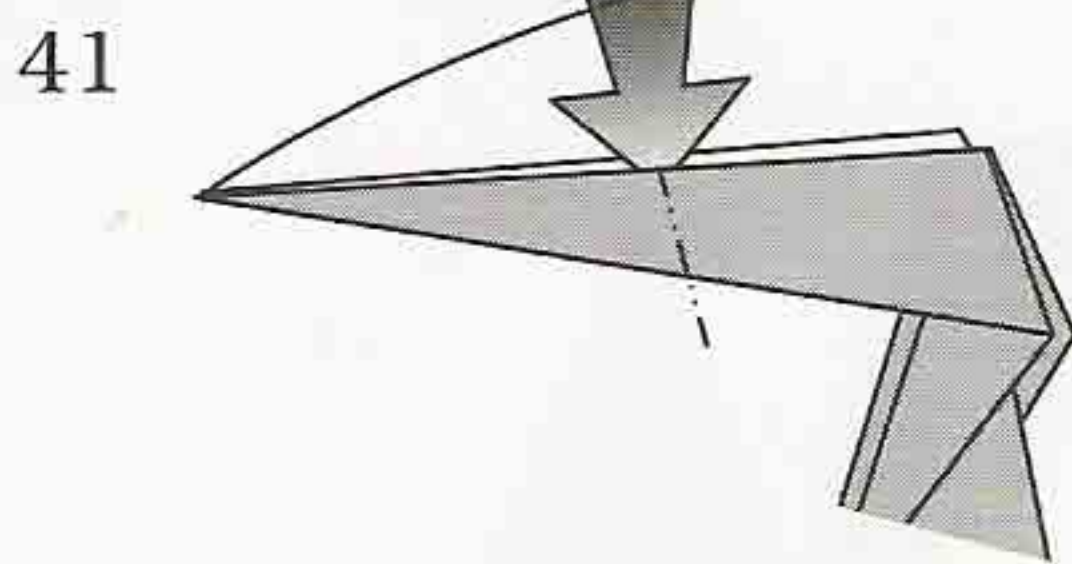

41

This asymmetric reverse fold
will form the white crown.

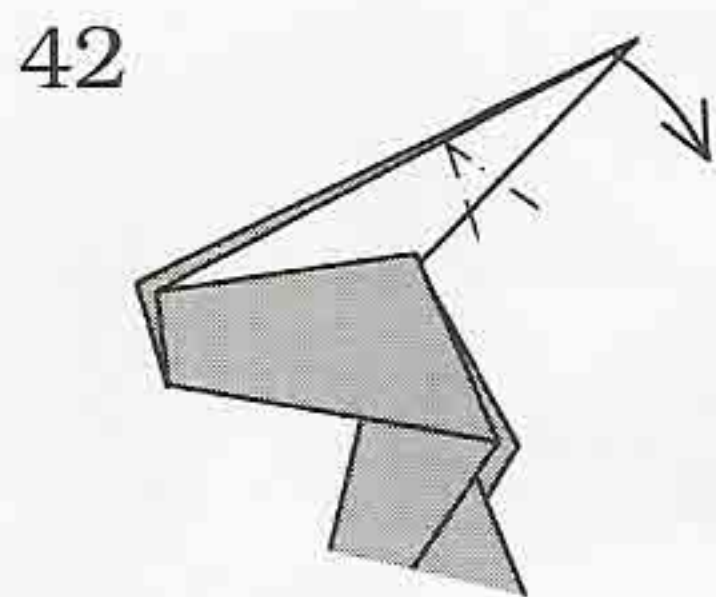

42

Crimp-fold the crown.

43

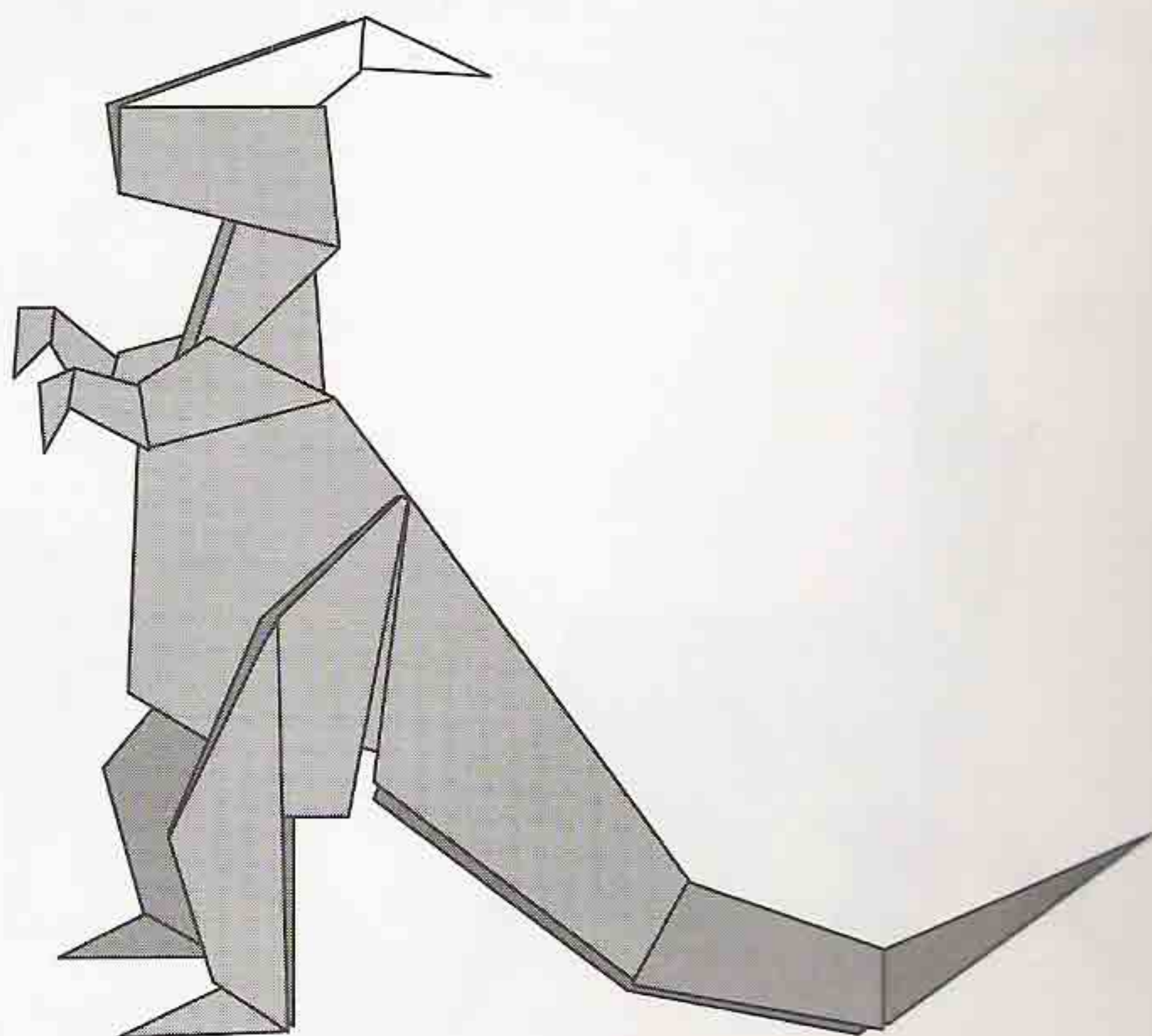

Parasaurolophus